

Lift Check Valve

BOA-R

Type Series Booklet



Legal information/Copyright

Type Series Booklet BOA-R

All rights reserved. The contents provided herein must neither be distributed, copied, reproduced, edited or processed for any other purpose, nor otherwise transmitted, published or made available to a third party without the manufacturer's express written consent.

Subject to technical modification without prior notice.

© KSB SE & Co. KGaA, Frankenthal 29/07/2019

Contents

Check Valves and Strainers	4
Lift Check Valves to DIN/EN	4
BOA-R.....	4
Main applications.....	4
Fluids handled	4
Operating data.....	4
Valve body materials.....	4
Design details	4
Product benefits.....	4
Product information	4
Certifications	5
Related documents	5
Purchase order specifications	5
Pressure/temperature ratings.....	5
Materials.....	6
Flow characteristics	7
Dimensions and weights.....	10
Installation information.....	11
Chemical resistance chart	12

Check Valves and Strainers

Lift Check Valves to DIN/EN

BOA-R



Main applications

- Hot-water heating systems
- Boiler feed applications
- Chemical industry
- Process engineering
- Heat recovery systems
- Sugar industry

Fluids handled

- High-temperature hot water
- Saturated steam
- Thermal oil
- Liquids and gases not chemically or mechanically aggressive to the valve materials.
- Other fluids on request.

Operating data

Operating properties

Characteristic	Value	
	EN-GJL-250	EN-GJS-400-18-LT
Nominal pressure	PN 6/16	PN 16
Nominal size	DN 15 - 300	DN 15 - 350
Max. permissible pressure [bar]	16	16
Min. permissible temperature [°C]	≥ -10	≥ -10
Max. permissible temperature [°C]	≤ +300	≤ +350

Selection as per pressure/temperature ratings (⇒ Page 5)

Valve body materials

Overview of materials available for straight-way valve

Material	Material number	Temperature limit
EN-GJL-250	5.1301	≤ 300 °C
EN-GJS-400-18-LT	5.3103	≤ 350 °C

Overview of materials available for angle valve

Material	Material number	Temperature limit
EN-GJL-250	5.1301	≤ 300 °C

Design details

Design

- Straight-way or angle pattern with horizontal seat
- Spring-loaded check disc
- Flanges to DIN EN 1092-2 Type 21
- Exterior coating: blue, RAL 5002

Variants

- Oil-free and grease-free: lubricated exclusively by mineral oil free lubricants approved by the German Federal Office for Materials Testing (Bundesanstalt für Materialforschung und -prüfung, BAM)
- Other flange designs
- High-temperature resistant paint (grey aluminium)
- Low-temperature steel bolts for temperatures down to -30 °C (EN-GJS-400-18-LT only) up to 0.75 x PN (max.)
- Certification to customer specification

Product benefits

- Check disc and closing springs made of stainless steel for high functional reliability and corrosion resistance
- Cover removable for inspection
- Versatile: Can be installed in vertical pipes with or without spring

Product information

Product information as per Regulation No. 1907/2006 (REACH)

For information as per chemicals Regulation (EC) No. 1907/2006 (REACH), see <http://www.ksb.com/reach>.

Product information as per Directive 2014/34/EU (ATEX)



The valves do not have a potential internal source of ignition and can be used in potentially explosive atmospheres, Group II, category 2 (zones 1+21) and category 3 (zones 2+22) to ATEX 2014/34/EU.

Product information as per Pressure Equipment Directive 2014/68/EU (PED)

The valves satisfy the safety requirements of Annex I of the European Pressure Equipment Directive 2014/68/EU (PED) for fluids in Groups 1 and 2.

Certifications

Overview

Label	Effective in:	Comment
	Worldwide	Approved for marine applications
	Worldwide	Approved for marine applications

Purchase order specifications

Please specify the following information in all enquiries or purchase orders:

1. Type
2. Nominal pressure
3. Nominal size
4. Material
5. Variants
6. Reference number

Related documents

Information/documents

Document	Reference number
Operating manual	0570.8
Typical tender for BOA-R JL PN 6	7117.521
Typical tender for BOA-R JL PN 16	7117.522
Typical tender for BOA-R JS PN 16	7117.523

Pressure/temperature ratings

Test pressure and operating pressure

PN	Material	Shell test	Leak test (seat)	Permissible operating pressure [bar] ¹⁾²⁾									
		With water to DIN EN 12266-1		[°C]									
		Tests P10 and P11 to DIN EN 12266-1	Test P12, leakage rate A to DIN EN 12266-1	-10 to +120	150	180	200	230	250	300	350		
		[bar]	[bar]										
6	EN-GJL-250	9	6,6	6	5,4	5	4,8	4,4	4,2	3,6	-		
16	EN-GJL-250	24	17,6	16	14,4	13,4	12,8	11,8	11,2	9,6	-		
16	EN-GJS-400-18-LT	24	17,6	16	15,5	-	14,7	-	13,9	12,8	11,2		

1) Intermediate temperatures can be derived by linear interpolation.
2) Static load

Materials

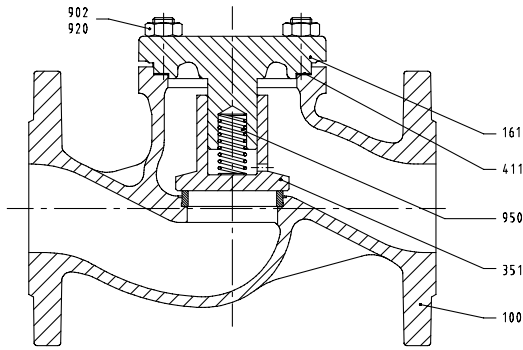

Fig. 1: BOA-R

Parts list

Part No.	Description	PN	DN	Material	Material number
100	Body ³⁾⁴⁾	6/16	15 - 300	EN-GJL-250	5.1301
		16	15 - 300	EN-GJS-400-18-LT	5.3103
161	Body cover ⁴⁾	6/16	15 - 300	EN-GJL-250	5.1301
		16	15 - 300	EN-GJS-400-18-LT	5.3103
351	Check disc ⁴⁾	6	15 - 150	X 20 CR 13	1.4021
		16	15 - 150		
		6	200	St, sealing surface C22/ X 15 CrNi 18 8	1.0402/1.4370
		16	200 - 350	Guide pin X 20 Cr 13	1.4021
411	Joint ring ⁴⁾	-	-	CrNi steel/graphite	-
515	Seat ring	-	-	Stainless steel	-
902	Stud ⁴⁾	-	-	C 35 E	-
920	Hexagon nut ⁴⁾	-	-	C 35	-
950	Spring ⁴⁾	-	-	X 12 CrNi 17 7	1.4310

3) Body marked "BOA-H"
4) Spare part

Flow characteristics

DN 15 to 50

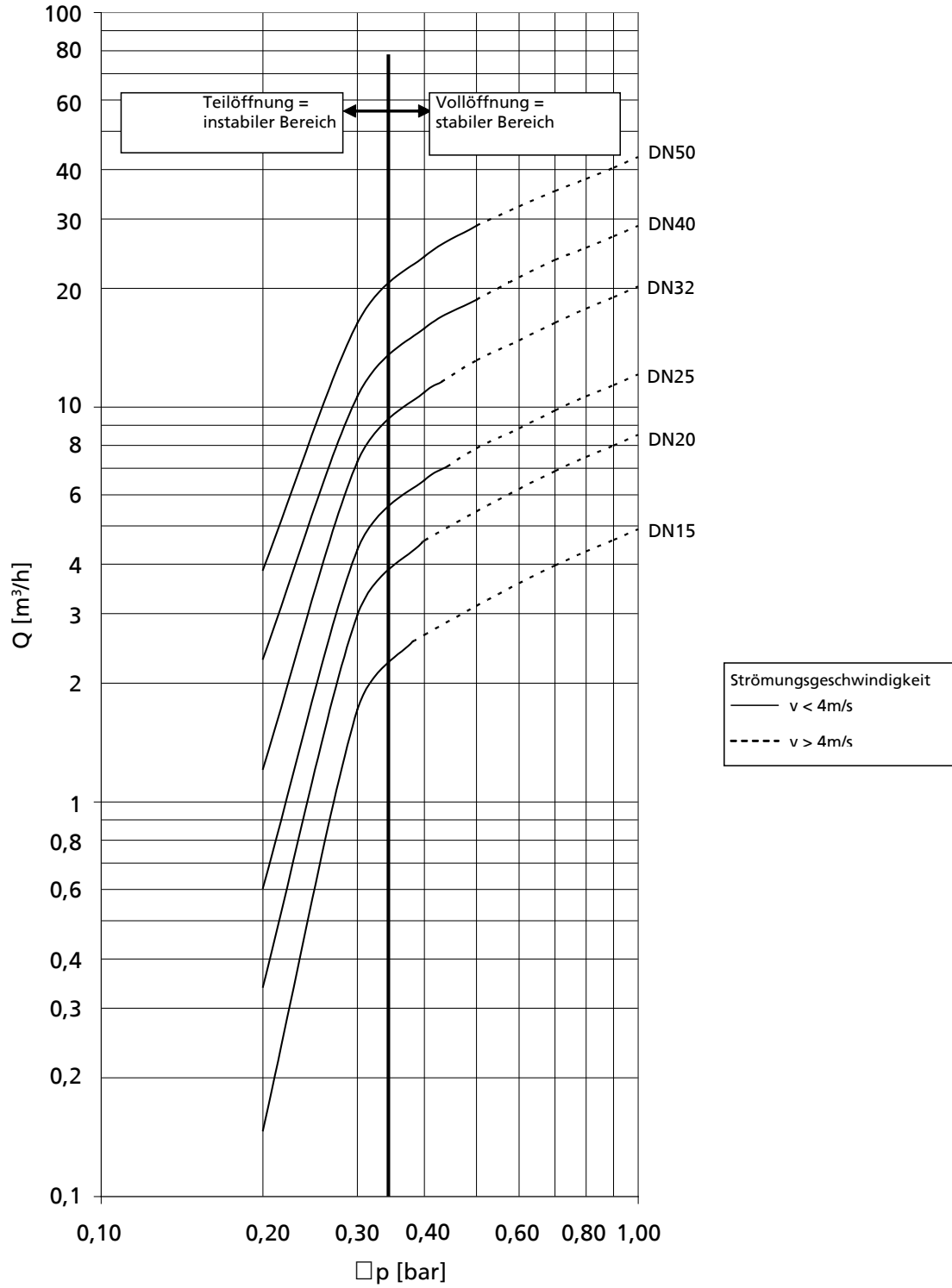

DN 65 to 200

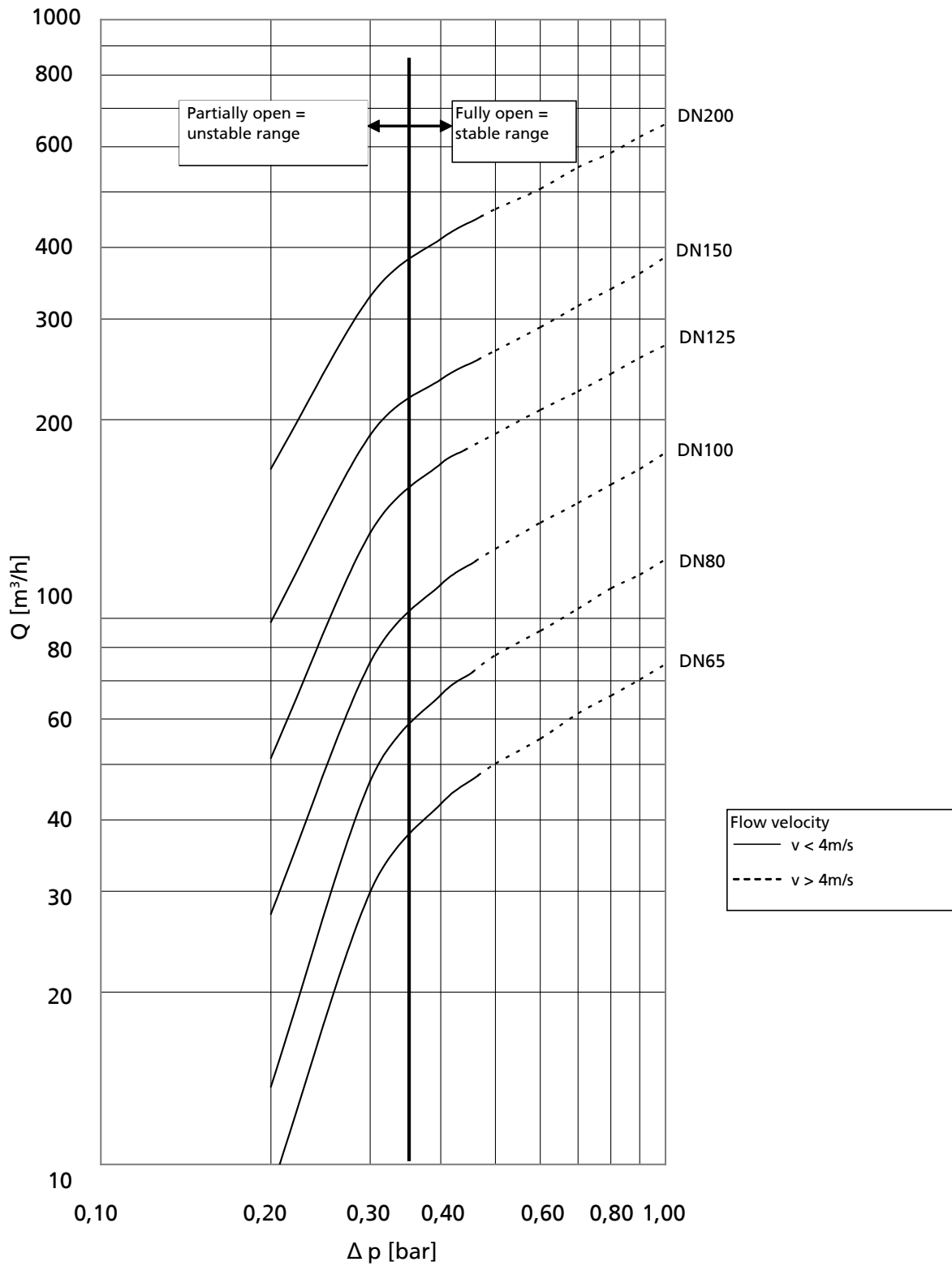

DN 250 to 350

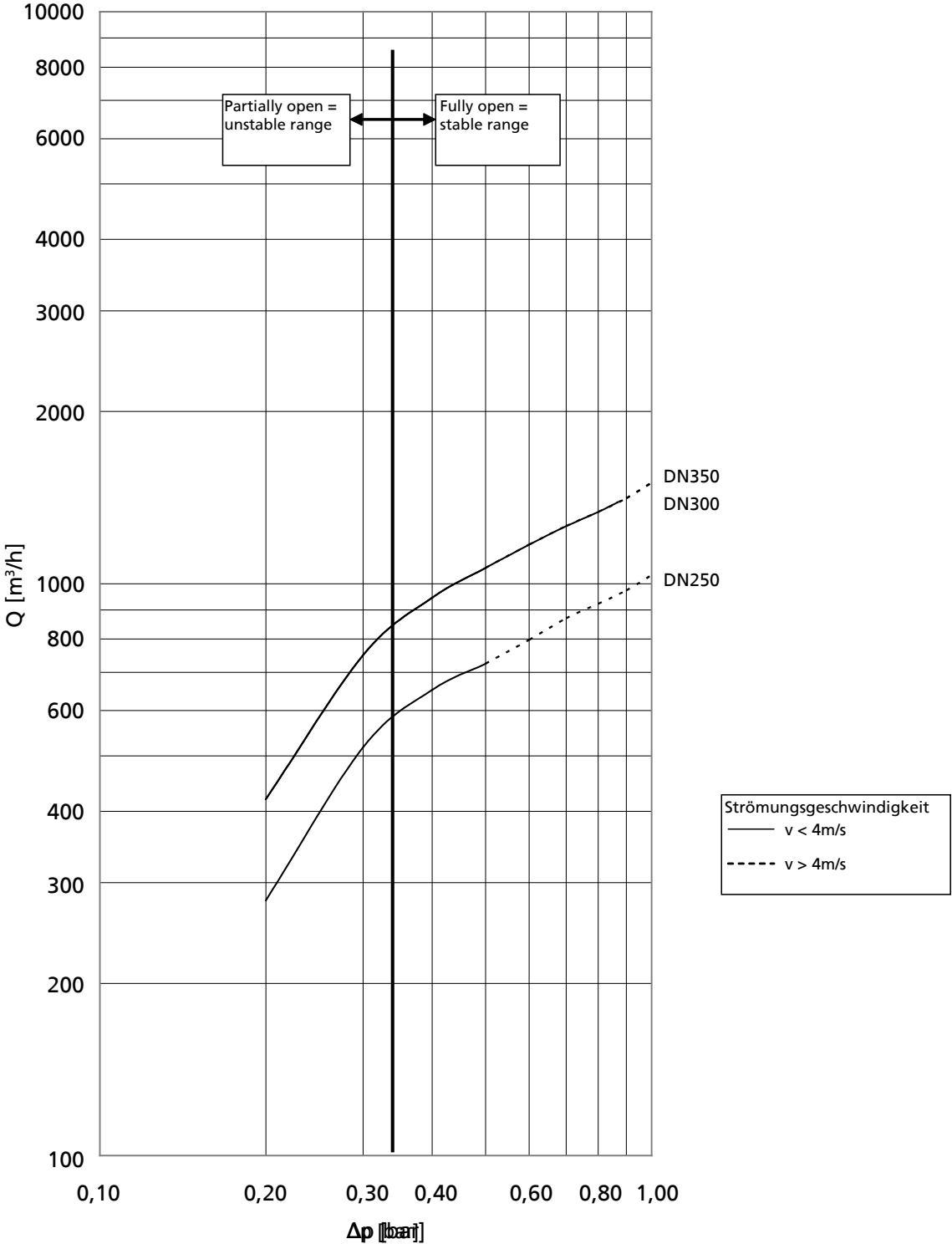

7117.1/24-EN

Dimensions and weights

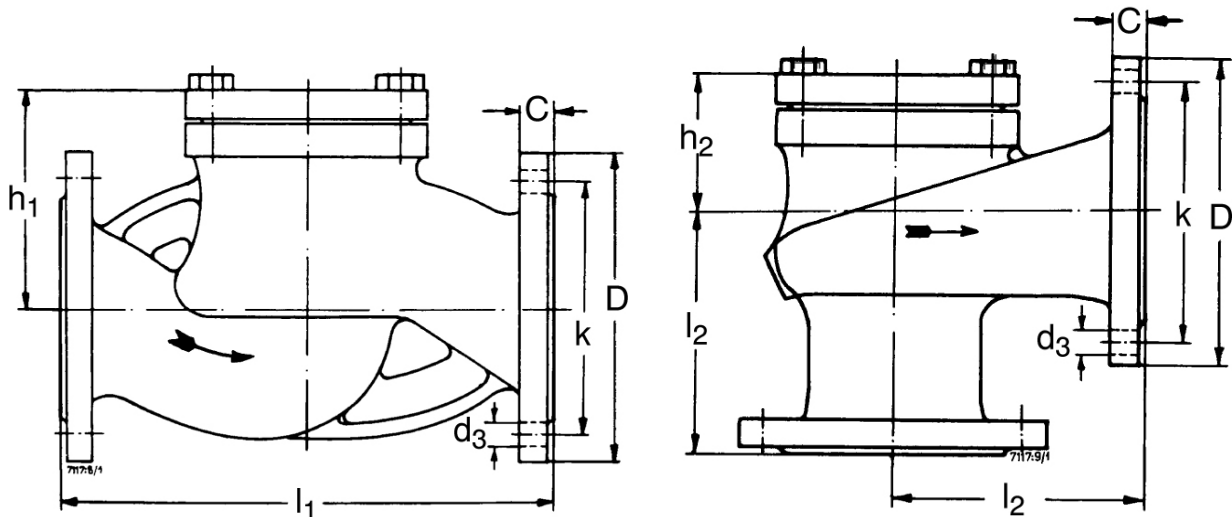

Straight-way
valve

Angle
valve

Dimensions and weights

PN	DN	C	D	h ₁	h ₂	Ø k	l ₁	l ₂	n x d ₃	Straight-way valve	Angle valve
		[mm]	[mm]	[mm]	[mm]	[mm]	[mm]	[mm]	[mm]	[kg]	[kg]
6 ⁵⁾	15	14	95	50	-	55	130	-	4 x 11	2,3	-
	20	16	105	60	-	65	150	-	4 x 11	3,5	-
	25	16	115	65	-	75	160	-	4 x 11	4	-
	32	18	140	85	-	90	180	-	4 x 14	6,9	-
	40	18	150	90	-	100	200	-	4 x 14	8	-
	50	20	165	95	-	110	230	-	4 x 14	10,5	-
	65	20	185	120	-	130	290	-	4 x 14	16,8	-
	80	22	200	130	-	150	310	-	4 x 19	22	-
	100	24	220	155	-	170	350	-	4 x 19	32,5	-
	125	26	250	175	-	200	400	-	8 x 19	52	-
	150	26	285	195	-	225	480	-	8 x 19	72	-
200	30	340	245	-	280	600	-	8 x 19	123	-	
16	15	14	95	50	25	65	130	90	4 x 14	2,3	2,3
	20	16	105	60	35	75	150	95	4 x 14	3,5	3,5
	25	16	115	65	35	85	160	100	4 x 14	4	4
	32	18	140	85	50	100	180	105	4 x 19	6,9	6,7
	40	18	150	90	50	110	200	115	4 x 19	8	7,8
	50	20	165	95	60	125	230	125	4 x 19	10,5	10,5
	65	20	185	120	70	145	290	145	4 x 19	16,8	15,8
	80	22	200	130	75	160	310	155	8 x 19	22	20,5
	100	24	220	155	95	180	350	175	8 x 19	32,5	29,5
	125	26	250	175	105	210	400	200	8 x 19	52	48
	150	26	285	195	110	240	480	225	8 x 23	72	67
	200	30	340	245	140	295	600	275	12 x 23	123	108
	250	32	400	295	150	355	730	325	12 x 28	200	170
300	32	460	335	185	410	850	375	12 x 28	310	262	
350 ⁶⁾	36	520	335	-	470	980	-	16 x 28	357	-	

- 5) PN 6 bolt hole pattern (dimensions k and n x d₃), but flanges dimensioned to PN 16 (dimensions D and b). Please take into account when selecting flange connection bolts.
6) DN 350 only in EN-GJS-400-18-LT, straight-way pattern

Mating dimensions as per standard

Face-to-face lengths: Straight-way valve: DIN EN 558/1, ISO 5752
Angle valve: DIN EN 558/8, ISO 5752

Flanges: DIN EN 1092-2, flange type 21 for EN-GJL-250
DIN EN 1092-2, flange type 21-2 for EN-GJS-400-18-LT

Flange facing: DIN EN 1092-2, type B

Other flange designs

- Undrilled, DN 200-300 drilled to PN 10, drilled to ANSI Class 150; tongue (type C), groove (type D), spigot (type E), recess (type F) at both ends (to DIN EN 1092-1).
- Other flange designs on request

Installation information

 The flow direction must correspond to the arrow indicated on the valve body.

 A minimum pressure is required for opening. If this minimum pressure is not reached, the closing spring can be dismantled. Without closing spring, the valve shall only be installed in upright position in horizontal pipes.

Minimum opening pressures [mbar]

DN	With spring	Without spring
15-50	250	25
65-150	200	16
200-350	150	22

Chemical resistance chart

The information provided in this chemical resistance chart is based on experience, the Dechema lists as well as manufacturer information. Corrosion resistance is largely dependent on the operating conditions, temperatures and concentrations. Hydroabrasive wear in fluids containing solids is not covered in this list. All information provided herein, therefore, only serves as an orientation. Warranty claims may not be asserted on the basis of this list!

Symbols key

Symbol	Description
✓	The fluid handled is not normally aggressive toward the materials.
✗	The fluid handled is aggressive toward the materials. Valve cannot be used.
○	The material or valve can only be used under certain operating conditions. Please enquire accordingly, stating the operating conditions such as concentration, temperature, pH and composition of the fluid handled.

Chemical resistance chart for water⁷⁾

Fluids handled	A ⁸⁾	B ⁹⁾
Brackish water ¹⁰⁾	✗	✗
Service water ¹⁰⁾	✓	✓
Fire-fighting water	✓	✓
Chlorinated water (≤ 0.6 mg/kg)	✓	✓
Deionised water (demineralised water) ¹¹⁾	○	○
Distilled water ¹¹⁾	○	○
Boiler feed water	✓	✓
Hot water	✓	✓
High-temperature hot water	✓	✓
Condensate	✓	✓
Oil-free cooling water	✓	✓
Oil-containing cooling water	✓	✓
Ozonised water (≤ 0.5 mg/kg)	✓	✓
Pure water	✓	✓
Seawater	✗	✗
Scale-forming water ¹⁰⁾	○	○
Raw water ¹⁰⁾	✓	✓
Partly desalinated water ¹¹⁾	○	○
Fully desalinated water ¹¹⁾	○	○
Municipal waste water ¹⁰⁾¹²⁾	✓	✓
Industrial waste water ¹⁰⁾¹³⁾	✓	✓

Chemical resistance chart for oils (aromatic content 5 mg/kg)

Fluids handled	A ⁸⁾	B ⁹⁾
Vegetable oils	✓	✓
Mineral oils	✓	✓
Synthetic oils	✓	✓
Crude oil	✓	✓
Petroleum	✓	✓

Fluids handled	A ⁸⁾	B ⁹⁾
Light fuel oil	✓	✓
Linseed oil	✓	✓
Oil/water emulsion ¹⁰⁾	✓	✓
Jet fuel	○ ¹⁴⁾	✓
Petrol	○ ¹⁴⁾	✓
Kerosene	○ ¹⁴⁾	✓

Chemical resistance chart for refrigerants

Fluids handled	A ⁸⁾	B ⁹⁾
Ammonium hydroxide (≤ 30 %, ≤ 25 °C)	✓	✓
Glycol (ethylene glycol)	✓	✓
Propylene glycol	✓	✓
Water/glycol mixture (20 % ≤ c ≤ 50 %, ≤ 90 °C)	✓	✓
Inorganic cooling brine, pH 7.5	✓	✓

Chemical resistance chart for thermal oils

Fluids handled	A ⁸⁾	B ⁹⁾
Synthetic thermal oils	✓	✓
Mineral-based thermal oils	✓	✓

Chemical resistance chart for acids

Fluids handled	A ⁸⁾	B ⁹⁾
Hydrochloric acid	✗	✗
Sulphuric acid (pure, technical, concentrated)	✗	✗
Sulphurous acid	✗	✗
Fatty acid	✗	✗
Nitric acid	✗	✗

Chemical resistance chart for cleaning agents

Fluids handled	A ⁸⁾	B ⁹⁾
Lye for bottle rinsers (e.g. P3) ≤ 80 °C ¹⁰⁾	○	○
Lye for metal cleaning ≤ 80 °C ¹⁰⁾	○	○

Chemical resistance chart for steam

Fluids handled	A ⁸⁾	B ⁹⁾
Saturated steam	○ ¹⁴⁾	✓

Chemical resistance chart for other fluids

Fluids handled	A ⁸⁾	B ⁹⁾
Sodium hydroxide (≤ 50 %, ≤ 50 °C)	○	○
Natural gas	✓	✓
Oil-containing compressed air	✓	✓
Dry chlorine (≤ 30 °C)	○	✓
Ammonia	✓	✓
Butane (liquefied gas)	✓	✓
Aqueous glycerine	✓	✓
Carbon dioxide (gas)	✓	✓
Carbon dioxide (aqueous solution)	✗	✗

- 7) General criteria for water to be handled by products made of non-alloyed materials: pH > 7; chlorides (Cl⁻) < 150 mg/kg; chlorine (Cl) < 0.6 mg/kg. Other factors to be considered: hardness, carbon dioxide content (CO₂), oxygen (O₂) and dissolved substances. Contact KSB if limits are exceeded!
- 8) EN-GJL-250, T_{max.} +300 °C
- 9) EN-GJS-400-18-LT, T_{max.} +350 °C
- 10) Without solids
- 11) Can only be used for installations and the respective water quality as specified in the VdTÜV 1466 or VDI 2035 guidelines. A pH ≥ 9.5 and an oxygen content of ≤ 0.02 mg/l are also recommended.
- 12) Biologically treated
- 13) Non-corrosive, non-abrasive
- 14) EN-GJS-400-18-LT is recommended for safety reasons (ductility).



KSB SE & Co. KGaA
Johann-Klein-Straße 9 • 67227 Frankenthal (Germany)
Tel. +49 6233 86-0
www.ksb.com