

Submersible Motor Pump

Amarex KRT

50 Hz

Type Series Booklet



Legal information/Copyright

Type Series Booklet Amarex KRT

All rights reserved. The contents provided herein must neither be distributed, copied, reproduced, edited or processed for any other purpose, nor otherwise transmitted, published or made available to a third party without the manufacturer's express written consent.

Subject to technical modification without prior notice.

© KSB SE & Co. KGaA, Frankenthal 03/01/2020

Contents

Waste Water..... 4

Waste Water

Submersible Motor Pump

Amarex KRT



Main applications

- Waste water management
- Service water supply systems
- Disposal
- Waste water treatment plants
- Sludge disposal

Fluids handled

- Waste water with faeces
- Activated sludge
- Digested sludge
- Raw sludge
- Gas-containing liquids
- Industrial waste water

Operating data

Operating properties

Characteristic	Value	
Flow rate	Q [m³/h]	≤ 10080
	Q [l/s]	≤ 2800
Head	H [m]	≤ 120
Fluid temperature	T [°C]	≤ +60
Motor rating	P ₂ [kW]	0,8 - 850

Design details

Design

- Fully floodable submersible motor pump
- Not self-priming
- Close-coupled design

Drive

- Three-phase asynchronous squirrel-cage motor
- Type of protection Ex db IIB (applies to explosion-proof pump sets only)
- Enclosure: IP68 to EN 60529/IEC529

Shaft seal

Depending on the motor design:

- Two bi-directional mechanical seals in tandem arrangement with liquid reservoir, with leakage chamber on some models
- Double cartridge seal with leakage chamber

Impeller type

- Various application-oriented impeller types (⇒ Page 14)

Bearings

- Various application-oriented bearings (⇒ Page 8)

Standard bearings:

- Grease-packed bearings sealed for life
- Maintenance-free

Reinforced bearings:

Drive end:





- Grease-packed bearings sealed for life
- Maintenance-free

Pump-end:

- Grease-lubricated bearings
- Can be re-lubricated

Designation
Example: Amarex KRT K 150-503/155 4 UN G-D IE3

Designation key

Code	Description	
Amarex KRT	Type series	
K	Impeller type	
	S/S-max	Impeller with cutter
	F/F-max	Free-flow impeller
	E/E-max	Closed single-channel impeller
	D	Open diagonal single-vane impeller
	K/K-max	Closed multi-channel impeller
150	Nominal discharge nozzle diameter [mm]	
503	Maximum nominal impeller diameter [mm]	
155	Motor size	
4	Number of motor poles	
UN	Motor version (⇒ Page 8)	
	UN/UE	Without explosion protection, for fluid temperatures of up to 40 °C ¹⁾
	UF	Without explosion protection, for fluid temperatures of up to 40 °C, ambient temperature up to 55 °C
	WN/WE	Without explosion protection, for fluid temperatures of up to 60 °C ¹⁾
	XN/XE	Explosion protection  II 2G Ex db h IIB T3 Gb, for fluid temperatures of up to 40 °C ¹⁾
	XF	Explosion protection  II 2G Ex db h IIB T3 Gb, for fluid temperatures of up to 40 °C, ambient temperature up to 55 °C
	YN/YE	Explosion protection  II 2G Ex db h IIB T4 Gb, for fluid temperatures of up to 40 °C ¹⁾
	ZN/ZE	Explosion protection  II 2G Ex db h IIB T3 Gb, for fluid temperatures of up to 60 °C ¹⁾
G	Material variant (⇒ Page 6)	
	G	Standard variant, grey cast iron
	G1	Like G, impeller made of duplex stainless steel
	G2	Like G, impeller made of white cast iron
	GH	Like G, impeller and discharge cover made of white cast iron
	H	Wetted parts made of white cast iron
	C1	Wetted parts made of duplex stainless steel, mechanical seal with elastomer bellows, bolts/screws made of A4
	C2	Wetted parts made of duplex stainless steel, mechanical seal with covered spring, bolts/screws made of 1.4462
D	Installation type (⇒ Page 31)	
	D	Stationary dry installation, vertical (S1 duty)
	H	Stationary dry installation, horizontal (S1 duty)
	K	Stationary wet installation (S1 duty with motor outside the fluid possible) with guide wire arrangement or guide rail arrangement
	S	Stationary wet installation (S1 duty with submerged motor) with guide wire arrangement or guide rail arrangement
	P	Transportable wet-installed model (S1 duty with submerged motor)
IE3	Motor efficiency classification ²⁾	
	³⁾	No efficiency classification
	IE3	Premium Efficiency

- 1) Maximum fluid temperature and ambient temperature
- 2) IEC 60034-30 standard not binding for submersible motor pumps. Efficiencies calculated/determined according to the measurement method specified in IEC 60034-2. The marking is used for submersible motors that achieve efficiency levels similar to those of standardised motors acc. to the IEC 60034-30 standard.
- 3) Blank

Materials

Overview of available materials

Part No.	Description	Material variant						
		G	G1	G2	GH	H	C1	C2
Pump set								
101	Pump casing	EN-GJL-250			EN-GJN-HB555		1.4517	
135	Wear plate ⁴⁾	EN-GJL-250			-			
163	Discharge cover	EN-GJL-250			EN-GJN-HB555		1.4517	
210	Shaft	1.4021 (⇒ Page 8)					1.4021/1.4462/C45+N (⇒ Page 8)	
230	Impeller ⁵⁾	EN-GJL-250	1.4517	EN-GJN-HB555			1.4517	
350	Bearing housing	EN-GJL-250					1.4517/EN-GJL-250	
412	O-ring	Nitrile butadiene rubber (NBR)						Viton (FKM)
433.01 / 433	Mechanical seal (drive end) Double mechanical seal (drive end)	Carbon/SiC						
433.02 / 433	Mechanical seal (pump end) Double mechanical seal (pump end)	SiC/SiC						
502	Casing wear ring ⁶⁾	EN-GJL-250			VG 434			
66-2	Cooling jacket	1.4571			-			
811	Motor housing	EN-GJL-250					1.4517	
824	Power cable	(⇒ Page 13)						
900	Bolts/screws	A4 ⁷⁾						1.4462
Installation parts								
572	Guide wire suspension bracket	1.4571 up to DN 200; EN-GJL-250 from size K200-502						1.4571
59-24	Guide wire	1.4401						1.4401/ Tefzel
72-1	Flanged bend	EN-GJL-250			EN-GJN-HB555		1.4517	
732	Holder	EN-GJL-250 or EN-GJS-400-15/EN-GJS-500-7					1.4517	
885	Lifting chain / lifting rope	Lifting chain: 1.4404 Lifting rope: polyamide / polypropylene					Lifting rope: polypropylene	
892	Foot plate / feet	1.0038 + Z					1.4571	1.4517/ 1.4462
894	Mounting bracket	1.4571 up to DN 200; 1.0038 + Z from size K200-502						1.4571

Description of materials

Grey cast iron EN-GJL-250 (lamellar graphite cast iron)

Lamellar graphite cast iron to EN 1561 is the most widely used cast material for handling municipal sewage, waste water and sludges as well as stormwater and surface water. It is suitable for neutral fluids which are only slightly aggressive and cause little wear. The pH should be ≥ 6.5 , the sand content ≤ 0.5 g/l.

Duplex stainless steel (1.4517 or technically equivalent material)

This type of carbon steel is resistant to cavitation, has excellent strength values and is used for high circumferential speeds. An excellent resistance to pitting corrosion makes ferritic-austenitic stainless carbon steel a popular choice for pumping acidic waste water with a high chloride content as well as seawater and brackish water. Thanks to its good chemical resistance, e.g. against waste water containing phosphorous and sulphuric acid, this material is used in a wide range of applications in the chemical industry and process engineering. Pumps made of duplex stainless steel have a very long service life, even when handling brines, chemical waste water (pH 1 - 12), grey water and landfill leachate.

Wear-resistant white cast iron (EN-GJN-HB555 [XCR14] or technically equivalent material)

Wear-resistant white cast iron is suitable for handling highly abrasive fluids containing sand, ash or iron ore sinter, for example. It has a Rockwell hardness of at least 54 HRC, which is higher than that of hardened chrome steel. Owing to its hardness, the chromium-molybdenum alloy cast iron features a notably higher wear resistance than EN-GJL-250 grey cast iron and other cast materials. The pH value should be ≥ 6.5 .

-
- 4) For D impeller
5) D impeller: EN-GJL-250, with hardened edges
6) For E impeller and K impeller
7) Equivalent to 1.4571

Product benefits

- Absolutely water-tight resin-sealed cable entries prevent any water from entering the motor – even in the event of a damaged cable.
- Reliable operation ensured by leakage sensors signalling any ingress of moisture into the motor
- Reliable operation ensured by sensors monitoring the motor temperature and preventing overheating
- Non-clogging low-maintenance design with large free passages reduces clogging risk and, consequently, maintenance work.
- High-efficiency motors and variable hydraulic systems for optimum hydraulic efficiency and energy efficiency

Material variants C1 and C2:

- Long service life due to corrosion-resistant wetted parts made of stainless steel

Acceptance tests and warranty

Functional test

- Every pump undergoes functional testing to KSB standard ZN 56525.
- Operating data is guaranteed to DIN EN ISO 9906 / HI / 2B.

Acceptance inspections/tests

- Acceptance test to ISO/DIN or comparable standards available against a surcharge.

Warranty

- Quality is assured by means of an audited and certified quality assurance system to DIN EN ISO 9001.

Selection information

- The indicated heads and performance data apply to material variant G, for fluids with a density $\rho = 1 \text{ kg/dm}^3$ and a kinematic viscosity $\nu \leq 20 \text{ mm}^2/\text{s}$.
- For hydraulic acceptance tests of different material variants reduce the documented efficiencies by 2 percent.

Impeller type

- S, F, E, and D impellers can only be supplied with the documented impeller diameters. Indicate the pump set designation and the impeller diameter in the purchase order.
- K impellers are trimmed to the duty point. Indicate the H/Q data or the impeller diameter in the purchase order. In the hydraulic selection program, the impeller diameter is automatically computed based on the H/Q data and added to the designation of the pump set.

Pump input power

- Adjust the power input to the density of the fluid handled:

$$P_2 \text{ (required)} = \rho \text{ [kg/dm}^3\text{]} \text{ (fluid handled)} \times P_2 \text{ (documented)}$$
- Select the operating point with the largest power input within an operating range. Select a motor size providing a power reserve to compensate the tolerances in the system characteristic / pump characteristic.

Recommended motor power reserve⁸⁾

P ₂ [kW]	Reserve	
	Mains operation	With frequency inverter
≤ 30	10 %	15 %
> 30	5 %	10 %

- For installation types D and K (with cooling jacket) with motors UN/XN/YN an additional power reserve of 1.5 kW must always be added for the cooling circuit.

i In the case of waste water, too low a flow velocity in the discharge line will lead to clogging and increased wear. The flow velocity in the vertical riser must not fall below 2 m/s.

i In the case of waste water, too low a circumferential speed of the impeller will lead to clogging of the hydraulic system (frequency inverter operation). A minimum circumferential speed (measured at the impeller diameter) of 12 m/s must be observed.⁹⁾

8) If larger power reserves are stipulated by local regulations, these larger reserves must be provided.
 9) For F impellers, a circumferential speed below 12 m/s is permissible.

Overview of product features / selection tables

Overview of product features

Material variants G, G1, G2, GH

Feature	Motor							
2 poles	3 2 E ... 26 2 E	-	55 2 E ... 75 2 E	18 2 F ... 37 2 F	-	-	-	-
4 poles	2 4 E ... 22 4 E	30 4 E ... 37 4 E	45 4 E ... 75 4 E	15 4 F ... 37 4 F	35 4 N ... 110 4 N	130 4 N ... 175 4 N	200 4 N ... 350 4 N	-
6 poles	7 6 E ... 18 6 E	22 6 E ... 30 6 E	31 6 E ... 55 6 E	15 6 F ... 30 6 F	32 6 N ... 100 6 N	120 6 N ... 165 6 N	190 6 N ... 480 6 N	530 6 N ... 850 6 N
8 poles	-	11 8 E ... 22 8 E	30 8 E ... 45 8 E	15 8 F ... 22 8 F	26 8 N ... 75 8 N	90 8 N ... 130 8 N	150 8 N ... 400 8 N	460 8 N ... 760 8 N
10 poles	-	-	-	-	-	40 10 N ... 90 10 N	110 10 N ... 350 10 N	390 10 N ... 660 10 N
12 poles	-	-	-	-	-	-	105 12 N ... 300 12 N	340 12 N ... 560 12 N
Shaft material								
Shaft	1.4021							
Shaft protecting sleeve	-				1.4021 ¹⁰⁾	1.4021		
Bearing assembly	Grease-packed rolling element bearings sealed for life ¹¹⁾				Regreasable rolling element bearings (pump end) grease-packed rolling element bearings sealed for life (drive end)			
Explosion protection								
Version U	Non-explosion-proof							
Version X	⊕ II2G Ex db h IIB T3 Gb							-
Version Y	⊕ II2G Ex db h IIB T4 Gb	-	⊕ II2G Ex db h IIB T4 Gb	-	-	-	-	-
Version W	Non-explosion-proof		-	Non-explosion-proof			-	-
Version Z	⊕ II2G Ex db h IIB T3 Gb	-	⊕ II2G Ex db h IIB T3 Gb	-	-	-	-	-
Motor								
Starting method	DOL (690 V only DOL) / star-delta starting						DOL	
Voltage	400 V / 380 V ¹²⁾ / 415 V ¹²⁾ / 500 V ¹²⁾ / 690 V ¹²⁾						400 V / 690 V ¹²⁾	
Cooling	Cooled by surrounding fluid / air cooling ¹³⁾		With cooling jacket	Cooled by surrounding fluid / with cooling jacket				
Immersion depth	≤ 30 m							
Power cable								
Type	See "Overview of power cables"							
Length	10 m / ≤ 40 m ¹²⁾							
Cable gland	Totally watertight							
Sealing elements								

10) For maximum nominal impeller diameters 400 mm / 401 mm / 402 mm / 403 mm: without shaft protecting sleeve

11) For versions with D impeller and motors 55 2 E ... 75 2 E, 45 4 E ... 75 4 E, 31 6 E ... 55 6 E, 30 8 E ... 45 8 E: regreasable rolling element bearings (pump end) / grease-packed rolling element bearings sealed for life (drive end)

12) Optional

13) Optional for motors 11 2 E ... 26 2 E, 7 4 E ... 22 4 E, 7 6 E ... 18 6 E

Feature	Motor							
2 poles	3 2 E ... 26 2 E	-	55 2 E ... 75 2 E	18 2 F ... 37 2 F	-	-	-	-
4 poles	2 4 E ... 22 4 E	30 4 E ... 37 4 E	45 4 E ... 75 4 E	15 4 F ... 37 4 F	35 4 N ... 110 4 N	130 4 N ... 175 4 N	200 4 N ... 350 4 N	-
6 poles	7 6 E ... 18 6 E	22 6 E ... 30 6 E	31 6 E ... 55 6 E	15 6 F ... 30 6 F	32 6 N ... 100 6 N	120 6 N ... 165 6 N	190 6 N ... 480 6 N	530 6 N ... 850 6 N
8 poles	-	11 8 E ... 22 8 E	30 8 E ... 45 8 E	15 8 F ... 22 8 F	26 8 N ... 75 8 N	90 8 N ... 130 8 N	150 8 N ... 400 8 N	460 8 N ... 760 8 N
10 poles	-	-	-	-	-	40 10 N ... 90 10 N	110 10 N ... 350 10 N	390 10 N ... 660 10 N
12 poles	-	-	-	-	-	-	105 12 N ... 300 12 N	340 12 N ... 560 12 N
Elastomers	Nitrile butadiene rubber NBR / Viton = fluorocarbon rubber FPM ¹²⁾							
Shaft seal	Mechanical seal with elastomer bellows / double cartridge seal ¹²⁾	Mechanical seal with elastomer bellows / pump-end mechanical seal with covered spring ¹²⁾	Double cartridge seal	Mechanical seal with elastomer bellows / pump-end mechanical seal with covered spring ¹²⁾	Stationary mechanical seal with covered spring			
Monitoring equipment								
Winding temperature, versions U, W; installation types S, P	Temperature switches (bimetal) in the winding		-	Temperature switches (bimetal) in the winding				
Winding temperature, versions X, Y; installation types S, P	Temperature switches (bimetal) in the winding, plus PTC thermistors for explosion protection		-	Temperature switches (bimetal) in the winding, plus PTC thermistors for explosion protection			-	
Winding temperature; installation types D, H, K	PTC thermistor	-	PTC thermistor; Pt100 resistance thermometer ¹⁵⁾	PTC thermistor				
Coolant temperature; installation types D, K	-		-	PTC thermistor				
Bearing temperature	-	Pt100 resistance thermometer (pump end) ¹²⁾	Pt100 resistance thermometer (pump end) ¹⁶⁾ Pt100 resistance thermometer (drive end) ¹⁵⁾	Pt100 resistance thermometer (pump end) Pt100 resistance thermometer (drive end) ¹²⁾			Pt100 resistance thermometer (pump end) Pt100 resistance thermometer (drive end)	
Leakage in the motor space	Leakage sensor in the motor space							
Mechanical seal leakage	-		Float switch in leakage area					
Vibration sensor	-		Internal vibration sensor ¹⁵⁾	Internal vibration sensor ¹²⁾				
Coating	Environmentally friendly KSB standard coating (colour RAL 5002) / 250 µm two-component epoxy coating ¹²⁾							

14) Only for motors 3 2 E, 2 4 E, 3 4 E

15) Optional: Premium package

16) Option: Basic Plus package or Premium package

Feature	Motor							
2 poles	3 2 E ... 26 2 E	-	55 2 E ... 75 2 E	18 2 F ... 37 2 F	-	-	-	-
4 poles	2 4 E ... 22 4 E	30 4 E ... 37 4 E	45 4 E ... 75 4 E	15 4 F ... 37 4 F	35 4 N ... 110 4 N	130 4 N ... 175 4 N	200 4 N ... 350 4 N	-
6 poles	7 6 E ... 18 6 E	22 6 E ... 30 6 E	31 6 E ... 55 6 E	15 6 F ... 30 6 F	32 6 N ... 100 6 N	120 6 N ... 165 6 N	190 6 N ... 480 6 N	530 6 N ... 850 6 N
8 poles	-	11 8 E ... 22 8 E	30 8 E ... 45 8 E	15 8 F ... 22 8 F	26 8 N ... 75 8 N	90 8 N ... 130 8 N	150 8 N ... 400 8 N	460 8 N ... 760 8 N
10 poles	-	-	-	-	-	40 10 N ... 90 10 N	110 10 N ... 350 10 N	390 10 N ... 660 10 N
12 poles	-	-	-	-	-	-	105 12 N ... 300 12 N	340 12 N ... 560 12 N
Maximum fluid temperature								
Version U	40 °C							
Versions X, Y	40 °C							
Version W	60 °C		-		60 °C		-	
Version Z	60 °C		-		60 °C		-	
Tests/inspections								
Hydraulic system	KSB standard (ZN 56525) / S impeller, D impeller, E impeller, F impeller (ISO 9906/A) ¹²⁾ / K impeller (ISO 9906//1/2/A) ¹²⁾							
General	KSB standard (ZN 56525)							
Installation type								
Stationary, with guide wire	Installation depths 4.5 m / 15 m ¹⁷⁾ / ≤ 30 m ¹²⁾							
Transportable	Up to size 300-401 (except sizes 200-502/503, 200-632)			-		Up to size 300-401 (except sizes 200-502/503, 200-632)		-
Stationary, with guide rail arrangement	Installation depths 4.5 m / ≤ 30 m ¹²⁾							
Stationary, dry-installed	- / air cooling ¹³⁾			With cooling jacket		With cooling jacket		

17) From size K200-503

Material variants H, C1, C2

Feature	Motor						
2 poles	3 2 E ... 26 2 E	-	55 2 E ... 75 2 E	-	-	-	-
4 poles	2 4 E ... 22 4 E	30 4 E ... 37 4 E	45 4 E ... 75 4 E	35 4 N ... 110 4 N	130 4 N ... 175 4 N	200 4 N ... 350 4 N	-
6 poles	7 6 E ... 18 6 E	22 6 E ... 30 6 E	31 6 E ... 55 6 E	32 6 N ... 100 6 N	120 6 N ... 165 6 N	190 6 N ... 480 6 N	530 6 N ... 850 6 N
8 poles	-	11 8 E ... 22 8 E	30 8 E ... 45 8 E	26 8 N ... 75 8 N	90 8 N ... 130 8 N	150 8 N ... 400 8 N	460 8 N ... 760 8 N
10 poles	-	-	-	-	40 10 N ... 90 10 N	110 10 N ... 350 10 N	390 10 N ... 660 10 N
12 poles	-	-	-	-	-	105 12 N ... 300 12 N	340 12 N ... 560 12 N
Shaft material for material variant H							
Shaft	1.4021						
Shaft protecting sleeve	-			1.4021 ¹⁰⁾	1.4021		
Shaft material for material variants C1, C2							
Shaft	1.4462 / C45+N			1.4021 ¹⁸⁾	1.4021		
Shaft protecting sleeve	-			1.4462 ¹⁰⁾	1.4462		
Suction flange	Drilled to DIN 2501 ¹²⁾						
Bearing assembly	Grease-packed rolling element bearings sealed for life			Regreasable rolling element bearings (pump end) grease-packed rolling element bearings sealed for life (drive end)			
Explosion protection							
Version U	Non-explosion-proof						
Version X	⊕ II2G Ex db h IIB T3 Gb						-
Version Y	⊕ II2G Ex db h IIB T4 Gb					-	-
Version W	Non-explosion-proof						
Version Z	⊕ II2G Ex db h IIB T3 Gb						-
Motor							
Starting method	DOL / star-delta starting (690 V only DOL) ¹⁹⁾						DOL
Voltage	400 V / 380 V ¹²⁾ / 415 V ¹²⁾ / 500 V ¹²⁾ / 690 V ¹²⁾						400 V / 690 V ¹²⁾
Cooling	Cooled by surrounding fluid						
Immersion depth	≤ 30 m						
Power cable							
Type	See "Overview of power cables"						
Length	10 m / 40 m ¹²⁾						
Cable gland	Totally watertight						
Sealing elements							
Elastomers	Nitrile butadiene rubber NBR / Viton = fluorocarbon rubber FPM ¹²⁾ / fluorocarbon rubber FPM (C2)						

18) For maximum nominal impeller diameters 400 mm / 401 mm / 402 mm / 403 mm: 1.4462

19) Depending on the motor size and voltage

Feature	Motor						
2 poles	3 2 E ... 26 2 E	-	55 2 E ... 75 2 E	-	-	-	-
4 poles	2 4 E ... 22 4 E	30 4 E ... 37 4 E	45 4 E ... 75 4 E	35 4 N ... 110 4 N	130 4 N ... 175 4 N	200 4 N ... 350 4 N	-
6 poles	7 6 E ... 18 6 E	22 6 E ... 30 6 E	31 6 E ... 55 6 E	32 6 N ... 100 6 N	120 6 N ... 165 6 N	190 6 N ... 480 6 N	530 6 N ... 850 6 N
8 poles	-	11 8 E ... 22 8 E	30 8 E ... 45 8 E	26 8 N ... 75 8 N	90 8 N ... 130 8 N	150 8 N ... 400 8 N	460 8 N ... 760 8 N
10 poles	-	-	-	-	40 10 N ... 90 10 N	110 10 N ... 350 10 N	390 10 N ... 660 10 N
12 poles	-	-	-	-	-	105 12 N ... 300 12 N	340 12 N ... 560 12 N
Shaft seal	C1: Mechanical seal with elastomer bellows ²⁰⁾ H, C2: Double cartridge seal ²¹⁾ , pump-end mechanical seal with covered spring ²²⁾		C1: Mechanical seal with elastomer bellows ²³⁾ H, C2: pump-end mechanical seal with covered spring				Stationary mechanical seal with covered spring
Monitoring equipment	Temperature switches (bimetal) in the winding						
Winding temperature, versions U, W	Temperature switches (bimetal) in the winding, plus PTC thermistors for explosion protection ¹⁴⁾						
Winding temperature, versions X, Y	Temperature switches (bimetal) in the winding, plus PTC thermistors for explosion protection ¹⁴⁾						
Bearing temperature	-	Pt100 resistance thermometer (pump end) ¹²⁾	Pt100 resistance thermometer (pump end)	Pt100 resistance thermometer (drive end) ¹²⁾	Pt100 resistance thermometer (pump end)	Pt100 resistance thermometer (drive end)	Pt100 resistance thermometer (drive end)
Motor leakage	Leakage sensor in the motor space						
Coating	H: environmentally friendly KSB standard coating (colour RAL 5002) / H: 250 µm two-component epoxy coating ¹²⁾ / C1, C2: without coating						
Maximum fluid temperature							
Version U	40 °C		30 °C / 40 °C ²⁴⁾				
Versions X, Y	40 °C		30 °C / 40 °C ²⁴⁾				
Version W	60 °C						
Version Z	60 °C						
Tests/inspections							
Hydraulic system	KSB standard (ZN 56525) / S impeller, F impeller (ISO 9906/A) ¹²⁾ / K impeller (ISO 9906//1/2/A) ¹²⁾						
General	KSB standard (ZN 56525)						
Installation type							
Stationary, with guide wire	Installation depths 4.5 m / ≤ 30 m ¹²⁾						
Transportable	Installation depth: 4.5 m						

20) Optional: Double cartridge seal, maximum nominal impeller diameter ≤ 315 mm

21) Maximum nominal impeller diameter ≤ 315 mm

22) Maximum nominal impeller diameter > 315 mm

23) Optional: mechanical seal with covered spring

24) For material variant H

Overview of power cables

Feature	S1BN8-F rubber-sheathed cable	S07RC4N8-F rubber-sheathed cable	TEHSITE Tefzel cable
Design	Standard	Optional	Optional
Rated voltage	1000 V	750 V	750 V
EMC screening	-	✓	-
Insulation material	EPR ²⁵⁾	EPR ²⁵⁾	ETFE ²⁶⁾
Max. continuous temperature of insulation	90 °C	90 °C	135 °C
For permanent immersion in waste water to DIN VDE 0282-16/HD22.16	✓	✓	✓



25) EPR = ethylene propylene rubber
 26) ETFE = ethylene tetrafluoroethylene

Impellers

	Impeller with cutter (impeller type S/S-max)	Suitable for the following fluids: fluids containing coarse substances and/or long fibres
---	---	---

Further fluids (impeller type S/S-max):

- Domestic waste water
- Grey water
- Waste water with faeces

	Free-flow impeller (impeller type F/F-max)	Suitable for the following fluids: fluids containing solids and stringy material as well as fluids with entrapped air or entrapped gas
	Closed single-channel impeller (impeller type E/E-max)	Suitable for the following fluids: fluids containing solids and stringy material
	Open, diagonal single-channel impeller (impeller type)	Suitable for the following fluids: fluids containing solid substances and long fibres

Further fluids (impeller types F/F-max, E/E-max, D):

- Activated sludge
- Digested sludge
- Heating sludge
- Mixed water
- Raw waste water
- Raw sludge
- Recirculated sludge

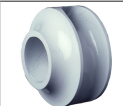
	Closed multi-channel impeller (impeller type K/K-max)	Suitable for the following fluids: contaminated, solids-laden, non-gaseous fluids without stringy material
---	--	--

Further fluids (impeller type K/K-max):

- Activated sludge
- Landfill waste water
- Industrial waste water
- Industrial grey water
- Mechanically treated waste water
- Pre-screened waste water
- Stormwater

Overview of fluids handled

The table below for your guidance is based on KSB's long-standing experience. The data are standard values and are not to be considered as generally binding recommendations. More detailed advice is available from KSB. Make use of our laboratory's expertise when selecting materials.

Selection aid for materials and hydraulic systems per fluid

Fluid handled ²⁷⁾	Recommended material	Recommended impeller type ²⁸⁾	Comments, further recommendations
Grey water	Grey cast iron	K/K-max, D, E/E-max, F/F-max	Free passage > any solids contained, possibly pre-screened
River water	Grey cast iron	K/K-max, D, E/E-max, F/F-max	Free passage > any solids contained, possibly pre-screened
Stormwater	Grey cast iron	K/K-max, D, E/E-max, F/F-max	Free passage > any solids contained, possibly pre-screened
Waste water			
▪ Untreated municipal waste water	Grey cast iron	F/F-max, S/S-max, D, E/E-max, K/K-max	ATV ²⁹⁾ recommends a free passage of 100 mm; minimum free passage: 76 mm
▪ Containing air and gas	Grey cast iron	F/F-max	Up to 8 %, contact KSB for handling fluids with high outgassing rates
Sludges			
▪ Raw sludge	Grey cast iron	F/F-max, D, E/E-max	Pumpable up to a dry substance content of: 13 % (D), 8 % (F), 6 % (E)
▪ Digested sludge	Grey cast iron	F/F-max, D, E/E-max	Pumpable up to a dry substance content of: 13 % (D), 8 % (F), 6 % (E)
▪ Activated sludge	Grey cast iron	D, K/K-max	Pumpable up to a dry substance content of: 13 % (D), 5 % (K)
Industrial waste water containing:			
▪ Paint suspensions	Grey cast iron	K/K-max	Solvent-free, observe the operator's instructions.
▪ Lacquer/paint/varnish suspensions	Grey cast iron	F/F-max, E/E-max	Solvent-free, contact KSB for silicone-free version
▪ Fibrous material	Grey cast iron	F/F-max, S/S-max, D	-
▪ Chips/swarf	Grey cast iron	K/K-max, F/F-max	Material variant G2 or GH, special mechanical seal; solids content < 5 g/l
▪ Abrasive substances ³⁰⁾	Grey cast iron	K/K-max, F/F-max	Material variant G2 or GH, special mechanical seal; solids content < 5 g/l
Mildly acidic industrial waste water	Grey cast iron	K/K-max, F/F-max	ph ≥ 6.5 material variant G1 and FPM (Viton) O-rings
Non-corrosive waste water			
▪ Ammonium water	Grey cast iron	K/K-max	-
▪ Ammonium hydroxide 5 % NH ₄ OH	Grey cast iron	K/K-max	-
▪ Urea 25 % (NH ₂) ₂ -CO	Grey cast iron	K/K-max	-
▪ Potassium hydroxide 10 % KOH	Grey cast iron	K/K-max	-

27) For any fluids which are not listed in this table contact KSB.

28) The first impeller type listed should be given preference.

29) ATV = German regulatory body for waste water management

30) Severe hydroabrasive wear occurs if solids contents of approx. 0.5 g/l or higher are combined with circumferential speeds exceeding 20 m/s or part load conditions to the left of the duty point.

Fluid handled ²⁷⁾	Recommended material	Recommended impeller type ²⁸⁾	Comments, further recommendations
▪ Calcium hydroxide 5 % Ca(OH) ₂	Grey cast iron	K/K-max	-
▪ Sodium hydroxide 5 % NaOH	Grey cast iron	K/K-max	-
▪ Sodium carbonate 30 % Na ₂ CO ₃	Grey cast iron	K/K-max	-
Non-corrosive waste water containing:			
▪ Aliphatic hydrocarbons, e.g. oils, petrol, butane, methane	Grey cast iron	K/K-max	-
▪ Aromatic hydrocarbons, e.g. benzene, styrene	Grey cast iron	K/K-max	FPM (Viton) O-rings ³¹⁾
▪ Chlorinated hydrocarbons (e.g. tetrachloroethylene, ethylene chloride, chloroform, methylene chloride)	Grey cast iron	K/K-max	FPM (Viton) O-rings ³¹⁾
Highly abrasive industrial waste water causing wear (chemically neutral) ³²⁾			
▪ Lime water	Wear-resistant white cast iron	K/K-max	Sinter contents < 5 g/l: material variant GH Sinter contents > 5 g/l: material variant H
▪ Lime milk containing quartz and pigment suspensions	Wear-resistant white cast iron	K/K-max	Lime milk contents < 15 %: material variant GH Lime milk contents > 15 %: material variant H
▪ Wash water containing solids	Wear-resistant white cast iron	K/K-max, F/F-max	Material selection based on fluid analysis
▪ Waste water containing dust or ash	Wear-resistant white cast iron	K/K-max	Material selection based on fluid analysis
Water/sand mixture	Wear-resistant white cast iron	K/K-max, F/F-max	Solids contents < 5 g/l: material variant GH Solids contents > 5 g/l: material variant H
Seawater	Duplex stainless steel	K/K-max, F/F-max	Material variant C2 ≤ 25 °C fluid temperature ³³⁾
Brackish water	Duplex stainless steel	K/K-max, F/F-max	Material variants C1 or G1 (with 250 µm two-component epoxy resin), depending on salt content
Corrosive industrial waste water	Duplex stainless steel	K/K-max, F/F-max	Material variants C1 or C2, depending on fluid analysis

31) The hydrocarbons mentioned may occur in very high concentrations due to the difference in specific weight and their low solubility. If this is the case, contact KSB.

32) The required material variants highly depend on the operating hours, rotational speed and flow velocity.

33) Higher fluid temperatures on request.

Shaft seal

Available shaft seal types per bearing bracket

UE/WE/XE/YE/ZE motors

Mechanical seal with elastomer bellows ³⁴⁾	Double cartridge seal ³⁵⁾	Pump-end mechanical seal with covered spring ³⁵⁾

UF/XF motors

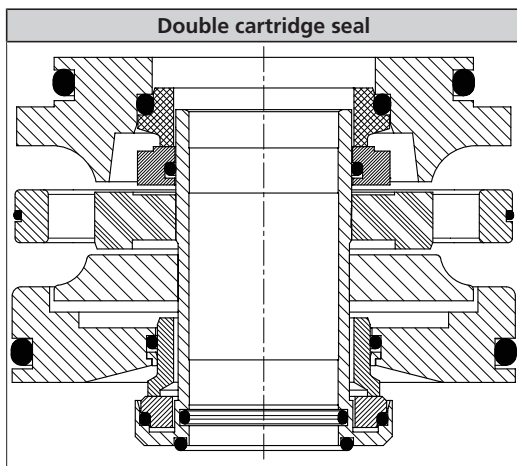

UN/WN/XN/YN/ZN motors

Mechanical seal with elastomer bellows ³⁴⁾	Pump-end mechanical seal with covered spring ³⁵⁾	Stationary mechanical seal with spring outside of fluid handled

For more information, see overview of product features. (⇒ Page 8)

2553.5/18-EN

34) For all types of waste water

35) For very abrasive fluids or fluids containing metallic particles (e.g. shavings from drilling)

Technical data

Grey cast iron (G, G1, G2, GH)

Size	Impeller type	Material variant	Impeller				Installation type				Moment of inertia J ³⁶⁾ [kgm ²]
			Impeller channels	Free passage [mm]	Max. impeller diameter [mm]	Min. impeller diameter [mm]	D, H		K, S, P		
							Maximum operating pressure ³⁷⁾ [bar]	Max. test pressure [bar]	Max. operating pressure ³⁷⁾ [bar]	Max. test pressure [bar]	
40-252	S	G	4	7	235	175	-	-	10	13	0,03
40-252	F	G, G1, G2, GH	-	25	210	150	10	15	7,6	9,8	0,03
40-252	K	G, G1, G2, GH	3	15	260	150	10	15	10	13	0,047
50-215	F	G, G1, G2, GH	-	42	210	130	10	15	8	10,5	0,019
50-216	S	G	4	4	210	175	-	-	9	12	0,018
50-216	F	G, G1, G2, GH	-	25	210	130	10	15	6,5	8,5	0,025
65-215	F	G, G1, G2, GH	-	65	210	130	6	9	5,5	7,5	0,025
65-216	E	G	1	65	180	140	6	9	5,5	7,5	0,02
65-217	F	G, G1, G2, GH	-	65	200	130	7	10,5	6	8	0,02
80-215	F	G, G1, G2, GH	-	76	200	130	5,5	8,5	4,5	6	0,025
80-216	F	G, G1, G2, GH	-	76	210	130	7	10,5	5	6,5	0,025
80-216	E	G	1	76	210	160	7	10,5	5,5	7,5	0,035
80-252	F	G, G1, G2, GH	-	76	265	150	6	9	6,3	8,2	0,14
80-253	F	G, G1, G2, GH	-	76	265	150	6	9	6,3	8,2	0,14
80-253	E	G	1	76	270	225	6	9	2,8	3,7	0,17
80-253	K	G, G1, G2, GH	2	33	220	140	6,6	10	6,6	8,6	0,15
80-315	D	G, G1	1	65	260	230	10	15	11	15	0,124
80-315	K	G, G1, G2, GH	2	33	260	140	10	15	9,1	11,9	0,11
80-317	F	G, G1, G2, GH	-	76	240	150	10	15	7	9,1	0,14
80-317	D	G, G1	1	76	220	180	10	15	6	9	0,047
100-215	F	G, G1, G2, GH	-	100	210	130	6	9	4	5,5	0,025
100-253	E	G	1	76	270	210	5,5	8,5	4,5	6	0,15
100-253	D	G, G1	1	76	265	234	6	9	3,5	4,6	0,115
100-253	K	G, G1, G2, GH	2	76	256	200	4,5	7	3,5	4,6	0,15
100-254	F	G, G1, G2, GH	-	100	265	200	6	9	3,4	4,5	0,056
100-254	K	G, G1, G2, GH	2	71	256	210	6	9	2,5	3,2	0,07
100-315	D	G, G1	1	75	222	196	10	15	6,8	8,8	0,065
100-316	D	G, G1	1	85	306	270	10	15	3,6	4,7	0,233
100-316	F	G, G1, G2, GH	-	100	310	236	6	9	4,9	6,4	0,075
100-316	K	G, G1, G2, GH	2	76	309	235	6	9	4,9	6,4	0,13
100-317	E	G	1	76	328	286	7	10,5	6	8	0,25
100-400	K	G, G1, G2, GH	2	76	408	355	10	15	9,2	12	1,1
100-401	F	G, G1, G2, GH	-	100	390	325	10	13	7,6	9,8	0,248
100-401	E	G	1	80	412	389	-	-	5,1	6,6	0,6
100-401	K	G, G1, G2, GH	2	50	404	310	10	13	9,3	12,1	0,504
150-253	D	G, G1	1	100	254	225	6	9	1,9	2,4	0,15
150-315	F	G, G1, G2, GH	-	120	290	250	6	9	1,8	2,3	0,144
150-315	D	G, G1	1	100	317	280	6	9	3,3	4,3	0,289
150-317	E	G	1	110	320	254	6	9	3,1	4,1	0,31
150-317	K	G, G1, G2, GH	2	76	309	250	6	9	5	6,5	0,28
150-400	D	G, G1	1	100	363	326	10	15	5,2	6,8	0,573
150-400	K	G, G1, G2, GH	3	76	404	300	10	15	8,4	11	0,83
150-401	F	G, G1, G2, GH	-	135	390	270	10	15	4,2	5,5	0,248
150-401	E	G	1	115	407	348	10	15	6,3	8,2	0,68
150-401	D	G, G1	1	110	384	370	10	15	5,3	6,9	0,999
150-403	K	G, G1, G2, GH	2	76	408	340	10	15	8,5	11,1	0,691
150-503	K	G, G1, G2	2	100	508	400	10	15	10	13	0,91
151-403	K	G, G1, G2, GH	2	76	408	340	10	15	9,3	11,9	0,691

36) Data applies to maximum impeller diameter and impeller with water fill.

37) Permissible operating pressure = inlet pressure + pressure at Q = 0

Size	Impeller type	Material variant	Impeller				Installation type				Moment of inertia J ₃₀ [kgm ²]
			Impeller channels	Free passage	Max. impeller diameter	Min. impeller diameter	D, H		K, S, P		
							Maximum operating pressure ³⁷⁾	Max. test pressure	Max. operating pressure ³⁷⁾	Max. test pressure	
Quantity	[mm]	[mm]	[mm]	[bar]	[bar]	[bar]	[bar]	[kgm ²]			
200-401	E	G	1	120	400	319	10	15	5,7	7,4	0,86
200-315	D	G, G1	1	100	315	280	6	9	2,7	3,4	0,261
200-315	K	G, G1, G2, GH	3	70	295	245	6	9	1,9	2,4	0,22
200-316	K	G, G1, G2, GH	2	100	305	265	6	9	1,7	2,2	0,22
200-317	K	G, G1, G2, GH	3	76	309	240	3	4,5	3,5	5	0,4
200-318	K	G, G1, G2, GH	2	100	309	230	3	4,5	3	4	0,28
200-400	D	G, G1	1	100	375	355	10	15	4,2	5,5	0,825
200-402	K	G, G1, G2, GH	3	80	408	300	6,5	9,8	6,5	9,8	0,84
200-403	K	G, G1, G2, GH	2	90	408	300	6,5	9,8	6,5	9,8	0,931
200-502	K	G, G1	3	76	508	400	10	15	9,7	12,6	0,83
200-503	K	G, G1	2	90	508	400	10	15	9,8	12,8	1,636
250-400	D	G, G1	1	120	370	320	10	15	3,5	4,6	0,653
250-401	K	G, G1, G2, GH	2	105	400	310	10	15	6	7,8	0,55
250-403	K	G, G1, G2, GH	2	107	408	300	10	15	7	9,1	1,13
250-632	K	G, G1	3	105	638	500	10	15	10,6	13,8	5,684
250-900	K	G, G1	3	110	840	717	13	19,5	11,7	15,2	19,03
300-400	D	G, G1	1	150	408	375	10	15	1,7	2,2	0,925
300-400	K	G, G1, G2, GH	3	100	408	332	10	15	3,5	4,6	0,75
300-401	K	G, G1, G2, GH	2	135	408	367	10	15	2,3	2,9	0,75
300-403	K	G, G1, G2, GH	2	102	408	300	10	15	3,8	5	1,439
300-420	K	G, G1	3	100	408	370	6	9	5,6	7,3	0,95
300-500	K	G, G1	3	90	504	430	10	15	6,2	8	1,48
300-505	K	G, G1	2	102	508	400	10	15	8	10,4	2,919
350-500	K	G, G1	3	110	508	426	6	9	5,7	7,4	3,12
350-503	K	G, G1	2	140	508	400	6	9	4,6	6	4,073
350-632	K	G, G1	3	140	638	500	10	15	6,5	8,4	6,451
350-633	K	G, G1	2	135	638	500	10	15	9,4	12,2	6,979
350-710	K	G, G1	3	110	730	580	10	15	9,4	12,2	10,6
350-713	K	G, G1	2	125	738	580	13	19,5	12,2	16	14,557
400-500	K	G, G1	3	130	508	443	6	9	3,4	4,5	3,37
400-632	K	G, G1	3	142	638	527	6	9	5,7	7,41	9,074
400-900	K	G, G1	3	130	830	659	13	19,5	11,3	14,7	17,79
401-710	K	G, G1	3	165	739	587	10	15	8,8	11,5	16
401-713	K	G, G1	2	143	738	580	9	13,5	7	9,1	15,894
500-634	K	G, G1	3	132	638	500	5	7,5	4,6	6	9,503
501-710	K	G, G1	3	150	700	586	8,5	13	8,5	11,5	16
501-900	K	G, G1	3	202	908	721	9	13,5	8	10,3	45
600-520	K	G, G1	3	145	532	457	4	6	2,4	3,2	7,02
600-710	K	G, G1	3	165	736	685	4	6	4,2	5,5	16,96
700-901	K	G, G1	3	180	908	760	9	13,5	7,2	9,3	50
700-902	K	G, G1	3	190	887	680	3,5	5	3,5	4,6	40

Industrial materials (H, C1, C2)

Size	Impeller type	Material variant	Impeller				Installation type		Moment of inertia J ⁽³⁶⁾ [kgm ²]
			Impeller channels	Free passage	Max. impeller diameter	Min. impeller diameter	S, P		
							Max. operating pressure ⁽³⁷⁾	Max. test pressure	
Quantity	[mm]	[mm]	[mm]	[bar]	[bar]	[kgm ²]			
40-252	F	H, C1, C2	-	24	210	150	7,6	9,8	0,03
40-252	K	H, C1, C2	3	15	260	150	10	13	0,047
50-215	F	H, C1, C2	-	42	210	130	8	10,5	0,019
50-216	F	H, C1, C2	-	25	210	130	6,5	8,5	0,025
65-215	F	H, C1, C2	-	65	210	130	5,5	7,5	0,025
80-216	F	H, C1, C2	-	76	210	130	5	6,5	0,025
80-252	F	H, C1, C2	-	76	265	150	6,3	8,2	0,14
80-253	K	H, C1, C2	2	33	220	140	6,6	8,6	0,15
100-253	K	H, C1, C2	2	76	256	200	3,5	5	0,15
100-254	F	H, C1, C2	-	100	265	200	3,4	4,5	0,056
100-254	K	H, C1, C2	2	71	256	210	2,5	3,2	0,07
100-316	K	H, C1, C2	2	76	309	235	4,9	6,4	0,15
100-400	K	C1, C2	2	76	408	355	9,2	12	1,1
100-401	F	H, C1, C2	-	100	390	325	7,6	9,8	0,248
100-401	K	H, C1, C2	2	50	404	310	9,3	12,1	0,504
150-315	F	H, C1, C2	-	120	290	250	1,8	2,3	0,144
150-317	K	H, C1, C2	2	76	309	250	5	6,5	0,28
150-400	K	H, C1, C2	3	76	404	300	8,4	11	0,83
150-401	F	H, C1, C2	-	135	390	270	4,2	5,5	0,248
150-403	K	H, C1, C2	2	76	408	340	8,5	11,1	0,691
150-503	K	C1, C2	2	100	508	400	10	13	0,91
151-403	K	H, C1, C2	2	76	408	340	9,3	11,9	0,691
200-315	K	H, C1, C2	3	70	295	245	1,9	2,4	0,22
200-316	K	H, C1, C2	2	100	305	265	1,7	2,2	0,22
200-402	K	H, C1, C2	3	80	408	300	6,5	9,8	0,84
200-403	K	H, C1, C2	2	90	408	300	6,5	8,5	0,931
200-502	K	C1, C2	3	76	508	400	9,7	12,6	0,83
200-503	K	C1, C2	2	90	508	400	9,8	12,8	1,636
250-401	K	H, C1, C2	2	105	400	310	6	7,8	0,55
250-403	K	H, C1, C2	2	107	408	300	7	9,1	1,13
300-400	K	H, C1, C2	3	100	408	332	3,5	4,6	0,75
300-401	K	H, C1, C2	2	135	408	367	2,3	2,9	0,75
300-403	K	H, C1, C2	2	102	408	300	3,8	5	1,439
300-420	K	C1, C2	3	100	408	370	5,6	7,3	0,95
300-500	K	C1, C2	3	90	504	430	6,2	8	1,48
300-505	K	C1, C2	2	102	508	400	8	10,4	2,919
350-500	K	C1, C2	3	110	508	426	5,7	7,4	3,12
350-503	K	C1, C2	2	140	508	400	4,6	6	4,073
350-632	K	C1, C2	3	140	638	500	6,5	8,4	6,451
350-633	K	C1, C2	2	135	638	500	9,4	12,2	6,979
350-710	K	C1, C2	3	110	730	580	9,4	12,2	10,6
350-713	K	C1, C2	2	125	738	580	12,2	16	14,557
400-500	K	C1, C2	3	130	508	443	3,4	4,5	3,37
400-632	K	C1, C2	3	142	638	527	5,7	7,41	9,074
401-713	K	C1, C2	2	143	738	580	7	9,1	15,894
500-634	K	C1, C2	3	133	582	520	4,2	5,5	6,11
600-520	K	C1, C2	3	145	532	457	2,4	3,2	7,02
600-710	K	C1, C2	3	165	736	685	4,2	5,5	16,96
700-901	K	C1, C2	3	180	908	760	7,2	9,3	50
700-902	K	C1, C2	3	190	887	680	3,5	4,6	40

Moments of inertia depending on the motor

2 poles

Motor	Motor type	J [kgm ²]
3 2 E	1	0,002
4 2 E	1	0,005
5 2 E	1	0,006
7 2 E	1	0,011
11 2 E	2	0,012
15 2 E	2	0,022
18 2 E	2	0,034
22 2 E	2	0,044
26 2 E	2	0,044
55 2 E	3	0,190
65 2 E	3	0,220
75 2 E	3	0,250
18 2 F	5	0,034
22 2 F	5	0,044
26 2 F	5	0,044
30 2 F	5	0,077
37 2 F	5	0,097
55 2 F	5	0,189
65 2 F	5	0,219
75 2 F	5	0,249

4 poles

Motor	Motor type	J [kgm ²]
2 4 E	1	0,003
3 4 E	1	0,004
4 4 E	1	0,011
5 4 E	1	0,011
7 4 E	2	0,022
11 4 E	2	0,032
15 4 E	2	0,054
18 4 E	2	0,064
22 4 E	2	0,074
30 4 E	3	0,136
37 4 E	3	0,176
45 4 E	3	0,263
55 4 E	3	0,323
65 4 E	3	0,380
75 4 E	3	0,450
15 4 F	5	0,054
18 4 F	5	0,064
22 4 F	5	0,074
30 4 F	5	0,137
37 4 F	5	0,177
55 4 F	5	0,326
65 4 F	5	0,379
75 4 F	5	0,449
35 4 N	4	0,25
50 4 N	4	0,28
65 4 N	4	0,33
80 4 N	4	0,46
95 4 N	4	0,55
110 4 N	4	0,63
130 4 N	4	1,26
155 4 N	4	1,43
175 4 N	4	1,57

Motor	Motor type	J [kgm ²]
200 4 N	4	3,78
250 4 N	4	4,13
300 4 N	4	4,82
350 4 N	4	5,51

6 poles

Motor	Motor type	J [kgm ²]
7 6 E	2	0,032
11 6 E	2	0,042
15 6 E	2	0,094
18 6 E	2	0,114
22 6 E	3	0,186
30 6 E	3	0,216
31 6 E	3	0,463
37 6 E	3	0,463
45 6 E	3	0,550
55 6 E	3	0,650
15 6 F	5	0,094
18 6 F	5	0,114
22 6 F	5	0,187
30 6 F	5	0,217
31 6 F	5	0,466
37 6 F	5	0,466
45 6 F	5	0,549
55 6 F	5	0,649
32 6 N	4	0,37
40 6 N	4	0,45
50 6 N	4	0,54
60 6 N	4	0,66
80 6 N	4	0,80
100 6 N	4	0,94
120 6 N	4	1,98
140 6 N	4	2,25
165 6 N	4	2,55
190 6 N	4	7,30
225 6 N	4	8,57
260 6 N	4	9,84
320 6 N	4	14,32
360 6 N	4	15,89
400 6 N	4	17,58
440 6 N	4	19,15
480 6 N	4	20,71
530 6 N	4	32,54
580 6 N	4	37,34
630 6 N	4	42,06
690 6 N	4	46,82
770 6 N	4	51,58
850 6 N	4	56,34

8 poles

Motor	Motor type	J [kgm ²]
11 8 E	3	0,186
15 8 E	3	0,186
18 8 E	3	0,226
22 8 E	3	0,276
30 8 E	3	0,463
37 8 E	3	0,550

Motor	Motor type	J
		[kgm ²]
45 8 E	3	0,650
15 8 F	5	0,187
18 8 F	5	0,227
22 8 F	5	0,277
30 8 F	5	0,466
37 8 F	5	0,549
45 8 F	5	0,649
26 8 N	4	0,40
35 8 N	4	0,50
50 8 N	4	0,66
65 8 N	4	0,80
75 8 N	4	0,94
90 8 N	4	1,98
110 8 N	4	2,25
130 8 N	4	2,55
150 8 N	4	7,30
185 8 N	4	8,57
220 8 N	4	9,84
260 8 N	4	13,27
300 8 N	4	15,88
350 8 N	4	19,13
400 8 N	4	20,70
460 8 N	4	32,54
530 8 N	4	37,30
580 8 N	4	42,06
630 8 N	4	46,82
690 8 N	4	51,58
760 8 N	4	56,34

Motor	Motor type	J
		[kgm ²]
450 12 N	4	53,69
490 12 N	4	59,21
560 12 N	4	64,73

10 poles

Motor	Motor type	J
		[kgm ²]
40 10 N	4	1,75
60 10 N	4	1,93
75 10 N	4	2,20
90 10 N	4	2,49
110 10 N	4	7,96
150 10 N	4	9,66
190 10 N	4	11,83
230 10 N	4	17,73
270 10 N	4	20,50
310 10 N	4	23,15
350 10 N	4	25,79
390 10 N	4	37,12
430 10 N	4	42,64
475 10 N	4	48,17
535 10 N	4	53,69
600 10 N	4	59,21
660 10 N	4	64,73

12 poles

Motor	Motor type	J
		[kgm ²]
195 12 N	4	17,73
230 12 N	4	20,50
265 12 N	4	23,15
300 12 N	4	25,79
340 12 N	4	42,64
380 12 N	4	48,17

Selection charts

Amarex KRT S + *S-max, n = 2900 rpm

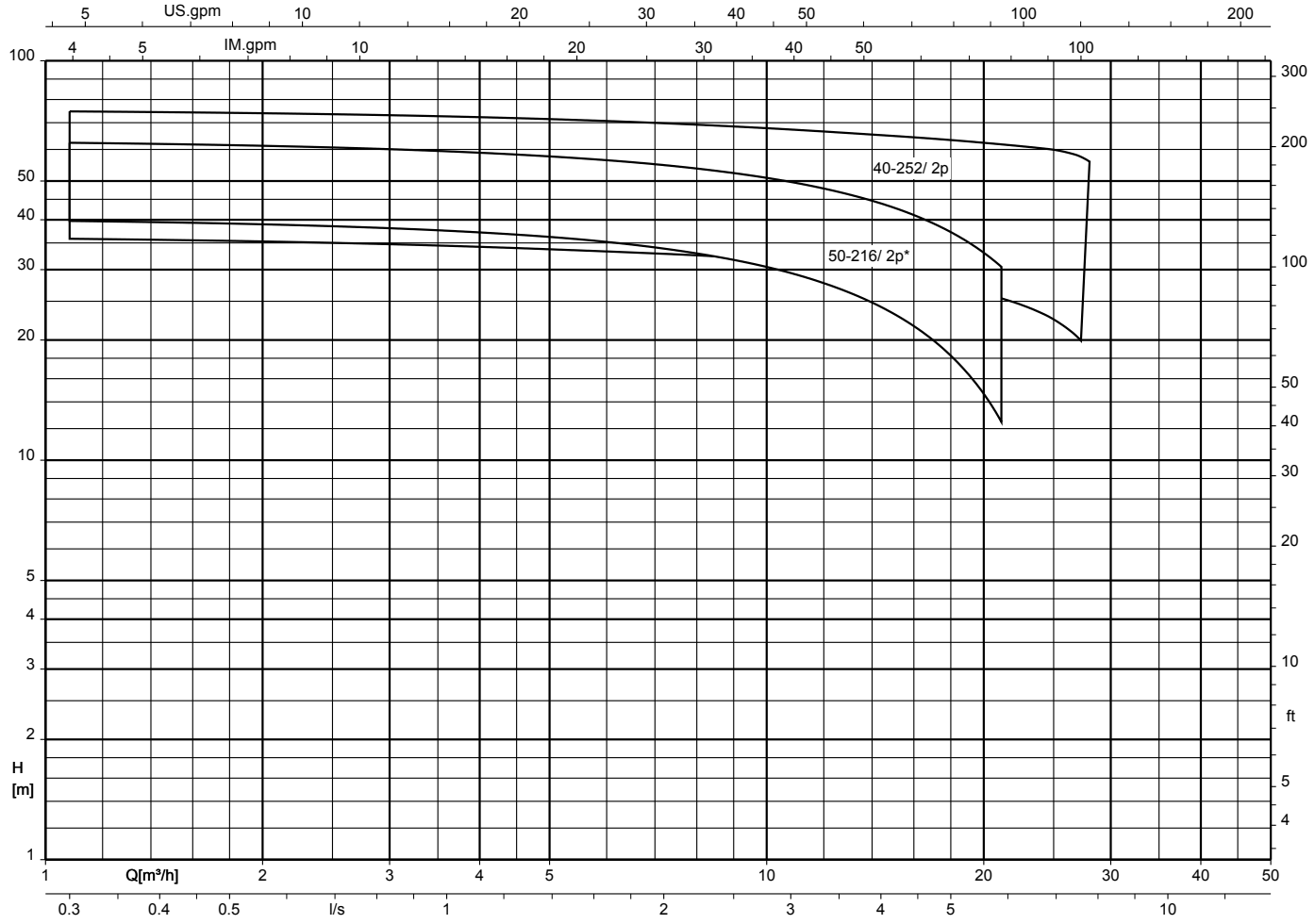

Amarex KRT F + *F-max, n = 2900/1450 rpm

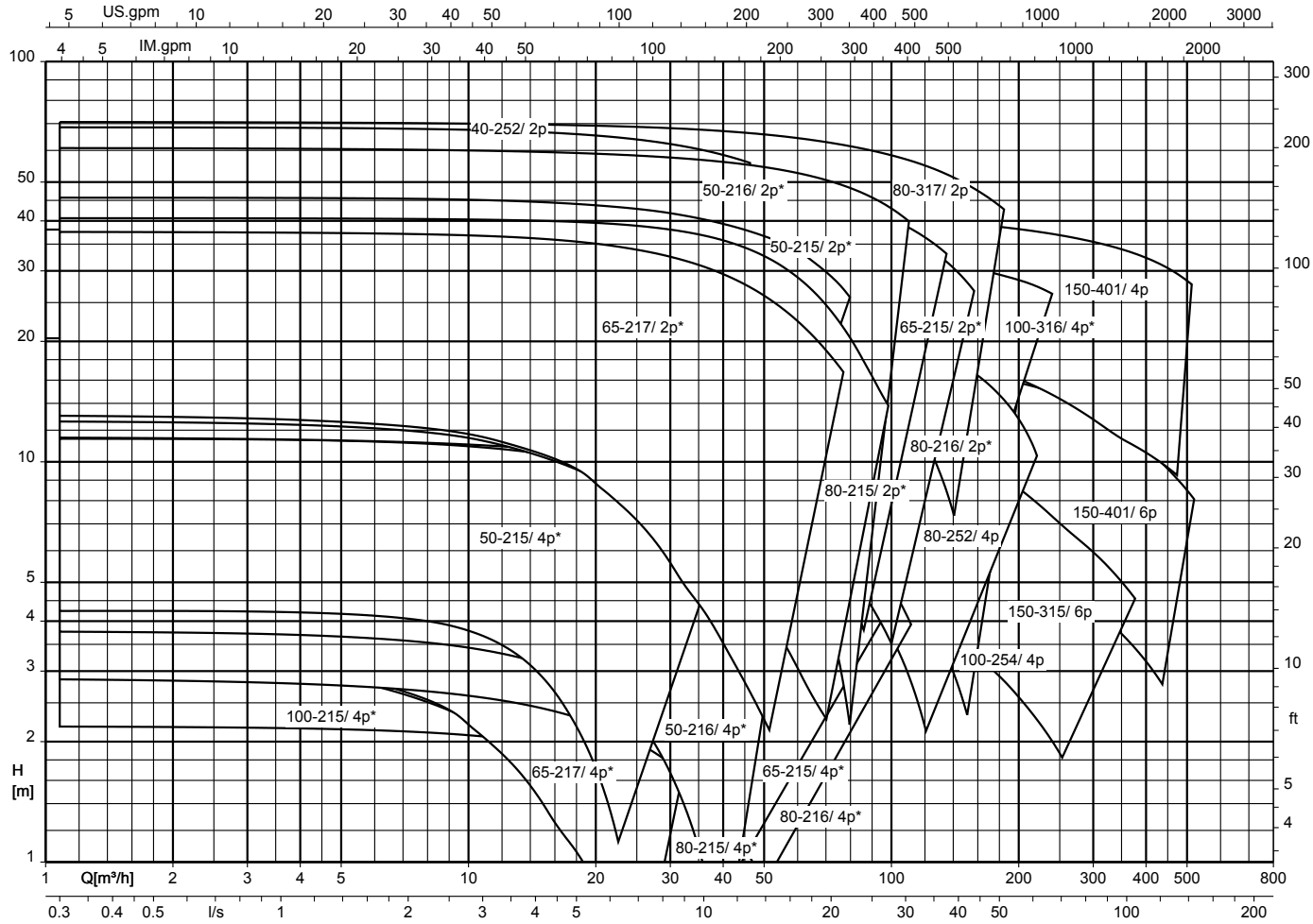

Amarex KRT E + *E-max, n = 2900/1450/960 rpm

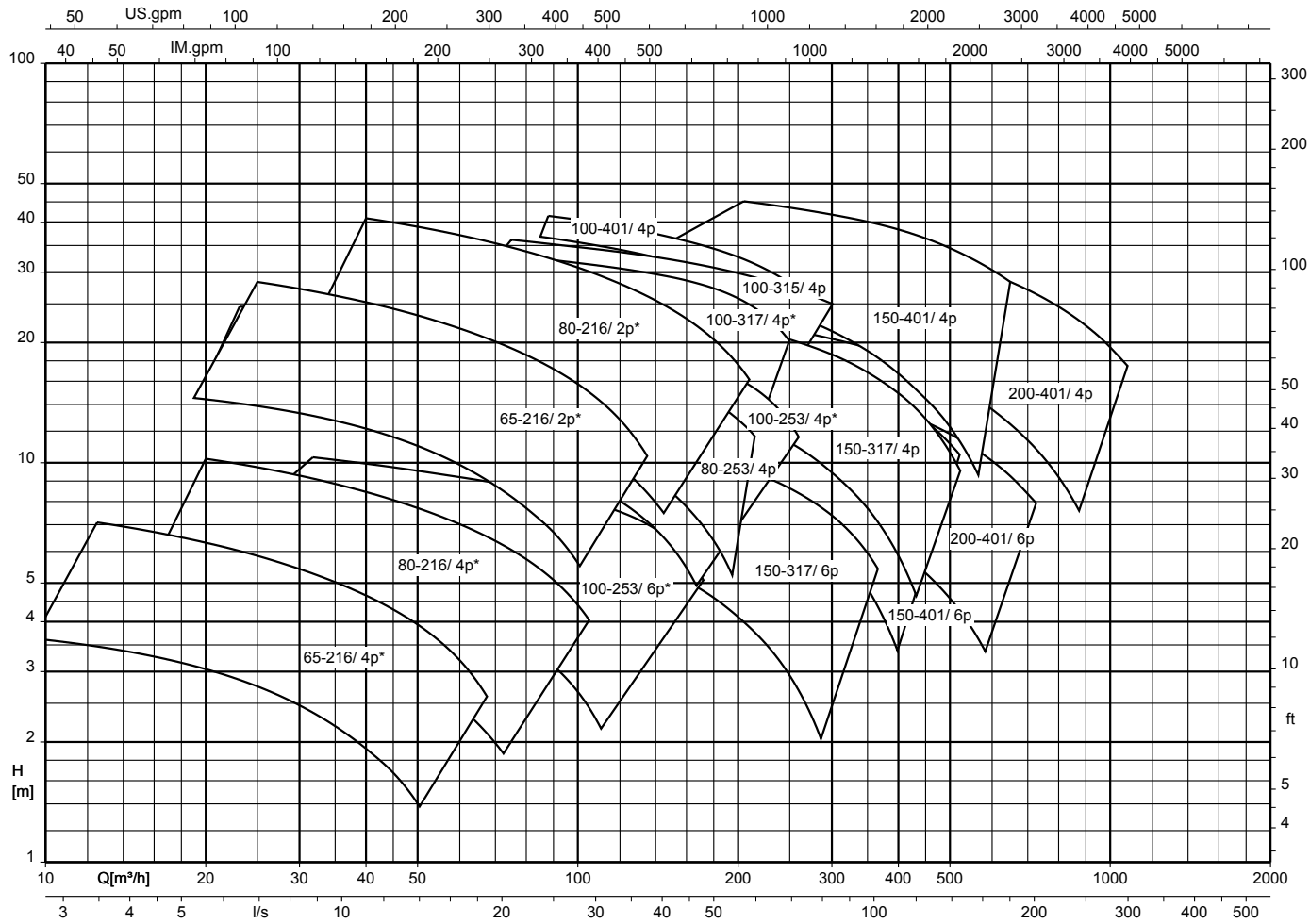

Amarex KRT D, n = 2900/1450/960 rpm

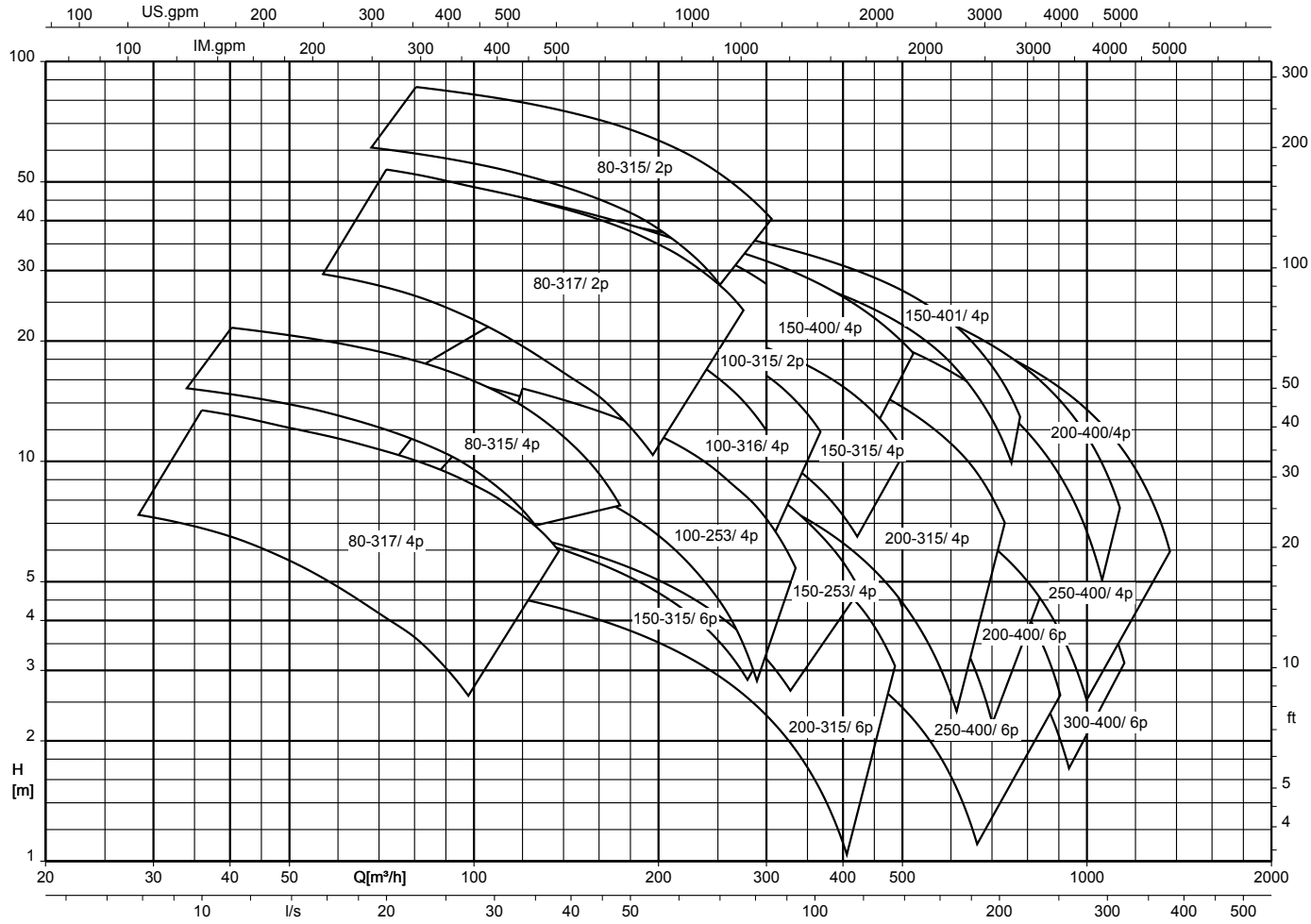

Amarex KRT K + *K-max, n = 2900/1450 rpm

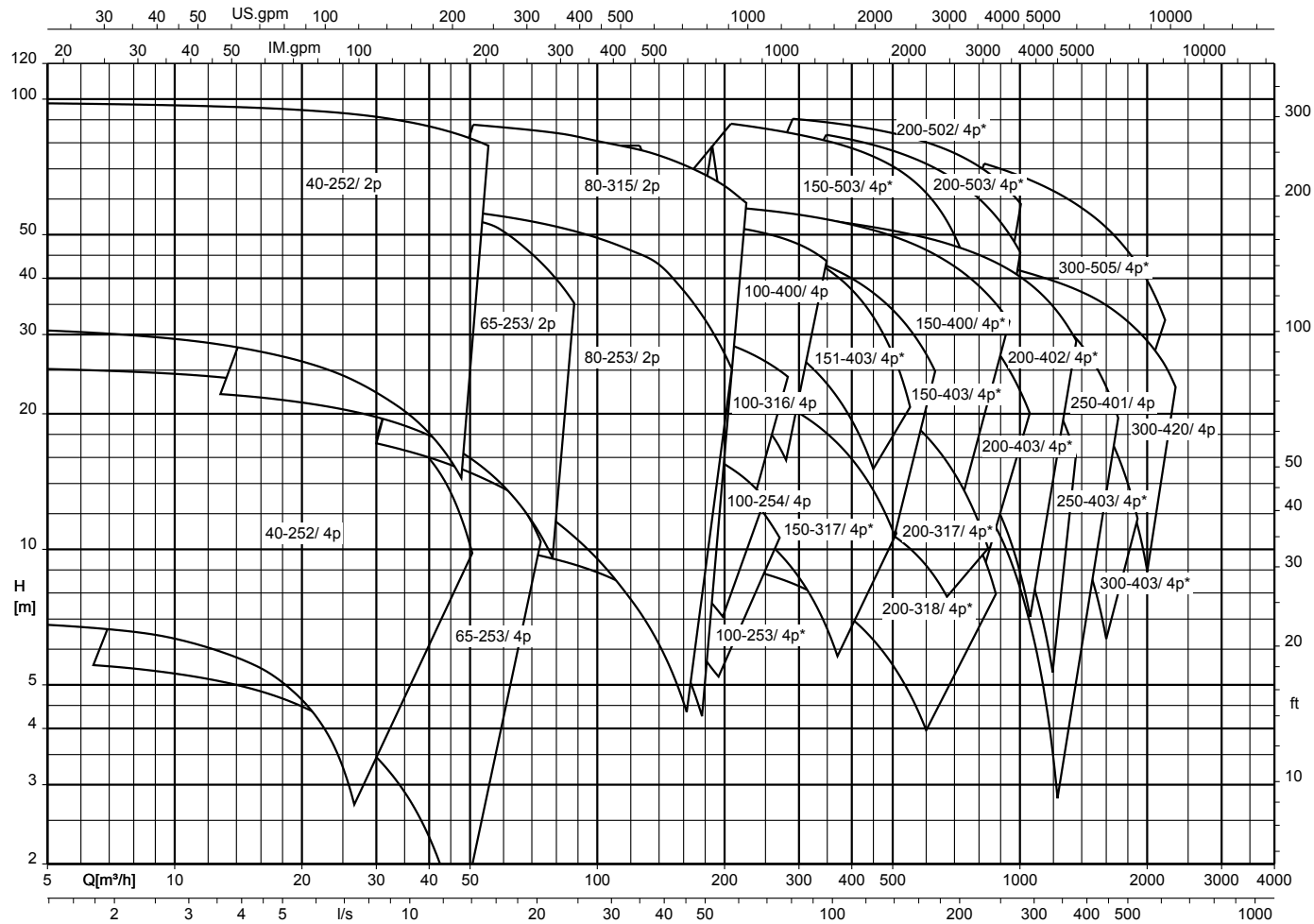

Amarex KRT K + *K-max, n = 960 rpm

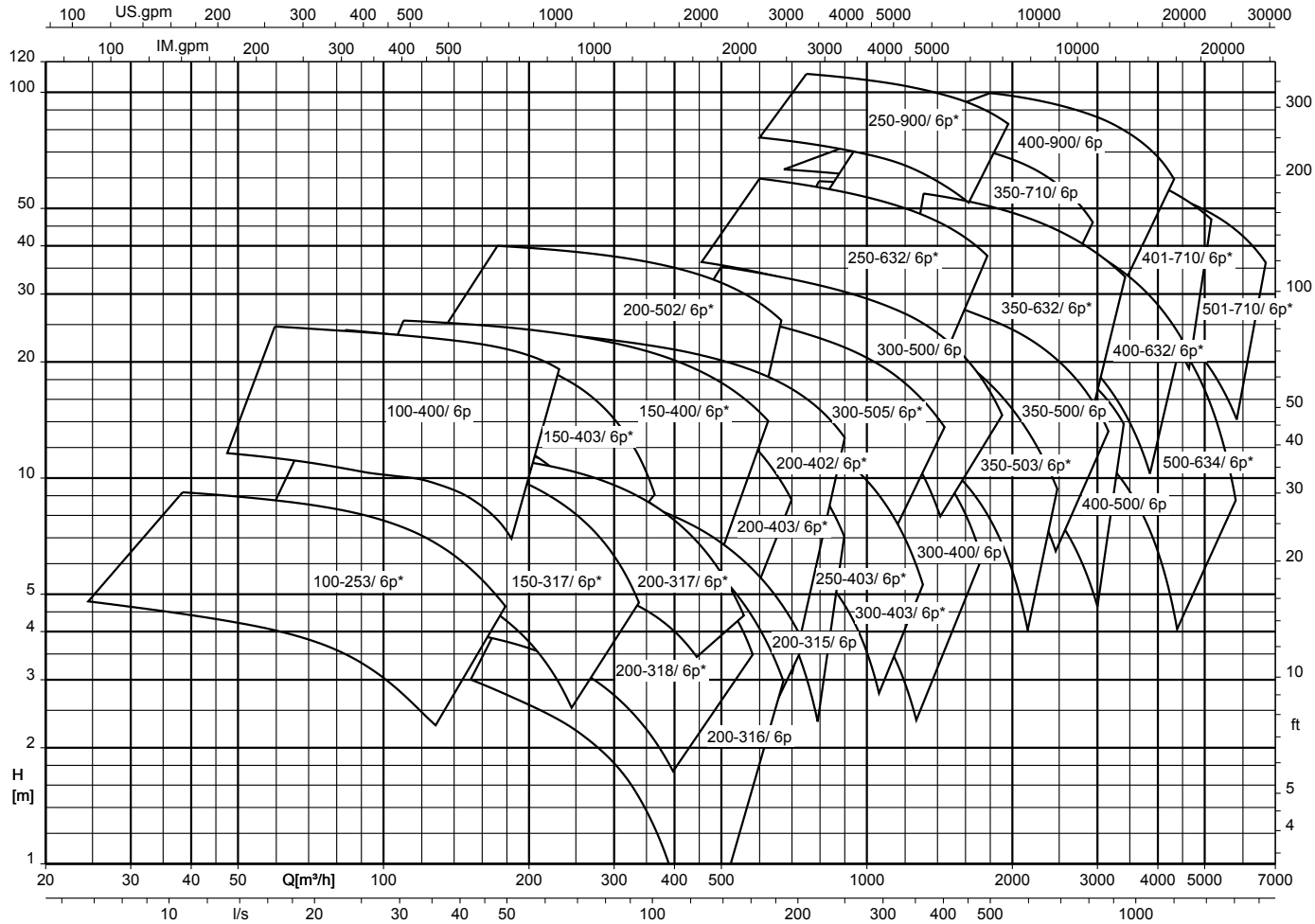

Amarex KRT K + *K-max, n = 725 rpm

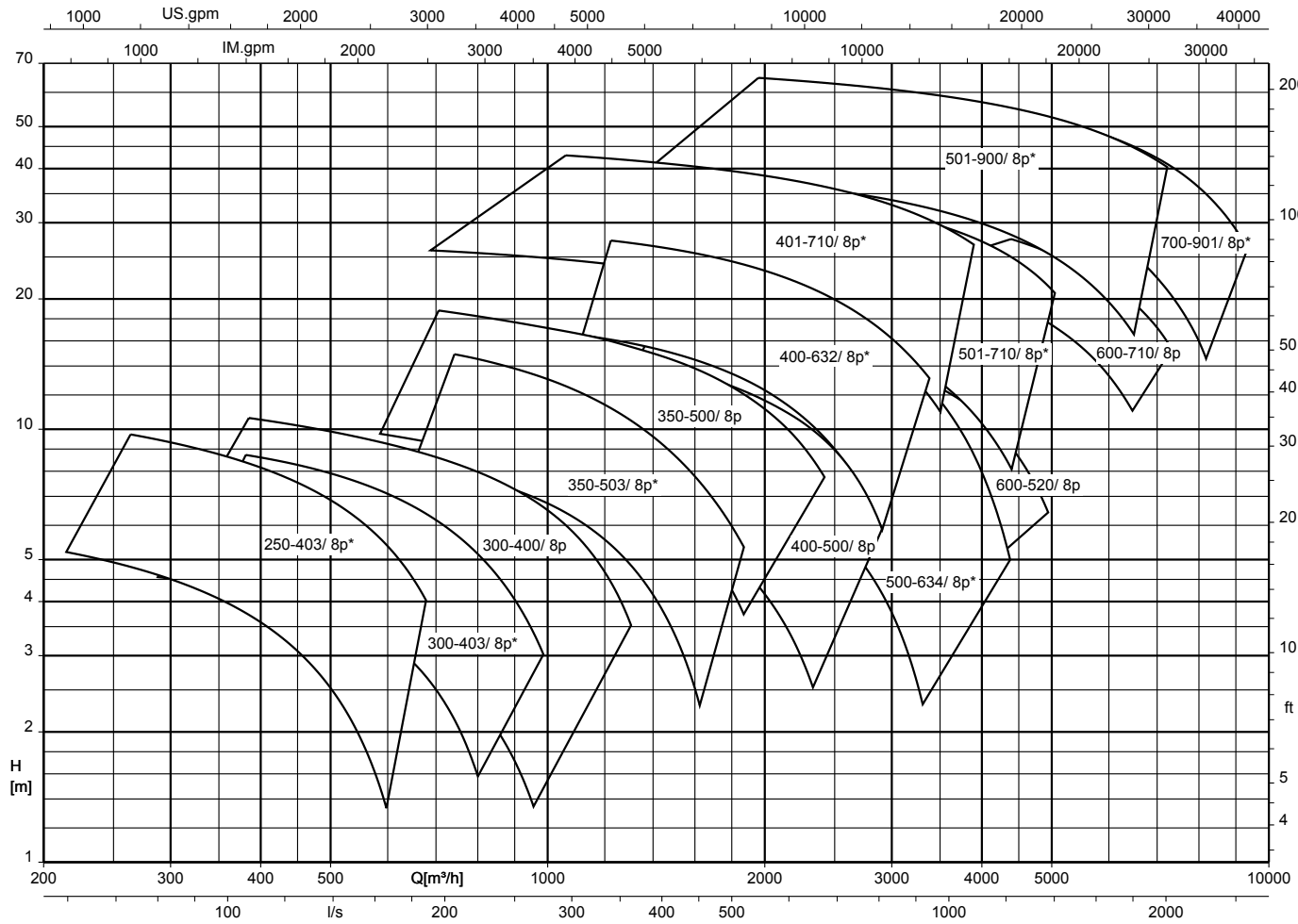

Amarex KRT K + *K-max, n = 580/480 rpm

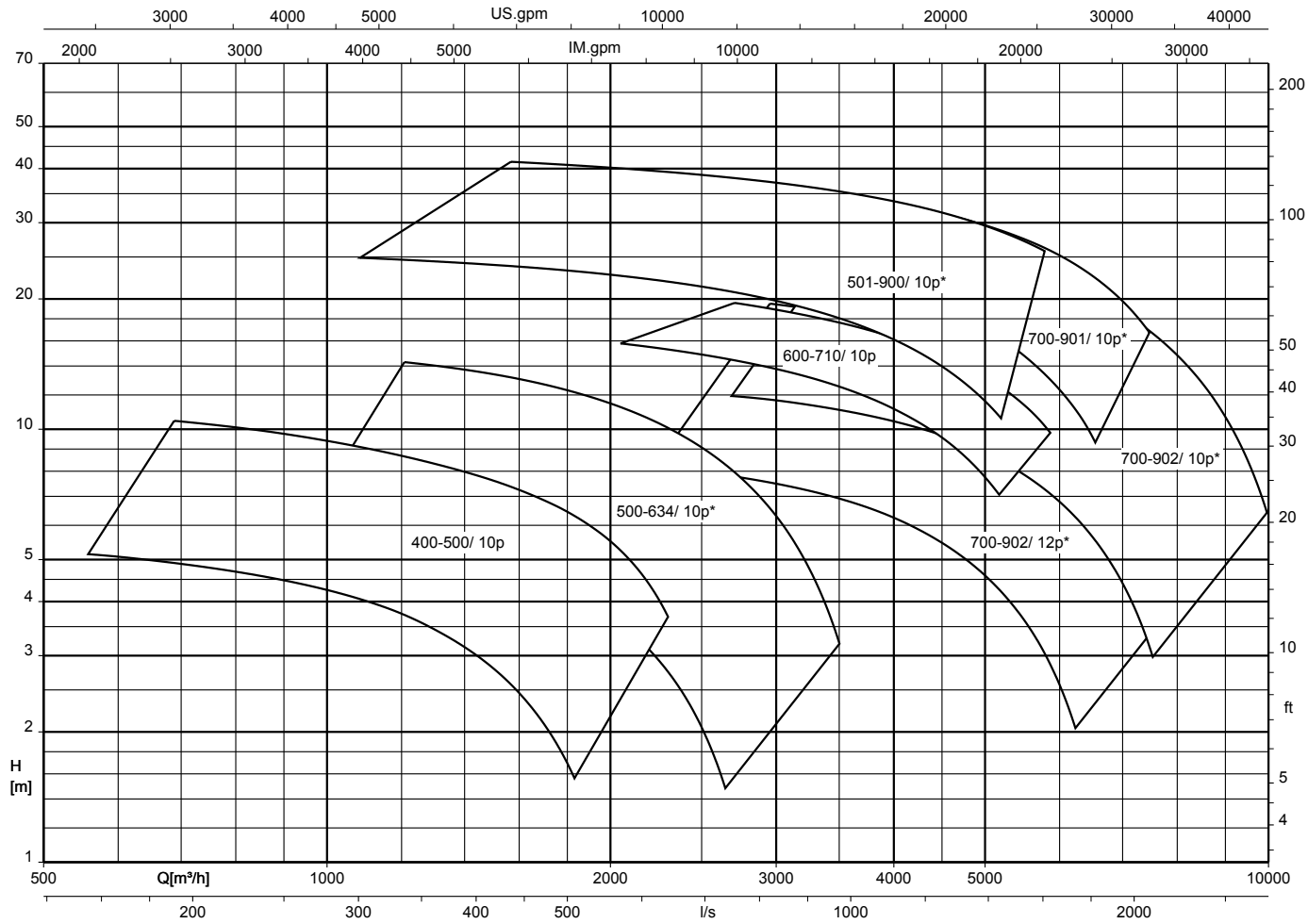

Installation types



Fig. 1: Installation types

1	Installation type D: stationary dry installation, vertical (S1 duty)
2	Installation type H: stationary dry installation, horizontal (S1 duty)
3	Installation type K: stationary wet installation (S1 duty with motor outside of the fluid possible) with guide rail arrangement Installation type S: stationary wet installation (S1 duty with submerged motor) with guide rail arrangement
4	Installation type K: stationary wet installation (S1 duty with motor outside of the fluid possible) with guide wire arrangement Installation type S: stationary wet installation (S1 duty with submerged motor) with guide wire arrangement
5	Installation type P: wet installation of transportable model (S1 duty with submerged motor)

Pump sets of installation types D, H and K

are suitable for continuous duty with the motor outside the fluid. Cooling is effected by means of air convection. Versions with a cooling jacket have an additional internal cooling circuit.

Pump sets of installation types P and S

are designed for continuously submerged operation. The motor is cooled by the fluid handled on the motor surface. Operation with the motor outside the fluid handled is possible for short periods.

Scope of supply

Stationary dry installation - vertical (installation type D)

- Pump set complete with power cables
- Duckfoot bend with inspection hole³⁸⁾ and fasteners
- Optional: suction elbow with inspection hole

Stationary dry installation - horizontal (installation type H)

- Pump set complete with power cables
- Foundation rails³⁹⁾
- Suction-side flanged spacer with inspection hole⁴⁰⁾ (optional)

Stationary wet installation (installation types K and S)

- Pump set complete with power cables
- Claw with sealing elements and fasteners
- Lifting rope, lifting chain or lifting bail (optional)
- Mounting bracket with fasteners
- Duckfoot bend with fasteners
- Guide wire / guide rail (guide rails are not included in KSB's scope of supply)

Transportable wet-installed model (installation type P)

- Pump set complete with power cables
- Foot plate or pump stool with fasteners

38) For nominal discharge nozzle diameter \geq DN 100

39) For UE/XE motors only

40) For nominal discharge nozzle diameter \geq DN 100

General assembly drawings with list of components

Amarex KRT, motor type 1

For the motor type assigned to the motor see (⇒ Page 21)

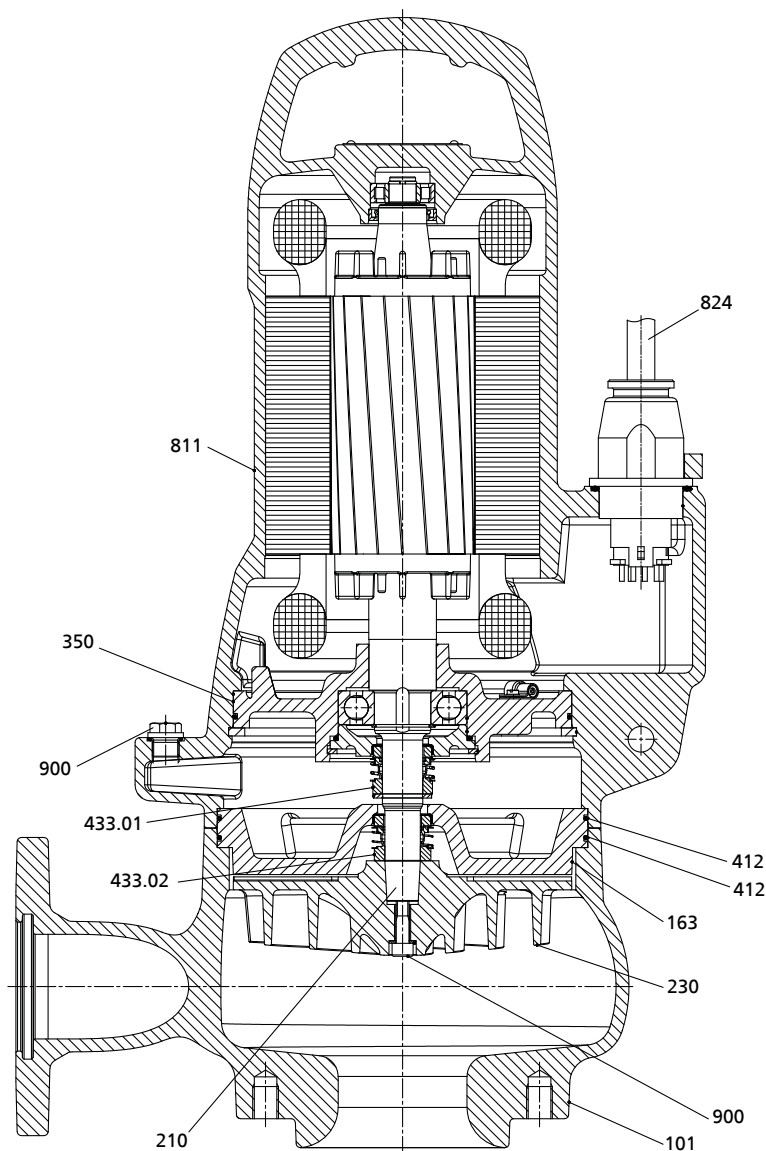

Fig. 2: General assembly drawing, example: Amarex KRT F65-215

List of components

Part No.	Description	Part No.	Description
101	Pump casing	412	O-ring
163	Discharge cover	433.01/02	Mechanical seal
210	Shaft	811	Motor housing
230	Impeller	824	Power cable
350	Bearing housing	900	Bolt/screw

Amarex KRT, motor type 2

For the motor type assigned to the motor see (⇒ Page 21)

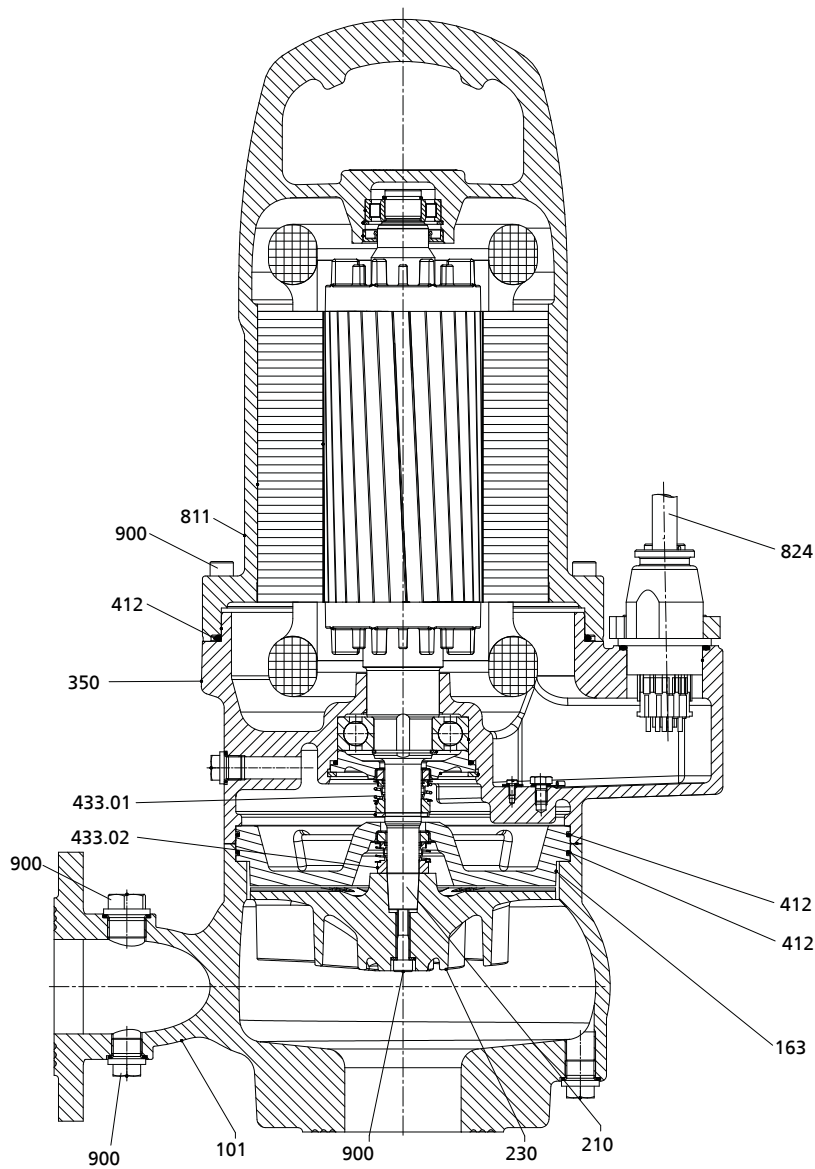

Fig. 3: General assembly drawing, example: Amarex KRT F 65-215

List of components

Part No.	Description	Part No.	Description
101	Pump casing	412	O-ring
163	Discharge cover	433.01/02	Mechanical seal
210	Shaft	811	Motor housing
230	Impeller	824	Power cable
350	Bearing housing	900	Bolt/screw

Amarex KRT, motor type 3

For the motor type assigned to the motor see (⇒ Page 21)

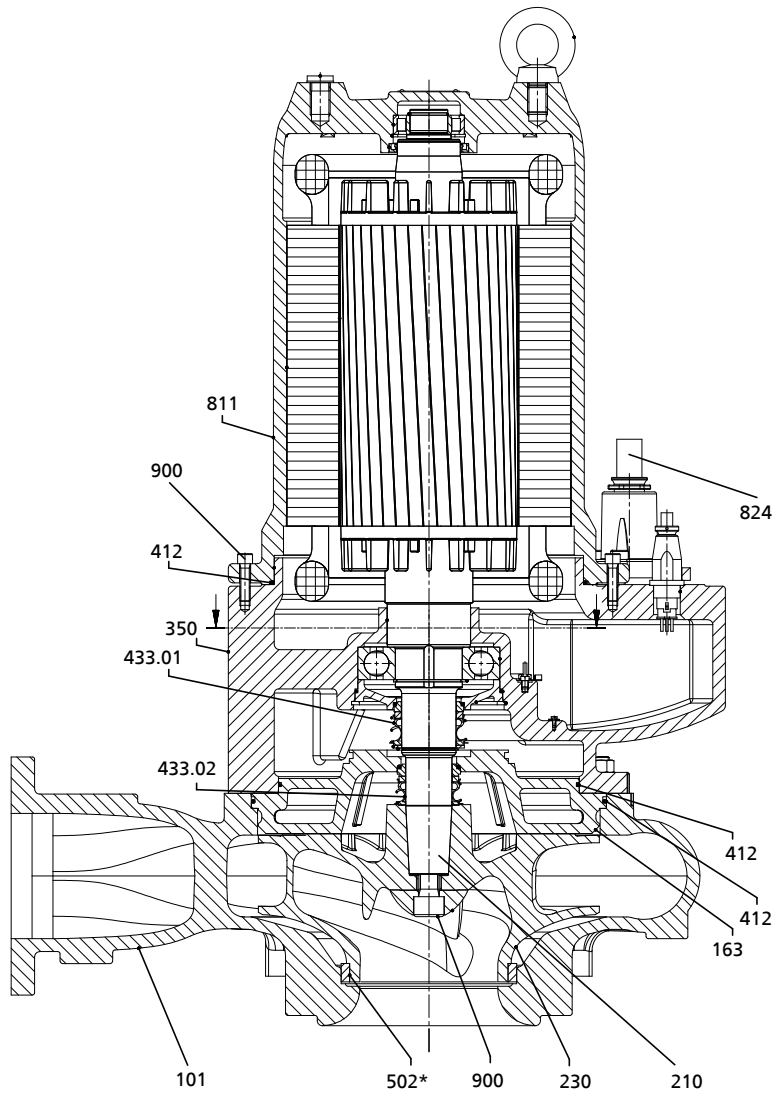

Fig. 4: General assembly drawing, example: Amarex KRT E/K 100-400/75 4 XEG

*: On specific designs only

List of components

Part No.	Description	Part No.	Description
101	Pump casing	433.01/.02	Mechanical seal
163	Discharge cover	502	Casing wear ring
210	Shaft	811	Motor housing
230	Impeller	824	Power cable
350	Bearing housing	900	Bolt/screw
412	O-ring		

Amarex KRT, motor type 4, installation types S and P

For the motor type assigned to the motor see (⇒ Page 21)

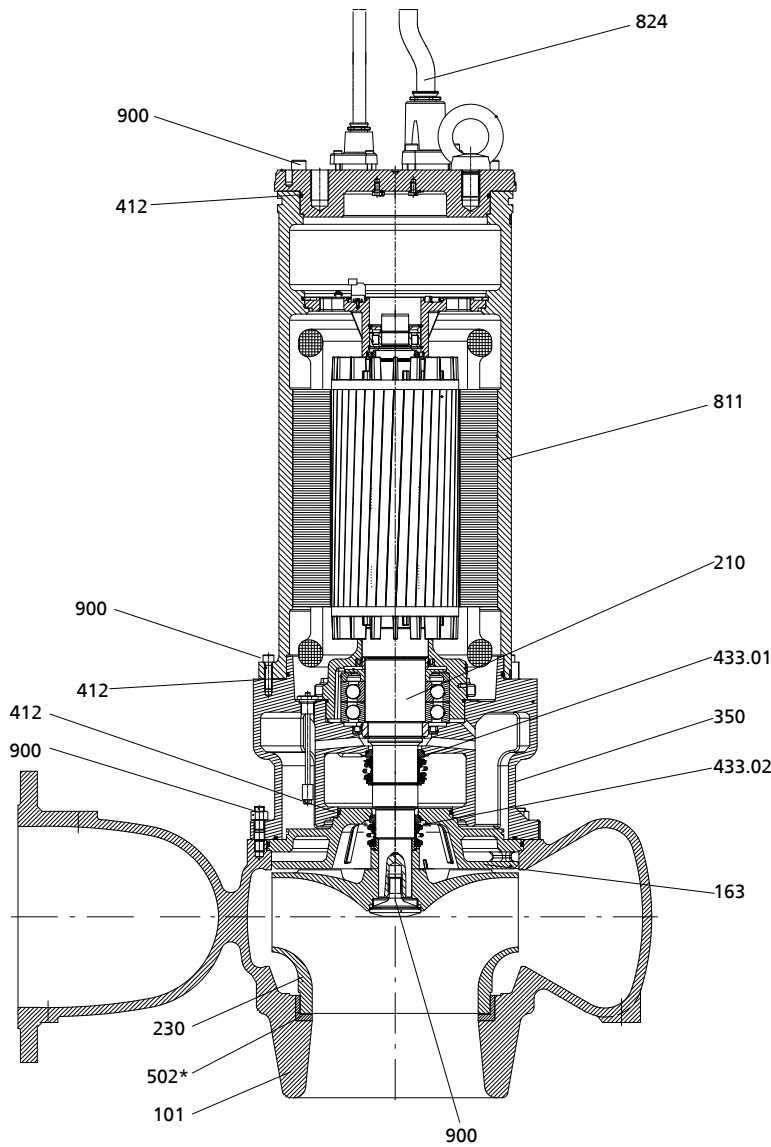

Fig. 5: General assembly drawing, example: Amarex KRT K 150-403 / 130 4 XNG-S without cooling jacket

*: On specific designs only

List of components

Part No.	Description	Part No.	Description
101	Pump casing	433.01/.02	Mechanical seal
163	Discharge cover	502	Casing wear ring
210	Shaft	811	Motor housing
230	Impeller	824	Power cable
350	Bearing housing	900	Bolt/screw
412	O-ring		

Amarex KRT, motor type 4, installation types K and D

For the motor type assigned to the motor see (⇒ Page 21)

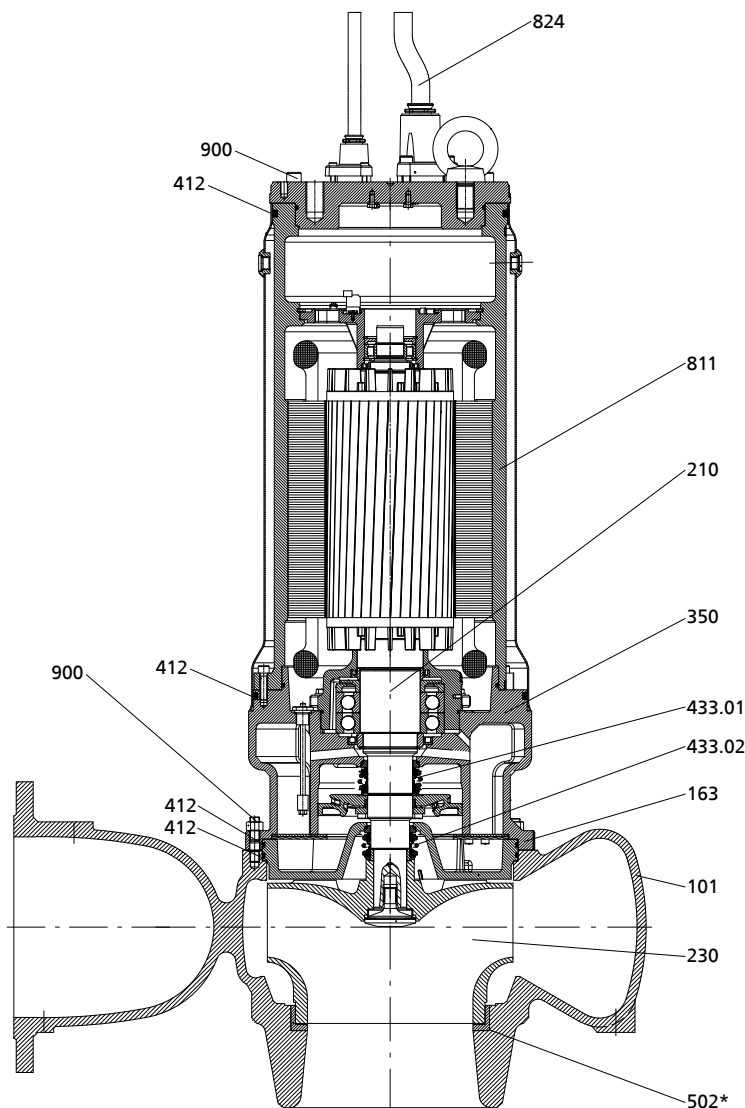

Fig. 6: General assembly drawing, example: Amarex KRT K 150-403 / 130 4 XNG-K with cooling jacket

*: On specific designs only

List of components

Part No.	Description	Part No.	Description
101	Pump casing	433.01/.02	Mechanical seal
163	Discharge cover	502	Casing wear ring
210	Shaft	811	Motor housing
230	Impeller	824	Power cable
350	Bearing housing	900	Bolt/screw
412	O-ring		

Amarex KRT, motor type 5

For the motor type assigned to the motor see (⇒ Page 21)

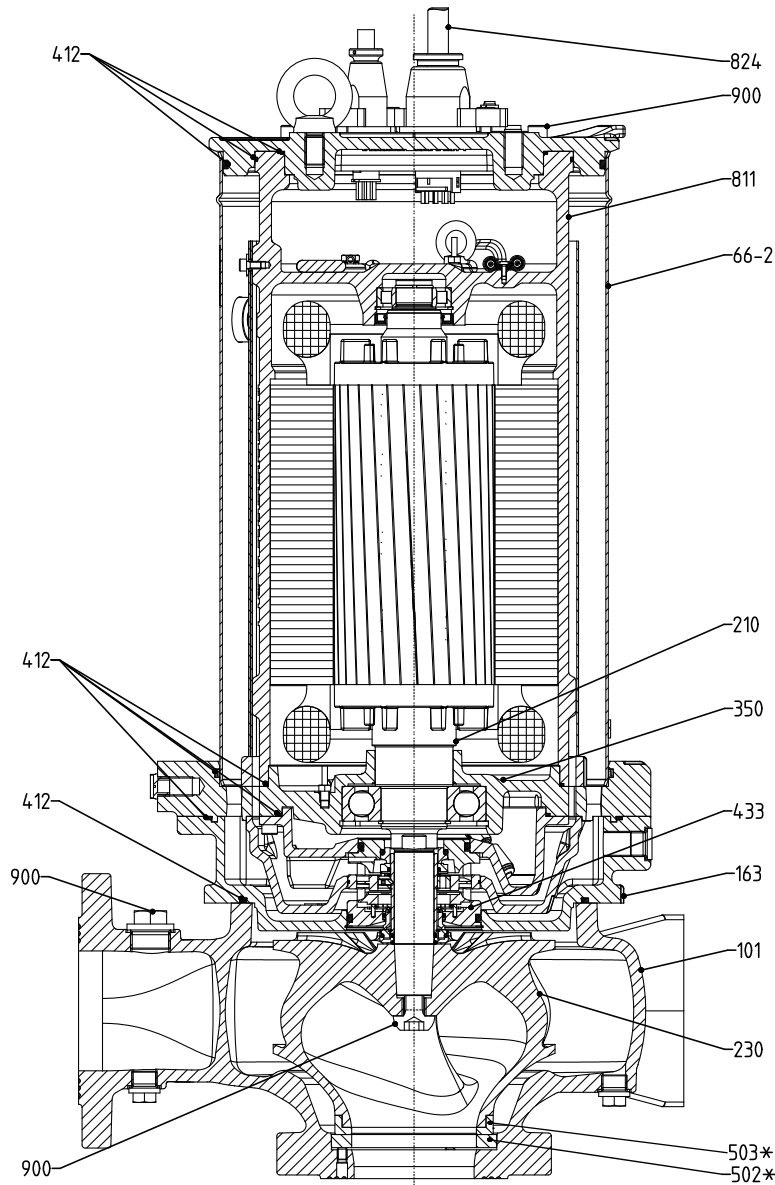

Fig. 7: General assembly drawing, example: Amarex KRT K 100-253 / 22 4 UFG-K with cooling jacket

*: On specific designs only

List of components

Part No.	Description	Part No.	Description
101	Pump casing	502	Casing wear ring
163	Discharge cover	503	Impeller wear ring
210	Shaft	66-2	Cooling jacket
230	Impeller	811	Motor housing
350	Bearing housing	824	Power cable
412	O-ring	900	Bolt/screw
433	Mechanical seal		



KSB SE & Co. KGaA
Turmstraße 92 • 06110 Halle (Germany)
Tel. +49 345 4826-0
www.ksb.com