

Dosing pumps mROY® XA and XB

Maximum flow rate: XA = 66 l/h - XB = 310 l/h • Maximum pressure: XA = 123 bar - XB = 105 bar
Hydraulically actuated diaphragm



Technical characteristics

- Flow rate up to 66 l/h for XA and 310 l/h for XB
- Pressure up to 123 bar for XA and 105 bar for XB
- Maximum temperature of pumped liquid:
 - +90 °C for metallic liquid end
 - +50 °C for plastic liquid end
- Adjustment of flow rate while running or stopped: from 0 to 100%
- Accuracy: ± 1% of rated flow from 10% to 100% stroke
- Oil bath lubricated
- Cast iron housing
- Internal safety valve
- For pressures between 10 bar and the maximum discharge pressure of the pump, capacities will decrease by approx. 2% for every 10 bar increase. Accuracy is not affected
- Maximum suction pressure condition:
 - 35 bar: for plungers Ø 11.1 (XA) and Ø 15 (XB)
 - 17.5 bar: for plungers Ø 15.9 (XA) and Ø 22.2 (XB)
 - 9 bar: for plunger Ø 22.2 (XA)
 - 6 bar: for plungers Ø 27 (XA) and Ø 36.5 (XB)
- Working life of the diaphragm can exceed 20,000 hours depending on the pumped fluid, working conditions and installation
- Compact duplex version, with 2 heads of identical or different performance and construction
- Can comply with API 675
- Explosion-proof version is in accordance with ATEX CE II 2 G/D c T5 (*plastic liquid end, please consult us*)



Pump XB with flexible coupling and double diaphragm

Electrical characteristics of motors

Standard motor data:

- Supply: 230/400 V, 3-phase, 50 Hz or 260/460 V, 3-phase, 60 Hz
- IM V1 mounting, FF130 flange, 14x30 mm shaft for XA and FF165 flange, 19x40 mm or 24x50 mm shaft for XB
- Protection: IP 55, tropicalized (90% of humidity)
- Insulation: class F
- Ambient temperature: -16 °C to +40 °C
- Motor speed: 1500 or 3000 rpm for XA and 1000 or 1500 rpm for XB
- Motors are in accordance with national and international standards
- Special or specific motors on request

Options

- Flexible coupling (API 675)
- Double diaphragm with rupture detector
- Automatic flow rate adjustment: electronic servomotor, explosion-proof servomotor, pneumatic servomotor, frequency variation
- Flange connections
- Stroke counter

Liquid end construction

COMPONENTS	CONSTRUCTION	
	PVC ⁽¹⁾	316L ⁽²⁾
Liquid end body	PVC	316L
Check valve cartridge	PVC	316L
Seats	PVC	316L
Balls	Glass	316L
Contour plate	PVC	316L
Diaphragm	PTFE	PTFE
Discharge ball spring	Hast. C	316L
Seals	Viton	Viton

⁽¹⁾ Pressure is limited to 10 bar at 20 °C and pressure derated 1.1 bar / 5 °C. Maximum operating temperature: 50 °C

⁽²⁾ Milton Roy Europe keeps an interchangeability table for national and international standards (AFNOR, DIN, ASTM, BS, etc).

OTHER LIQUID END MATERIAL

- "H₂SO₄ CONCENTRATED" version: 316L S.S. liquid end with check valve cartridge and seats in 904L; balls and spring in Hastelloy C
- "904L" version: 904L liquid end with balls and spring in Hastelloy C
- Other version on request: consult us

Performances

mROY XA - Plastic and Metallic liquid ends

Flow at 3 bar (l/h)	Plastic liquid end		316L stainless steel liquid end		Stroke speed (spm)	Plunger Ø (mm)	Diaphragm Ø (mm)	Swept volume (cm ³)	3-phase motor (kW - rpm)
	Flow at max. pressure (l/h)	Max. pressure (bar)	Flow at max. pressure (l/h)	Max. pressure (bar)					
2.6	2.5	10	1.9	123	29	11.1	71	1.74	0.25 - 1500
5.5	-	-	4	123	58	11.1	71	1.74	0.37 - 3000
5.5	5.3	10	4.8	59	29	15.9	101	3.57	0.25 - 1500
10	9	10	8	123	112	11.1	71	1.74	0.25 - 1500
22	21	10	19	59	112	15.9	101	3.57	0.25 - 1500
44	43	10	39	31	112	22.2	101	6.96	0.25 - 1500
66	65	10	64	21	112	27	101	10.3	0.25 - 1500

mROY XB - Plastic liquid end

Flow at 3 bar (l/h)	Flow at max. pressure (l/h)	Max. pressure (bar)	Stroke speed (spm)	Plunger Ø (mm)	Diaphragm Ø (mm)	Swept volume (cm ³)	3-phase motor (kW - rpm)
30	29	10	36	22.2	132	13.93	0.55 - 1000
46	45	10	56	22.2	132	13.93	0.55 - 1500
74	73	10	90	22.2	132	13.93	0.55 - 1000
80	79	10	36	36.5	132	37.66	0.55 - 1000
114	113	10	140 ^(*)	22.2	132	13.93	0.75 - 1500
124	123	10	56	36.5	132	37.66	0.55 - 1500
200	199	10	90	36.5	132	37.66	0.55 - 1000
310	309	10	140 ^(*)	36.5	132	37.66	0.75 - 1500

mROY XB - Metallic liquid end

Flow at 3 bar (l/h)	Flow at max. pressure (l/h)	Max. pressure (bar)	Stroke speed (spm)	Plunger Ø (mm)	Diaphragm Ø (mm)	Swept volume (cm ³)	3-phase motor (kW - rpm)
14	11	105	36	15	86	6.36	0.55 - 1000
21	17	105	56	15	86	6.36	0.75 - 1500
30	28	49	36	22.2	132	13.93	0.55 - 1000
30	26	100	36	22.2	132	13.93	0.75 - 1000
34	27	105	90	15	86	6.36	0.55 - 1000
46	40	100	56	22.2	132	13.93	0.75 - 1500
53	43	105	140 ^(*)	15	86	6.36	0.75 - 1500
74	70	49	90	22.2	132	13.93	0.55 - 1000
74	65	100	90	22.2	132	13.93	0.75 - 1000
80	78	14	36	36.5	132	37.66	0.55 - 1000
80	77	28	36	36.5	132	37.66	0.75 - 1000
114	109	49	140 ^(*)	22.2	132	13.93	0.75 - 1500
114	103	100	140 ^(*)	22.2	132	13.93	1.10 - 1500
124	120	28	56	36.5	132	37.66	0.75 - 1500
200	196	14	90	36.5	132	37.66	0.55 - 1000
200	193	28	90	36.5	132	37.66	0.75 - 1000
310	304	14	140 ^(*)	36.5	132	37.66	0.75 - 1500
310	299	28	140 ^(*)	36.5	132	37.66	1.10 - 1500

^(*) Do not use with 60 Hz motor



Dimensions mROY XA (in mm)

Simplex version - Metallic liquid end

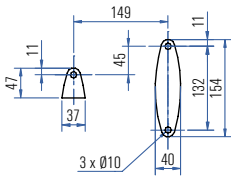
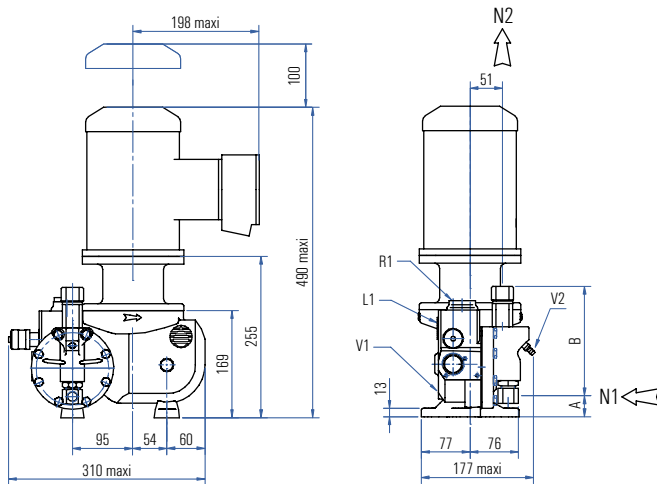

- N1: Suction
- N2: Discharge
- V2: Oil drain
- V1: Drain
- L1: Oil level
- R1: Oil fill

MODELS	DIMENSIONS	CONNECTIONS
5,5 l/h ⁽¹⁾ - 22 l/h 44 l/h - 66 l/h	A = 33 B = 173	Suction: 3/8" GAS F Discharge: 3/8" GAS F
2,6 l/h - 5,5 l/h ⁽²⁾ 10 l/h	A = 41 B = 163	Suction: 3/8" GAS F Discharge: 3/8" GAS F

⁽¹⁾ 5,5 l/h at 59 bar - ⁽²⁾ 5,5 l/h at 123 bar

Simplex version - Plastic liquid end

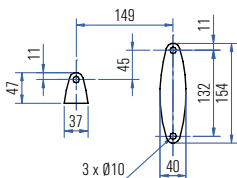
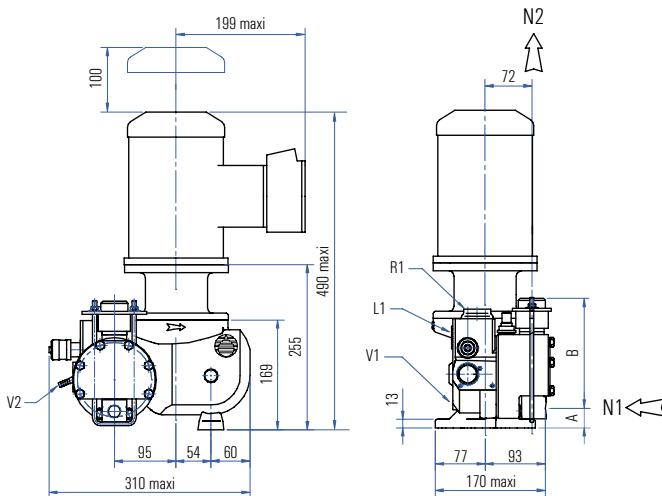

- N1: Suction
- N2: Discharge
- V2: Oil drain
- V1: Drain
- L1: Oil level
- R1: Oil fill

MODELS	DIMENSIONS	CONNECTIONS
22 l/h - 44 l/h 66 l/h	A = 28 B = 170	Suction: 1/2" GAS F Discharge: 3/8" GAS F
2,6 l/h - 5,5 l/h 10 l/h	A = 25 B = 177	Suction: 1/2" GAS F Discharge: 3/8" GAS F

Dimensions mROY XB (in mm)

Simplex version - Metallic liquid end

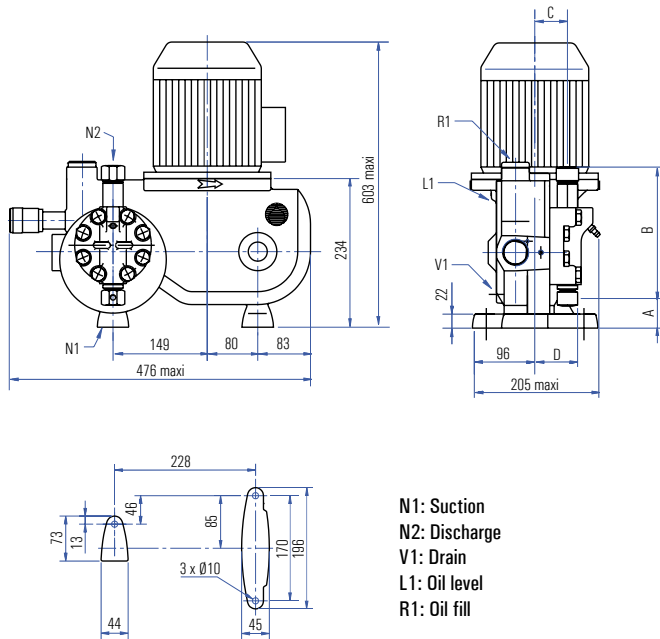

Simplex version - Plastic liquid end

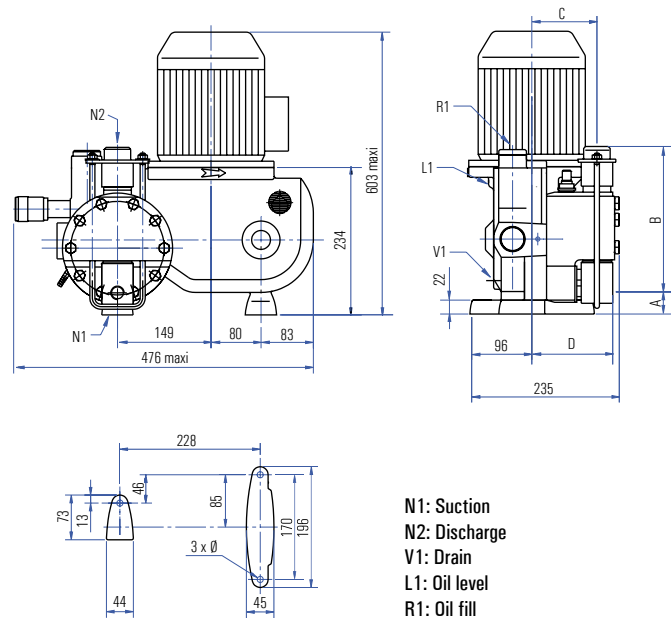

MODELS	DIMENSIONS	CONNECTIONS
30 l/h - 46 l/h 74 l/h - 80 l/h - 114 l/h 124 l/h - 200 l/h - 310 l/h	A = 22 B = 233 C = 56 D = 97	Suction: 1/2" GAS F Discharge: 3/8" GAS F
14 l/h - 21 l/h 34 l/h - 53 l/h	A = 47 B = 207 C = 52 D = 68	Suction: 3/8" GAS F Discharge: 3/8" GAS F

MODELS	DIMENSIONS	CONNECTIONS
30 l/h - 46 l/h 74 l/h - 80 l/h - 114 l/h 124 l/h - 200 l/h - 310 l/h	A = 35 B = 231 C = 104 D = 129	Suction: 1/2" GAS F Discharge: 3/8" GAS F

Protection

- As a standard pumps are protected with one coat of AMERON polyurethane paint of 100 microns, yellow RAL 1018
- Other treatment: consult us

Lubrication

- Ambient temperature from -5 °C to +90 °C:
Oil ISO - CC150 equivalent
- Temperature < -5 °C: consult us
- Quantity: 1 liter for XA and 3 liters for XB

Weight and packing

Models	Net weight (with oil)	Gross weight (with packing)	Packing ⁽¹⁾ (L x W x H)
mROY XA	approx. 25 kg	approx. 30 kg	355 x 355 x 575 mm
mROY XB	approx. 49 kg	approx. 58 kg	515 x 465 x 720 mm

⁽¹⁾ Standard cardboard packing



A network of over 100 distributors and sales and service offices.

To find your local representative, visit our website:

www.miltonroy-europe.com