

Submersible Motor Pump

Amarex

Sizes DN 50 to DN 150

Motors:

2 Poles: 014 to 084

4 Poles: 012 to 077

Type Series Booklet



Legal information/Copyright

Type Series Booklet Amarex

All rights reserved. The contents provided herein must neither be distributed, copied, reproduced, edited or processed for any other purpose, nor otherwise transmitted, published or made available to a third party without the manufacturer's express written consent.

Subject to technical modification without prior notice.

© KSB SE & Co. KGaA, Frankenthal 13/04/2020

Contents

Waste Water.....	5
Submersible Motor Pump.....	5
Amarex.....	5
Main applications.....	5
Fluids handled.....	5
Further information on fluids handled.....	5
Operating data.....	5
Design details.....	5
Designation.....	6
Materials.....	7
Product benefits.....	8
Product information.....	8
Product information as per Regulation No. 1907/2006 (REACH).....	8
Overview of product features / selection tables.....	9
Overview of product features, material variant G.....	9
Overview of product features, material variants G1, G2, GH.....	10
Impellers.....	10
Overview of fluids handled.....	11
Technical data.....	14
Amarex G, free-flow impeller, n = 2900 rpm.....	14
Amarex G, free-flow impeller, n = 1450 rpm.....	16
Selection charts.....	18
n = 2900 rpm.....	18
Amarex, F-max, n = 2900 rpm.....	18
Amarex, D-max, n = 2900 rpm.....	19
n = 1450 rpm.....	20
Amarex, F-max, n = 1450 rpm.....	20
Amarex, D-max, n = 1450 rpm.....	21
Dimensions and connections.....	22
Dimensions.....	22
Amarex DN 50/65/80/100/150, transportable version.....	22
Amarex DN 50, stationary installation, guide wire arrangement, single guide rail arrangement, guide hoop arrangement.....	29
Amarex DN 50, stationary installation, twin guide rail arrangement.....	31
Amarex DN 65, stationary installation, guide wire arrangement, single guide rail arrangement, guide hoop arrangement.....	33
Amarex DN 65, stationary installation, twin guide rail arrangement.....	36
Amarex DN 80, stationary installation, guide wire arrangement, twin guide rail arrangement.....	39
Amarex DN 80, stationary installation, single guide rail arrangement.....	44
Amarex DN 100, stationary installation, guide wire arrangement, twin guide rail arrangement.....	46
Amarex DN 100, stationary installation, single guide rail arrangement.....	50
Amarex DN 150, stationary installation, guide wire arrangement, twin guide rail arrangement.....	52
Connections.....	55
Installation types.....	56
Installation information.....	58
Suggested installation layouts for transportable pump sets.....	58
Suggested installation layouts for stationary pump sets.....	59
Suggested electrical installation layouts.....	60
Scope of supply.....	60
Accessories.....	61
Installation parts for stationary pump sets.....	61
Installation parts transportable pump sets.....	63
Chain for stationary and transportable pump sets.....	64
Pump accessories.....	64
Non-ATEX-compliant control units / switchgear.....	66
Alarm switchgears for pumps, non-ATEX-compliant.....	68
Accessories for non-ATEX-compliant control units.....	69
LevelControl Basic 2 control units, ATEX-compliant.....	70
Accessories for ATEX-compliant control units.....	72
General assembly drawings with list of components.....	73
General assembly drawings for version US.....	73
General assembly drawing for version YS.....	75

Glossary 77

Waste Water

Submersible Motor Pump

Amarex



Main applications

- Waste water transport
- Waste water management
- Drainage systems
- Waste water treatment plants
- Stormwater transport
- Recirculation
- Sludge treatment

Fluids handled

- Service water
- Grey water
- Waste water with faeces
- Waste water containing long fibres and solid substances
- Fluids containing gas
- Activated sludge
- Digested sludge
- Raw sludge

Further information on fluids handled

Overview of fluids handled (⇒ Page 11)

Operating data

Operating properties

Characteristic		Value
Flow rate	Q [m ³ /h]	≤ 320
	Q [l/s]	≤ 89
Head	H [m]	≤ 42
Fluid temperature	T [°C]	≤ +40
Motor rating	P ₂ [kW]	1,24- 8,4

Design details

Design

- Fully floodable submersible motor pump
- Not self-priming
- Close-coupled design

Drive

- Three-phase asynchronous squirrel-cage motor
- Type of protection Ex db IIB (applies to explosion-proof pump sets only)
- Enclosure: IP68 to EN 60529/IEC529

Shaft seal

- Two bi-directional mechanical seals in tandem arrangement, with liquid reservoir

Impeller type

- Various application-oriented impeller types

Bearings

Motor-end bearings:

- Grease-packed bearings sealed for life
- Maintenance-free

Pump-end bearings:

- Grease-packed bearings sealed for life
- Maintenance-free
- Reinforced bearings¹⁾

1) Standard for impeller type D-max, optional for impeller type F-max

Designation

Designation example

Position																																				
1	2	3	4	5	6	7	8	9	10	11	12	13	14	15	16	17	18	19	20	21	22	23	24	25	26	27	28	29	30	31	32	33	34	35	36	
A	R	X		D	1	0	0	-	2	3	0	/	0	6	5	F	4	U	S	G		-	2	2	0	/	0	0	0	0	0	0	X	1	0	0
See name plate and data sheet																								See data sheet												

Designation key

Position	Code	Description
1-3	Pump type	
	ARX	Amarex
5	Impeller type	
	D-max	Open two-vane impeller
	F-max	Free-flow impeller
6-12	Size	
	100	Nominal discharge nozzle diameter [mm]
	230	Hydraulic system size
14-16	Motor rating P _N [kW]	
	012	1,24

	084	8,40
17	Efficiency class ²⁾	
	C	IE3
	F	None
18	Number of motor poles	
	2	2 poles
	4	4 poles
19	Motor version	
	U	Without explosion protection, standard
	Y	Explosion-proof
20	Motor construction type	
	S	Wet installation
21-22	Material variant	
	G	Standard variant grey cast iron ³⁾
	G1	Standard variant grey cast iron, impeller made of duplex stainless steel
	G2	Standard variant grey cast iron, impeller made of white cast iron
	GH	Standard variant grey cast iron, impeller and discharge cover made of white cast iron
24-26	Nominal impeller diameter [mm]	
	090	90

	220	220
28-36	00000X100	Additional code for design variant

- 2) IEC 60034-30 standard not binding for submersible motor pumps. Efficiencies calculated/determined according to the measurement method specified in IEC 60034-2. The marking is used for submersible motors that achieve efficiency levels similar to those of standardised motors acc. to the IEC 60034-30 standard.
- 3) Depending on the configuration the impeller and suction cover of versions with D-max impeller are made of nodular cast iron.

Materials

Overview of available materials

Part No. (⇒ Page 73)	Description	Version	Material variant			
			G	G1 ⁴⁾	G2	GH
Pump set						
100	Casing		EN GJL-250			
160	Cover (motor)		EN GJL-250			
162	Suction cover	Standard	EN GJL-250			EN GJL-250 ⁴⁾
		With D-flector ⁵⁾	EN GJS-600-3	-	EN GJS-600-3	EN-GJN-HB555
163	Discharge cover		EN GJL-250			EN-GJN-HB555
210	Shaft		1.4021			
230	Impeller	F-max	EN GJL-250	1.4517	EN-GJN-HB555	EN-GJN-HB555
		D-max	EN GJS-600-3	-	EN-GJN-HB555	EN-GJN-HB555
412	O-ring	Standard	Nitrile butadiene rubber (NBR70)			
		Option	Fluoroelastomer (FKM80)			
			Viton, Teflon-coated (FEP/FKM)			
433	Mechanical seal	Drive end	Standard	Carbon/Al2O3		
		Pump end	Standard	SIC/SIC/NBR		
			Option	SIC/SIC/FPM		
			SIC/SIC/KAL			
914	Hexagon socket head cap screw		A4			
Installation parts						
182	Foot		1.4301			
572	Guide wire suspension bracket		1.4571			
59-24	Wire		1.4401			
72-1	Flanged bend		EN GJL-250			
732	Claw		EN GJL-250			
885	Lifting chain / lifting rope		Lifting chain: 1.4404			
			Lifting rope: polypropylene			
892	Foot plate		1.4301			
894	Mounting bracket		1.4301			

Description of materials
Grey cast iron EN-GJL-250 (lamellar graphite cast iron)

Lamellar graphite cast iron to EN 1561 is the most widely used cast material for handling municipal sewage, waste water and sludges as well as stormwater and surface water. It is suitable for neutral fluids which are only slightly aggressive and cause little wear. The pH should be ≥ 6.5 , the sand content ≤ 0.5 g/l.

Duplex stainless steel (1.4517 or technically equivalent material)

This type of carbon steel is resistant to cavitation, has excellent strength values and is used for high circumferential speeds. An excellent resistance to pitting corrosion makes ferritic-austenitic stainless carbon steel a popular choice for pumping acidic waste water with a high chloride content as well as seawater and brackish water. Thanks to its good chemical resistance, e.g. against waste water containing phosphorous and sulphuric acid, this material is used in a wide range of applications in the chemical industry and process engineering. Pumps made of duplex stainless steel have a very long service life, even when handling brines, chemical waste water (pH 1 - 12), grey water and landfill leachate.

Wear-resistant white cast iron (EN-GJN-HB555 [XCR14] or technically equivalent material)

Wear-resistant white cast iron is suitable for handling highly abrasive fluids containing sand, ash or iron ore sinter, for example. It has a Rockwell hardness of at least 54 HRC, which is higher than that of hardened chrome steel. Owing to its hardness, the chromium-molybdenum alloy cast iron features a notably higher wear resistance than EN-GJL-250 grey cast iron and other cast materials. The pH should be ≥ 6.5 .

4) Only available for version with F-max impeller
5) D-flector only available for version with D-max impeller

Product benefits

- High efficiency thanks to enhanced power density (Wh/m³), overall efficiency of up to 69 %, lower total cost of ownership
- Non-clogging (no clogging by wet wipes) with patented deflection technology and D-max impeller
- Long service life with high operating reliability and durable bearings (100,000 operating hours)
- Environmentally friendly with non-toxic, food-approved oil fill for lubricating the mechanical seal (liquid reservoir)
- Flexible thanks to easy substitution of competitor pumps with a large range of adapter claws and substitution pump app

Product information

Product information as per Regulation No. 1907/2006 (REACH)

For information as per chemicals Regulation (EC) No. 1907/2006 (REACH), see <http://www.ksb.com/reach>.

Overview of product features / selection tables
Overview of product features, material variant G

Overview of product features, material variant G

		Motor sizes			
		2 poles			
		14C 2...23F 2	18C 2...24F 2 29C 2...40F 2	35C 2...51F 2 ⁶⁾ 45C 2...73F 2	60C 2...84F 2
		4 poles			
		-	17F 4 12C 4...23F 4	21C4...35F 4 42F 4	36C 4...65F 4 45C 4...77F 4
Material variant		G			
Voltage		400 V			
Starting method		DOL	DOL	DOL DOL / star-delta	DOL / star-delta
Cooling		Cooled by surrounding fluid			
Duty cycle (see ²⁾ in outline drawing)		S1 - submerged (max. 25 m) S1 - outside the fluid, minimum water level R3 and power derating to IE3			
Frequency of starts/hour		30		30 (P ₂ ≤ 7,5 kW) 10 (P ₂ > 7,5 kW)	
Bearings					
Bearing design	D-max	-	Double-row angular contact ball bearing		
	F-max		Deep groove ball bearing		
Lubrication		Grease-packed rolling element bearings sealed for life			
Sealing element		Contacting seal on both sides (e.g. 2RS1)			
Monitoring					
Winding temperature motor version U		Temperature monitoring circuit (with automatic reset and start-up): bimetal switch directly connected with the control circuit of the motor contactor			
Winding temperature motor version Y		Limiting circuit (temperature limit for explosion protection without automatic reset): bimetal switch connected via a tripping unit with manual reset			
Power cable					
Type		Rubber-sheathed cable (H07RN8-F)			
Length	Motor version U	8 m			
	Motor version Y	10 m			
Cable entry	Motor version U	Cable gland			
	Motor version Y	Resin-sealed cable entry			
Sealing elements					
Shaft seal		Mechanical seal (bellows-type mechanical seal) (Q1Q1PGG)			
Elastomers		NBR			
Explosion protection					
Motor version U		Not explosion-proof			
Motor version Y		⊕ II 2G Ex db h IIB T4 Gb			
Coating		Environmentally friendly KSB top coat (two-component epoxy paint), colour RAL 5002, film thickness = 80 µm			
Maximum fluid temperature		40 °C			
Installation (⇒ Page 56)					
Stationary, with guide hoop	F-max	Installation depths 1.5 m/1.8 m/2.1 m			-
Stationary, with single guide rail		Installation depth: 6 m	-	-	-
Stationary, with twin guide rail		Installation depth: 6 m (available up to 12 m)			
Stationary, with guide wire		Installation depth: 4.5 m (available up to 9.5 m and 14.5 m)			
Transportable		Installation depth: 14.5 m			

2573.5/02-EN

- 6) Motors available only for DOL starting.
 7) Motors available only for DOL starting.
 8) 690 V DOL starting only
 9) 10 m / 15 m / 20 m / 30 m / 40 m / 50 m available

Overview of product features, material variants G1, G2, GH

Overview of product features, material variants G1, G2, GH

		Motor sizes			
		2 poles			
		14C 2...23F 2	18C 2...24F 2 29C 2...40F 2	35C 2...51F 2 ⁷⁾ 45C 2...73F 2	60C 2...84F 2
		4 poles			
		-	17F 4 12C 4...23F 4	21C 4...35F 4 42F 4	36C 4...65F 4 45C 4...77F 4
Material variant	D-max	G2, GH			
	F-max	G1, G2, GH			
Voltage		230 V / 380 V / 415 V / 500 V / 690 V			
Starting method		DOL	DOL	DOL DOL / star-delta ⁸⁾	DOL / star-delta ⁸⁾
Bearings					
Bearing design	F-max	Double-row angular contact ball bearing			
Power cable					
Type		Rubber-sheathed cable (S1BN8-F) Rubber-sheathed cable (S07RC4N8-F) (shielded) TEFZEL cable			
Length		≤ 50 m ⁹⁾			
Cable entry		Water-tight			
Monitoring					
Leakage inside the motor		Leakage sensor in the motor			
Sealing elements					
Shaft seal		Mechanical seal (bellows-type mechanical seal) Q1Q1PGG Mechanical seal with covered springs			
Material variant, shaft seal (pump end)		Q1Q1VGG Q12Q1VGG1 Q12Q1KGG1			
Elastomers		FKM FKM / Teflon			
Coating		Environmentally friendly KSB top coat (two-component epoxy paint), colour RAL 5002, film thickness = 80 µm			
Installation (⇒ Page 56)					
Stationary, with twin guide rail		Installation depth: 12 m			
Stationary, with guide wire		Installation depth: 14.5 m			

Impellers

	Free-flow impeller (impeller type F-max)	Suitable for the following fluids: fluids containing solids and stringy material as well as fluids with entrapped air or entrapped gas
	Open two-vane impeller (impeller type D-max)	Suitable for the following fluids: waste water containing wet wipes and long fibres

Overview of fluids handled
KSB EasySelect, selection software for all applications

KSB EasySelect is a comprehensive selection tool for all applications. It guides users to an optimal solution for their projects by offering a fast, easy and user-friendly way to select and configure pumps and valves. All that is required are some project-specific criteria and a few minutes' time. The tool systematically guides the user through KSB's wide range of products to the right product for the application at hand.

Other fluids upon request.

The table below for your guidance is based on KSB's long-standing experience. The data are standard values and are not to be considered as generally binding recommendations. More detailed advice is available from our specialist department. The KSB materials laboratory's wealth of experience may be useful when selecting materials.

Selection aid for materials and hydraulic systems per fluid

Fluid handled ¹⁰⁾	Recommended material	Recommended impeller type ¹¹⁾	Recommended sealing elements	Comments, further recommendations
Water, surface water				
▪ Dam water	G	F-max, D-max	NBR	Free passage > any solids contained, possibly pre-screened
▪ Lake water	G	F-max, D-max	NBR	Free passage > any solids contained, possibly pre-screened
▪ River water	G	F-max, D-max	NBR	Free passage > any solids contained, possibly pre-screened
Water, contaminated water				
▪ Mixed water, with strainer	G	F-max, D-max	NBR	-
▪ Mixed water, without strainer	G	F-max, D-max	NBR	-
▪ Slightly contaminated water	G	F-max, D-max	NBR	Free passage > any solids contained, possibly pre-screened
▪ Waste water with faeces	G	D-max, F-max	NBR	EN 12050, min. free passage of 40 mm
▪ Waste water without faeces	G	F-max, D-max	NBR	-
Municipal waste water				
▪ Biologically treated	G	F-max, D-max	NBR	-
▪ Containing air and gas	G	F-max	NBR	Up to 8 %; contact KSB for higher concentrations.
▪ Domestic waste water with faeces	G	F-max, D-max	NBR	EN 12050, min. free passage of 40 mm
▪ Domestic waste water without faeces	G	F-max, D-max	NBR	-
▪ Pumped drainage	G	F-max, D-max	NBR	-
▪ Raw waste water containing solids, long fibres and abrasive particles	G	F-max, D-max	NBR	Free passage > any solids contained, possibly pre-screened
▪ Untreated	G	F-max, D-max	NBR	ATV ¹²⁾ recommends a free passage of 100 mm; min. free passage: 76 mm
Abrasive municipal waste water				
▪ Raw waste water containing solids, long fibres and abrasive particles	GH	D-max, F-max		Solids content < 5 g/l
Water, raw water				
▪ No details specified	G	F-max, D-max	NBR	-
Corrosive and abrasive industrial waste water				
▪ No details specified	G1	F-max	NBR	-
Abrasive, non-corrosive industrial waste water¹³⁾				
▪ Containing dust / ash	G2, GH	F-max, D-max	NBR	-
▪ Containing lime milk > 5 to 15 %	G2, GH	F-max, D-max	NBR	-

10) For any fluids which are not listed in this table contact KSB.

11) The first impeller type listed should be given preference.

12) ATV = German regulatory body for waste water management

13) Severe hydroabrasive wear occurs if solids contents of approx. 0.5 g/l or higher are combined with circumferential speeds exceeding 20 m/s or part load conditions to the left of the duty point. The material variants required highly depend on the operating hours, rotational speed and flow velocity.

Fluid handled ¹⁰⁾	Recommended material	Recommended impeller type ¹¹⁾	Recommended sealing elements	Comments, further recommendations
▪ Pigment suspensions	G2, GH	F-max, D-max	NBR	-
▪ Lime water	G2, GH	F-max, D-max	NBR	-
▪ Wash water containing solids	G2, GH	F-max, D-max	NBR	-
Non-abrasive, non-corrosive industrial waste water¹⁴⁾				
▪ Industrial waste water with faeces	G	F-max, D-max	NBR	-
▪ Industrial waste water without faeces	G	F-max, D-max	NBR	-
▪ Containing aliphatic hydrocarbons	G	F-max	FKM	TEHSITE cable; for high concentrations contact KSB.
▪ Ammonium hydroxide	G	F-max	NBR	-
▪ Containing up to 5 % of ammonium hydroxide	G	F-max	NBR	-
▪ Containing aromatic hydrocarbons	G	F-max	FKM	TEHSITE cable; for high concentrations contact KSB.
▪ Containing benzene	G	F-max	FKM	TEHSITE cable; for high concentrations contact KSB.
▪ Containing 5 % of calcium hydroxide Ca(OH) ₂	G	F-max	NBR	-
▪ Containing chlorinated hydrocarbons	G	F-max	FKM	TEHSITE cable; for high concentrations contact KSB.
▪ Containing chloroform	G	F-max	FKM	TEHSITE cable; for high concentrations contact KSB.
▪ Containing 10 % of dissolved carbonate Na ₂ CO ₃	G	F-max	NBR	-
▪ Containing ethylene chloride	G	F-max	FEP-FKM	TEHSITE cable; for high concentrations contact KSB.
▪ Containing fibres	G	D-max, F-max	NBR	-
▪ Containing methane	G	F-max	FKM	TEHSITE cable; for high concentrations contact KSB.
▪ Containing methylene chloride	G	F-max	FEP-FKM	TEHSITE cable; for high concentrations contact KSB.
▪ Containing oil	G	F-max	FKM	TEHSITE cable; for high concentrations contact KSB.
▪ Containing paint suspension	G	F-max	NBR	Solvent-free, observe the operator's instructions.
▪ Containing petrol	G	F-max	FKM	TEHSITE cable; for high concentrations contact KSB.
▪ Containing 10 % of potassium hydroxide KOH	G	F-max	FEP-FKM	-
▪ Containing 5 % of sodium hydroxide NaOH	G	F-max	FEP-FKM	-
▪ Containing styrene	G	F-max	FEP-FKM	TEHSITE cable; for high concentrations contact KSB.
▪ Containing tetrachloroethylene	G	F-max	FKM	TEHSITE cable; for high concentrations contact KSB.
▪ Containing 25 % of urea (NH ₂) ₂ -CO	G	F-max	NBR	-
Acidic water				
▪ Slightly acidic, pH ≥ 6	G1	F-max	FKM	pH ≥ 6 G1 variant and FPM (Viton) O-rings
Suspensions containing solids				
▪ Pulp, concentration up to 1 % bone dry	G	F-max, D-max	NBR	-
▪ Water/sand mixture up to 5 g/l	G2, GH	F-max, D-max	NBR	-
▪ Pulp, concentration up to 6 % bone dry	G	F-max, D-max	NBR	-
▪ Water/sand mixture up to 0.5 g/l	G	F-max, D-max	NBR	-
Sludges				

14) The hydrocarbons mentioned may occur in very high concentrations due to the difference in specific weight and their low solubility. If this is the case, contact KSB.

Fluid handled ¹⁰⁾	Recommend ed material	Recommend ed impeller type ¹¹⁾	Recommend ed sealing elements	Comments, further recommendations
▪ Raw sludge	G	D-max, F-max	NBR	Pumpable up to a dry substance content of: 13 % (D-max), 8 % (F-max)
▪ Digested sludge	G	D-max, F-max	NBR	Pumpable up to a dry substance content of: 13 % (D-max), 8 % (F-max)
▪ Activated sludge	G	D-max, F-max	NBR	Pumpable up to a dry substance content of: 13 % (D-max), 8 % (F-max)

Technical data
Amarex G, free-flow impeller, n = 2900 rpm

G = material variant grey cast iron (pump casing) / grey cast iron (intermediate casing) / grey cast iron (impeller)

F = free-flow impeller

US = without explosion protection, for fluid temperatures of up to 40 °C

YS = explosion protection Ex II2G Ex db h IIB T4 Gb, for fluid temperatures of up to 40 °C

Amarex	Motor rating	Efficiency class	Number of poles	Motor version	Motor construction type	Material variant	Impeller diameter	P ₂	P ₁	I _N	I _A	T ¹⁵⁾	[kg]	Mat. No.
							[mm]	[kW]	[kW]	[A]	[A]	[°C]		
F050-140	23	F	2	U	S	G	100	2,35	3,04	5,25	45	40	56	39110001
F050-140	23	F	2	Y	S	G	100	2,35	3,04	5,25	45	40	58	39110002
F050-140	23	F	2	U	S	G	110	2,35	3,04	5,25	45	40	56	39110003
F050-140	23	F	2	Y	S	G	110	2,35	3,04	5,25	45	40	58	39110004
F050-140	23	F	2	U	S	G	120	2,35	3,04	5,25	45	40	56	39110005
F050-140	23	F	2	Y	S	G	120	2,35	3,04	5,25	45	40	59	39110006
F050-140	23	F	2	U	S	G	130	2,35	3,04	5,25	45	40	57	39110007
F050-140	23	F	2	Y	S	G	130	2,35	3,04	5,25	45	40	59	39110008
F050-140	23	F	2	U	S	G	140	2,35	3,04	5,25	45	40	57	39110009
F050-140	23	F	2	Y	S	G	140	2,35	3,04	5,25	45	40	59	39110010
F050-140	23	F	2	U	S	G	150	2,35	3,04	5,25	45	40	57	39110011
F050-140	23	F	2	Y	S	G	150	2,35	3,04	5,25	45	40	59	39110012
F050-140	23	F	2	U	S	G	160	2,35	3,04	5,25	45	40	57	39110013
F050-140	23	F	2	Y	S	G	160	2,35	3,04	5,25	45	40	59	39110014
F050-220	24	F	2	U	S	G	160	2,40	2,95	4,89	45	40	60	39110027
F050-220	24	F	2	Y	S	G	160	2,40	2,95	4,89	45	40	62	39110028
F050-220	40	F	2	U	S	G	160	4,00	4,86	8,17	76	40	63	39110031
F050-220	40	F	2	Y	S	G	160	4,00	4,86	8,17	76	40	66	39110032
F050-220	40	F	2	U	S	G	170	4,00	4,86	8,17	76	40	64	39110033
F050-220	40	F	2	Y	S	G	170	4,00	4,86	8,17	76	40	66	39110034
F050-220	40	F	2	U	S	G	180	4,00	4,86	8,17	76	40	64	39110045
F050-220	40	F	2	Y	S	G	180	4,00	4,86	8,17	76	40	66	39110046
F050-220	51	F	2	U	S	G	190	5,10	6,10	10,20	86	40	83	39110035
F050-220	51	F	2	Y	S	G	190	5,10	6,10	10,20	86	40	86	39110036
F050-220	51	F	2	U	S	G	170	5,10	6,10	10,20	86	40	82	39110037
F050-220	51	F	2	Y	S	G	170	5,10	6,10	10,20	86	40	86	39110038
F050-220	51	F	2	U	S	G	180	5,10	6,10	10,20	86	40	83	39110039
F050-220	51	F	2	Y	S	G	180	5,10	6,10	10,20	86	40	86	39110040
F050-220	73	F	2	U	S	G	190	7,30	8,72	14,70	125	40	87	39110041
F050-220	73	F	2	Y	S	G	190	7,30	8,72	14,70	125	40	90	39110042
F065-170	24	F	2	U	S	G	110	2,40	2,95	4,89	45	40	66	39110077
F065-170	24	F	2	Y	S	G	110	2,40	2,95	4,89	45	40	65	39110078
F065-170	24	F	2	U	S	G	120	2,40	2,95	4,89	45	40	63	39110079
F065-170	24	F	2	Y	S	G	120	2,40	2,95	4,89	45	40	65	39110080
F065-170	24	F	2	U	S	G	130	2,40	2,95	4,89	45	40	63	39110081
F065-170	24	F	2	Y	S	G	130	2,40	2,95	4,89	45	40	65	39110082
F065-170	24	F	2	U	S	G	140	2,40	2,95	4,89	45	40	63	39110083
F065-170	24	F	2	Y	S	G	140	2,40	2,95	4,89	45	40	65	39110084
F065-170	40	F	2	U	S	G	150	4,00	4,86	8,17	76	40	67	39110085
F065-170	40	F	2	Y	S	G	150	4,00	4,86	8,17	76	40	69	39110086
F065-170	40	F	2	U	S	G	160	4,00	4,86	8,17	76	40	67	39110087
F065-170	40	F	2	Y	S	G	160	4,00	4,86	8,17	76	40	69	39110088
F065-170	40	F	2	U	S	G	170	4,00	4,86	8,17	76	40	67	39110089
F065-170	40	F	2	Y	S	G	170	4,00	4,86	8,17	76	40	70	39110090

15) Fluid temperature

Amarex	Motor rating	Efficiency class	Number of poles	Motor version	Motor construction type	Material variant	Impeller diameter	P ₂	P ₁	I _N	I _A	T ⁽¹⁵⁾	[kg]	Mat. No.
							[mm]	[kW]	[kW]	[A]	[A]	[°C]		
F065-170	40	F	2	U	S	G	180	4,00	4,86	8,17	76	40	68	39110097
F065-170	40	F	2	Y	S	G	180	4,00	4,86	8,17	76	40	70	39110098
F065-170	51	F	2	U	S	G	180	5,10	6,10	10,20	86	40	85	39110091
F065-170	51	F	2	Y	S	G	180	5,10	6,10	10,20	86	40	89	39110092
F065-170	73	F	2	U	S	G	190	7,30	8,72	14,70	125	40	89	39110093
F065-170	73	F	2	Y	S	G	190	7,30	8,72	14,70	125	40	93	39110094
F080-220	24	F	2	U	S	G	140	2,40	2,95	4,89	45	40	67	39110163
F080-220	24	F	2	Y	S	G	140	2,40	2,95	4,89	45	40	69	39110164
F080-220	40	F	2	U	S	G	150	4,00	4,86	8,17	76	40	71	39110165
F080-220	40	F	2	Y	S	G	150	4,00	4,86	8,17	76	40	73	39110166
F080-220	40	F	2	U	S	G	160	4,00	4,86	8,17	76	40	71	39110167
F080-220	40	F	2	Y	S	G	160	4,00	4,86	8,17	76	40	73	39110168
F080-220	40	F	2	U	S	G	170	4,00	4,86	8,17	76	40	71	39110183
F080-220	40	F	2	Y	S	G	170	4,00	4,86	8,17	76	40	74	39110184
F080-220	51	F	2	U	S	G	170	5,10	6,10	10,20	86	40	86	39110169
F080-220	51	F	2	Y	S	G	170	5,10	6,10	10,20	86	40	90	39110170
F080-220	73	F	2	U	S	G	180	7,30	8,72	14,70	125	40	89	39110171
F080-220	73	F	2	Y	S	G	180	7,30	8,72	14,70	125	40	93	39110172
F080-220	73	F	2	U	S	G	190	7,30	8,72	14,70	125	40	90	39110173
F080-220	73	F	2	Y	S	G	190	7,30	8,72	14,70	125	40	93	39110174
F080-220	84	F	2	U	S	G	200	8,40	9,85	16,80	156	40	99	39110175
F080-220	84	F	2	Y	S	G	200	8,40	9,85	16,80	156	40	103	39110176

Amarex G, free-flow impeller, n = 1450 rpm

G = material variant grey cast iron (pump casing) / grey cast iron (intermediate casing) / grey cast iron (impeller)

F = free-flow impeller

US = without explosion protection, for fluid temperatures of up to 40 °C

YS = explosion protection Ex II2G Ex db h IIB T4 Gb, for fluid temperatures of up to 40 °C

Amarex	Motor rating	Efficiency class	Number of poles	Motor version	Motor construction type	Material variant	Impeller diameter	P ₂	P ₁	I _N	I _A	T ¹⁶⁾	[kg]	Mat. No.
							[mm]	[kW]	[kW]	[A]	[A]	[°C]		
F065-150	17	F	4	U	S	G	150	1,67	2,13	3,71	27	40	64	39110055
F065-150	17	F	4	Y	S	G	150	1,67	2,13	3,71	27	40	66	39110056
F065-150	17	F	4	U	S	G	160	1,67	2,13	3,71	27	40	64	39110057
F065-150	17	F	4	Y	S	G	160	1,67	2,13	3,71	27	40	66	39110058
F065-150	17	F	4	U	S	G	170	1,67	2,13	3,71	27	40	64	39110059
F065-150	17	F	4	Y	S	G	170	1,67	2,13	3,71	27	40	66	39110060
F065-150	17	F	4	U	S	G	180	1,67	2,13	3,71	27	40	64	39110061
F065-150	17	F	4	Y	S	G	180	1,67	2,13	3,71	27	40	67	39110062
F065-150	17	F	4	U	S	G	190	1,67	2,13	3,71	27	40	65	39110063
F065-150	17	F	4	Y	S	G	190	1,67	2,13	3,71	27	40	67	39110064
F065-150	17	F	4	U	S	G	200	1,67	2,13	3,71	27	40	65	39110065
F065-150	17	F	4	Y	S	G	200	1,67	2,13	3,71	27	40	67	39110066
F065-230	17	F	4	U	S	G	160	1,67	2,13	3,71	27	40	65	39110107
F065-230	17	F	4	Y	S	G	160	1,67	2,13	3,71	27	40	67	39110108
F065-230	17	F	4	U	S	G	170	1,67	2,13	3,71	27	40	65	39110109
F065-230	17	F	4	Y	S	G	170	1,67	2,13	3,71	27	40	67	39110110
F065-230	17	F	4	U	S	G	180	1,67	2,13	3,71	27	40	65	39110111
F065-230	17	F	4	Y	S	G	180	1,67	2,13	3,71	27	40	67	39110112
F065-230	17	F	4	U	S	G	190	1,67	2,13	3,71	27	40	66	39110113
F065-230	17	F	4	Y	S	G	190	1,67	2,13	3,71	27	40	68	39110114
F065-230	23	F	4	U	S	G	200	2,30	2,98	5,15	38	40	66	39110115
F065-230	23	F	4	Y	S	G	200	2,30	2,98	5,15	38	40	68	39110116
F065-230	35	F	4	U	S	G	210	3,55	4,41	7,56	45	40	80	39110117
F065-230	35	F	4	Y	S	G	210	3,55	4,41	7,56	45	40	84	39110118
F080-150	17	F	4	U	S	G	140	1,67	2,13	3,71	27	40	67	39110129
F080-150	17	F	4	Y	S	G	140	1,67	2,13	3,71	27	40	70	39110130
F080-150	17	F	4	U	S	G	160	1,67	2,13	3,71	27	40	68	39110131
F080-150	17	F	4	Y	S	G	160	1,67	2,13	3,71	27	40	70	39110132
F080-180	17	F	4	U	S	G	140	1,67	2,13	3,71	27	40	72	39110143
F080-180	17	F	4	Y	S	G	140	1,67	2,13	3,71	27	40	74	39110144
F080-180	17	F	4	U	S	G	150	1,67	2,13	3,71	27	40	72	39110145
F080-180	17	F	4	Y	S	G	150	1,67	2,13	3,71	27	40	74	39110146
F080-180	17	F	4	U	S	G	160	1,67	2,13	3,71	27	40	72	39110147
F080-180	17	F	4	Y	S	G	160	1,67	2,13	3,71	27	40	74	39110148
F080-180	17	F	4	U	S	G	170	1,67	2,13	3,71	27	40	72	39110149
F080-180	17	F	4	Y	S	G	170	1,67	2,13	3,71	27	40	74	39110150
F080-180	17	F	4	U	S	G	180	1,67	2,13	3,71	27	40	73	39110151
F080-180	17	F	4	Y	S	G	180	1,67	2,13	3,71	27	40	75	39110152
F080-230	17	F	4	U	S	G	150	1,67	2,13	3,71	27	40	68	39110193
F080-230	17	F	4	Y	S	G	150	1,67	2,13	3,71	27	40	70	39110194
F080-230	17	F	4	U	S	G	160	1,67	2,13	3,71	27	40	69	39110195
F080-230	17	F	4	Y	S	G	160	1,67	2,13	3,71	27	40	71	39110196
F080-230	23	F	4	U	S	G	170	2,30	2,98	5,15	38	40	71	39110197
F080-230	23	F	4	Y	S	G	170	2,30	2,98	5,15	38	40	73	39110198
F080-230	35	F	4	U	S	G	180	3,55	4,41	7,56	45	40	89	39110199
F080-230	35	F	4	Y	S	G	180	3,55	4,41	7,56	45	40	93	39110200

16) Fluid temperature

Amarex	Motor rating	Efficiency class	Number of poles	Motor version	Motor construction type	Material variant	Impeller diameter	P ₂	P ₁	I _N	I _A	T ⁽¹⁶⁾	[kg]	Mat. No.
							[mm]	[kW]	[kW]	[A]	[A]	[°C]		
F080-230	35	F	4	U	S	G	190	3,55	4,41	7,56	45	40	90	39110201
F080-230	35	F	4	Y	S	G	190	3,55	4,41	7,56	45	40	93	39110202
F080-230	42	F	4	U	S	G	200	4,15	5,40	10,50	81	40	96	39110203
F080-230	42	F	4	Y	S	G	200	4,15	5,40	10,50	81	40	100	39110204
F080-230	42	F	4	U	S	G	210	4,15	5,40	10,50	81	40	96	39110205
F080-230	42	F	4	Y	S	G	210	4,15	5,40	10,50	81	40	100	39110206
F100-180	17	F	4	U	S	G	140	1,67	2,13	3,71	27	40	70	39110221
F100-180	17	F	4	Y	S	G	140	1,67	2,13	3,71	27	40	72	39110222
F100-180	17	F	4	U	S	G	160	1,67	2,13	3,71	27	40	70	39110223
F100-180	17	F	4	Y	S	G	160	1,67	2,13	3,71	27	40	73	39110224
F100-180	17	F	4	U	S	G	180	1,67	2,13	3,71	27	40	71	39110225
F100-180	17	F	4	Y	S	G	180	1,67	2,13	3,71	27	40	73	39110226
F100-180	17	F	4	U	S	G	190	1,67	2,13	3,71	27	40	71	39110227
F100-180	17	F	4	Y	S	G	190	1,67	2,13	3,71	27	40	74	39110228
F100-230	17	F	4	U	S	G	160	1,67	2,13	3,71	27	40	71	39110259
F100-230	17	F	4	Y	S	G	160	1,67	2,13	3,71	27	40	73	39110260
F100-230	23	F	4	U	S	G	170	2,30	2,98	5,15	38	40	73	39110261
F100-230	23	F	4	Y	S	G	170	2,30	2,98	5,15	38	40	75	39110262
F100-230	35	F	4	U	S	G	180	3,55	4,41	7,56	45	40	92	39110263
F100-230	35	F	4	Y	S	G	180	3,55	4,41	7,56	45	40	96	39110264
F100-230	35	F	4	U	S	G	190	3,55	4,41	7,56	45	40	93	39110265
F100-230	35	F	4	Y	S	G	190	3,55	4,41	7,56	45	40	96	39110266
F100-230	42	F	4	U	S	G	200	4,15	5,40	10,50	81	40	99	39110267
F100-230	42	F	4	Y	S	G	200	4,15	5,40	10,50	81	40	103	39110268
F100-230	42	F	4	U	S	G	210	4,15	5,40	10,50	81	40	99	39110269
F100-230	42	F	4	Y	S	G	210	4,15	5,40	10,50	81	40	103	39110270
F150-180	65	F	4	U	S	G	160	6,50	7,89	13,40	106	40	124	39110285
F150-180	65	F	4	Y	S	G	160	6,50	7,89	13,40	106	40	128	39110286
F150-180	65	F	4	U	S	G	170	6,50	7,89	13,40	106	40	124	39110287
F150-180	65	F	4	Y	S	G	170	6,50	7,89	13,40	106	40	128	39110288
F150-180	65	F	4	U	S	G	180	6,50	7,89	13,40	106	40	125	39110289
F150-180	65	F	4	Y	S	G	180	6,50	7,89	13,40	106	40	128	39110290
F150-230	65	F	4	U	S	G	170	6,50	7,89	13,40	106	40	125	39110301
F150-230	65	F	4	Y	S	G	170	6,50	7,89	13,40	106	40	129	39110302
F150-230	65	F	4	U	S	G	180	6,50	7,89	13,40	106	40	126	39110303
F150-230	65	F	4	Y	S	G	180	6,50	7,89	13,40	106	40	129	39110304
F150-230	65	F	4	U	S	G	190	6,50	7,89	13,40	106	40	126	39110305
F150-230	65	F	4	Y	S	G	190	6,50	7,89	13,40	106	40	130	39110306
F150-230	65	F	4	U	S	G	200	6,50	7,89	13,40	106	40	127	39110307
F150-230	65	F	4	Y	S	G	200	6,50	7,89	13,40	106	40	130	39110308
F150-230	65	F	4	U	S	G	210	6,50	7,89	13,40	106	40	127	39110309
F150-230	65	F	4	Y	S	G	210	6,50	7,89	13,40	106	40	131	39110310
F150-230	77	F	4	U	S	G	220	7,70	9,20	15,90	118	40	132	39110311
F150-230	77	F	4	Y	S	G	220	7,70	9,20	15,90	118	40	136	39110312

Selection charts

n = 2900 rpm

Amarex, F-max, n = 2900 rpm

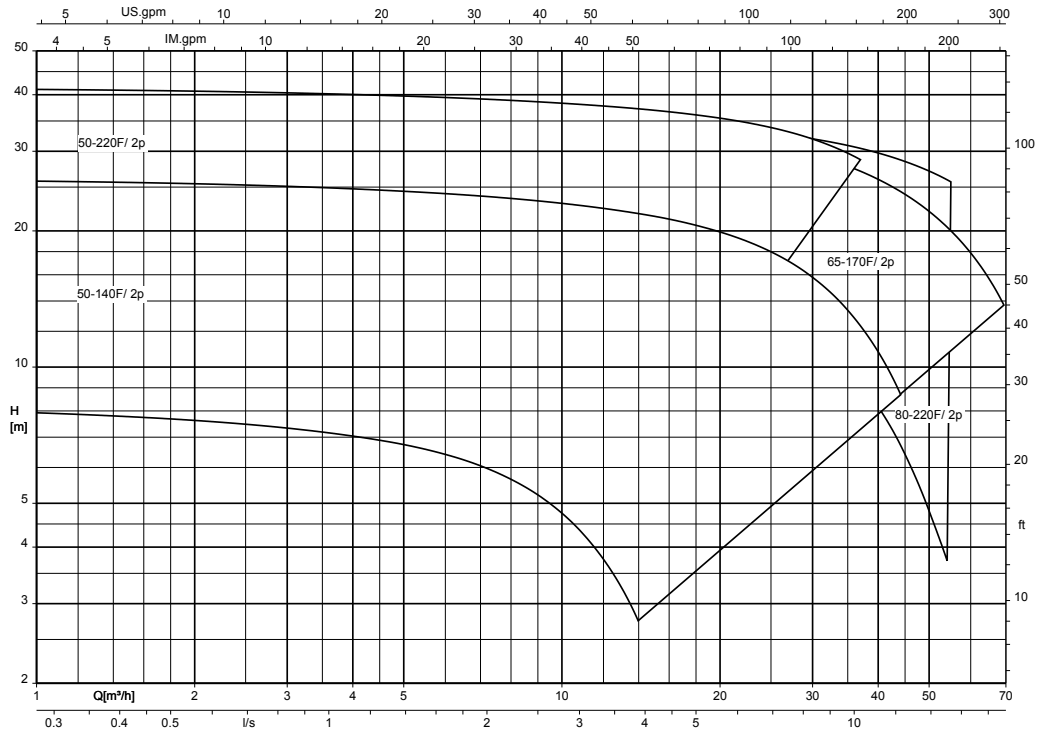

Amarex, D-max, n = 2900 rpm

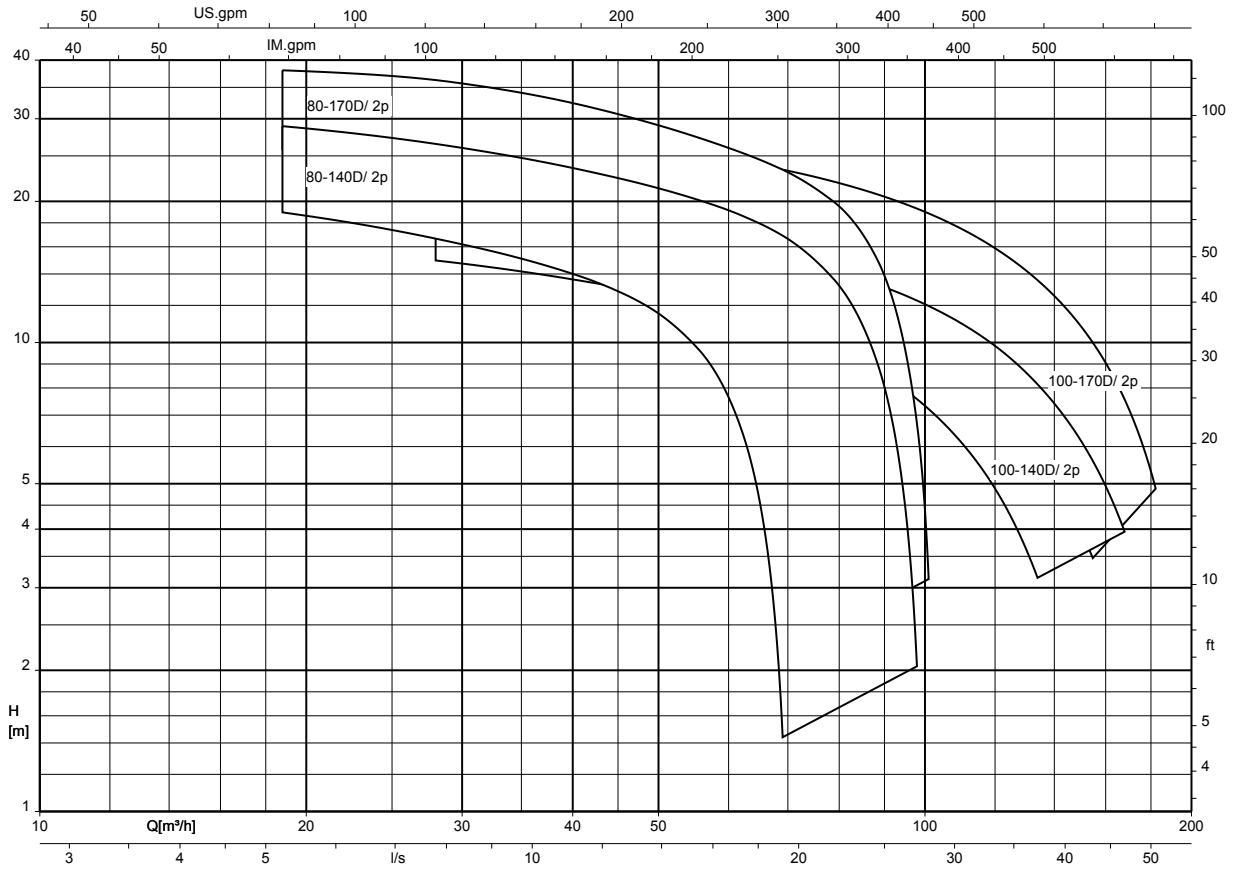

n = 1450 rpm

Amarex, F-max, n = 1450 rpm

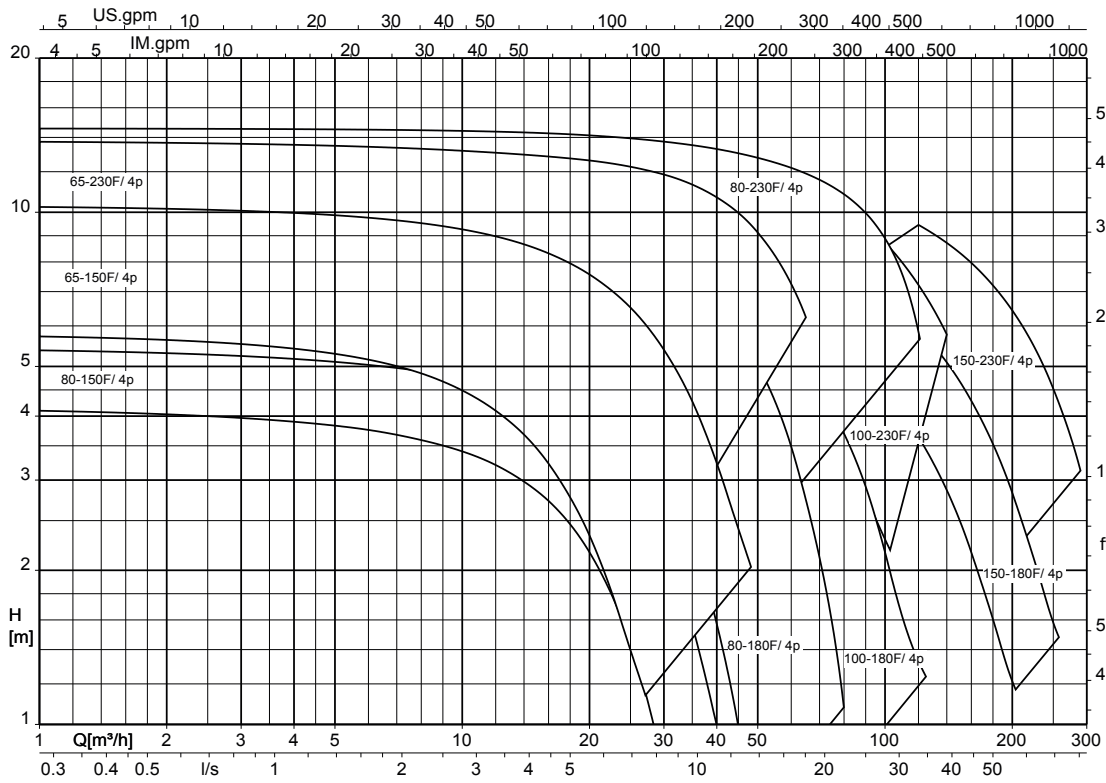

Amarex, D-max, n = 1450 rpm

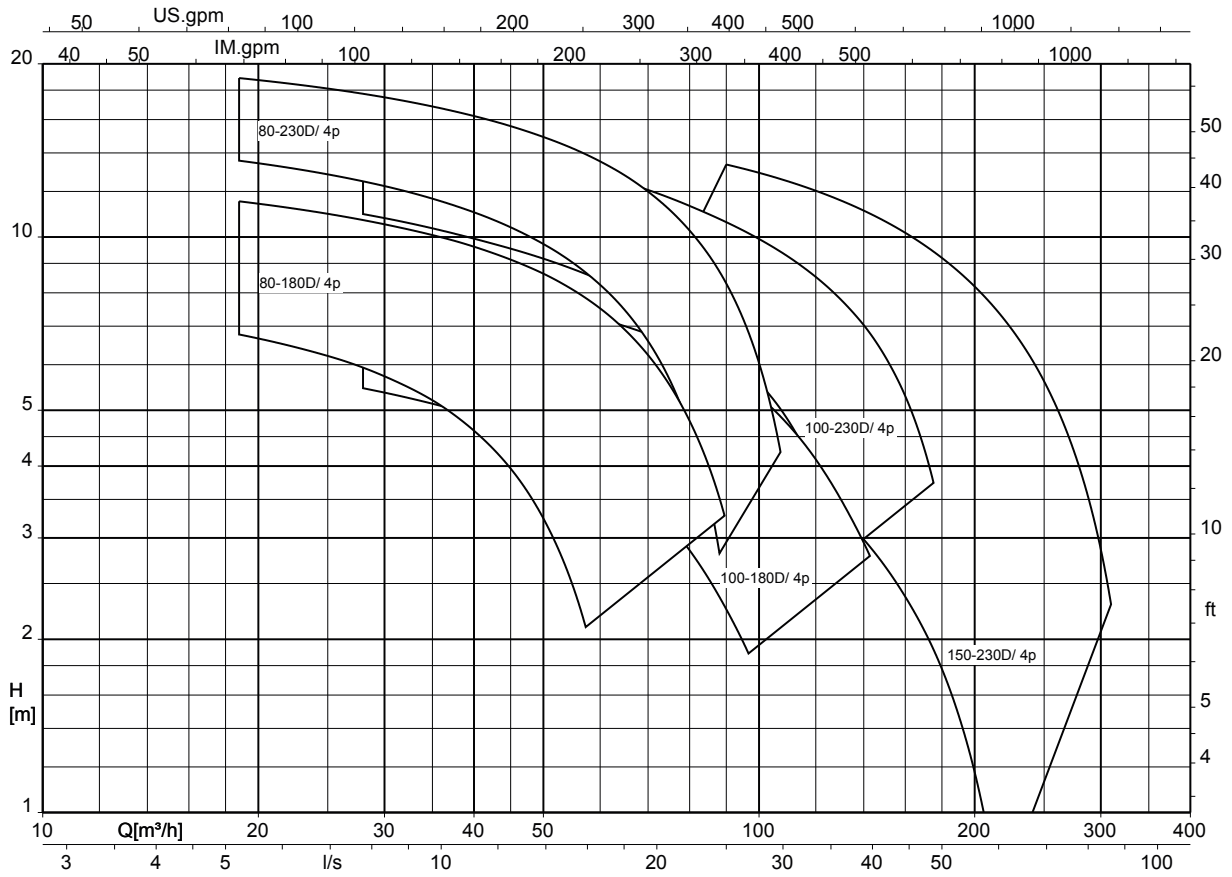

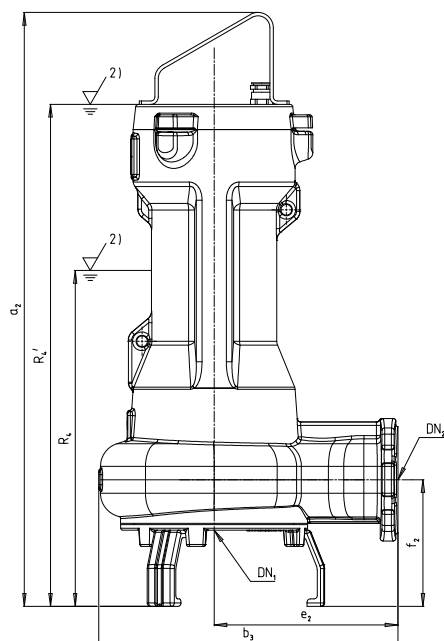
Dimensions and connections
Dimensions
Amarex DN 50/65/80/100/150, transportable version

Fig. 1: Dimensions of transportable model

2)	Minimum submergence for continuous operation
----	--

Pump dimensions [mm]

Amarex	Motor rating	Efficiency class	Number of poles	Motor version	Motor version	DN ₁	DN ₂	a ₂	b ₃	e ₂	f ₂	R ₄	R ₄ '
F050-140	014	C	2	U	S	50	50	715	279	170	163	345	-
F050-140	014	C	2	Y	S	50	50	724	279	170	163	354	-
F050-140	023	F	2	U	S	50	50	715	279	170	163	-	600
F050-140	023	F	2	Y	S	50	50	724	279	170	163	-	609
F050-220	018	C	2	U	S	50	50	753	311	180	163	378	-
F050-220	018	C	2	Y	S	50	50	762	311	180	163	387	-
F050-220	024	F	2	U	S	50	50	753	311	180	163	-	638
F050-220	024	F	2	Y	S	50	50	762	311	180	163	-	647
F050-220	029	C	2	U	S	50	50	753	311	180	163	423	-
F050-220	029	C	2	Y	S	50	50	762	311	180	163	432	-
F050-220	035	C	2	U	S	50	50	826	311	180	163	381	-
F050-220	035	C	2	Y	S	50	50	835	311	180	163	390	-
F050-220	040	F	2	U	S	50	50	753	311	180	163	-	638
F050-220	040	F	2	Y	S	50	50	762	311	180	163	-	647
F050-220	045	C	2	U	S	50	50	826	311	180	163	381	-
F050-220	045	C	2	Y	S	50	50	835	311	180	163	390	-
F050-220	051	F	2	U	S	50	50	826	311	180	163	-	691
F050-220	051	F	2	Y	S	50	50	835	311	180	163	-	700
F050-220	073	F	2	U	S	50	50	826	311	180	163	-	691
F050-220	073	F	2	Y	S	50	50	835	311	180	163	-	700
F065-150	017	F	4	U	S	65	65	784	351	210	184	-	669
F065-150	017	F	4	Y	S	65	65	793	351	210	184	-	678
F065-150	021	C	4	U	S	65	65	856	351	210	184	391	-
F065-150	021	C	4	Y	S	65	65	865	351	210	184	400	-
F065-150	035	F	4	U	S	65	65	856	351	210	184	-	721
F065-150	035	F	4	Y	S	65	65	865	351	210	184	-	730

Amarex	Motor rating	Efficiency class	Number of poles	Motor version	Motor version	DN ₁	DN ₂	a ₂	b ₃	e ₂	f ₂	R ₄	R ₄ '
F065-170	018	C	2	U	S	65	65	784	351	210	184	369	-
F065-170	018	C	2	Y	S	65	65	793	351	210	184	378	-
F065-170	024	F	2	U	S	65	65	784	351	210	184	-	669
F065-170	024	F	2	Y	S	65	65	793	351	210	184	-	678
F065-170	029	C	2	U	S	65	65	784	351	210	184	454	-
F065-170	029	C	2	Y	S	65	65	793	351	210	184	463	-
F065-170	035	C	2	U	S	65	65	856	351	210	184	391	-
F065-170	035	C	2	Y	S	65	65	865	351	210	184	400	-
F065-170	040	F	2	U	S	65	65	784	351	210	184	-	669
F065-170	040	F	2	Y	S	65	65	793	351	210	184	-	678
F065-170	045	C	2	U	S	65	65	856	351	210	184	411	-
F065-170	045	C	2	Y	S	65	65	865	351	210	184	420	-
F065-170	051	F	2	U	S	65	65	856	351	210	184	-	721
F065-170	051	F	2	Y	S	65	65	865	351	210	184	-	730
F065-170	073	F	2	U	S	65	65	856	351	210	184	-	721
F065-170	073	F	2	Y	S	65	65	865	351	210	184	-	730
F065-230	012	C	2	U	S	65	65	784	351	210	184	369	-
F065-230	012	C	2	Y	S	65	65	793	351	210	184	378	-
F065-230	017	F	4	U	S	65	65	784	351	210	184	-	669
F065-230	017	F	4	Y	S	65	65	793	351	210	184	-	678
F065-230	021	C	4	U	S	65	65	856	351	210	184	358	-
F065-230	021	C	4	Y	S	65	65	865	351	210	184	367	-
F065-230	023	F	4	U	S	65	65	784	351	210	184	-	669
F065-230	023	F	4	Y	S	65	65	793	351	210	184	-	678
F065-230	035	F	4	U	S	65	65	856	351	210	184	-	721
F065-230	035	F	4	Y	S	65	65	865	351	210	184	-	730
F065-230	042	F	4	U	S	65	65	856	351	210	184	-	721
F065-230	042	F	4	Y	S	65	65	865	351	210	184	-	730
D080-140	018	C	2	U	S	80	80	758	373	230	176	343	-
D080-140	018	C	2	Y	S	80	80	767	373	230	176	352	-
D080-140	024	F	2	U	S	80	80	758	373	230	176	-	643
D080-140	024	F	2	Y	S	80	80	767	373	230	176	-	652
D080-140	029	C	2	U	S	80	80	758	373	230	176	428	-
D080-140	029	C	2	Y	S	80	80	767	373	230	176	437	-
D080-140	035	C	2	U	S	80	80	786	373	230	176	321	-
D080-140	035	C	2	Y	S	80	80	795	373	230	176	330	-
D080-140	040	F	2	U	S	80	80	758	373	230	176	-	643
D080-140	040	F	2	Y	S	80	80	767	373	230	176	-	652
D080-140	051	F	2	U	S	80	80	786	373	230	176	-	651
D080-140	051	F	2	Y	S	80	80	795	373	230	176	-	660
F080-150	017	F	4	U	S	80	80	798	385	230	194	-	683
F080-150	017	F	4	Y	S	80	80	807	385	230	194	-	692
F080-150	021	C	4	U	S	80	80	871	384	230	182	406	-
F080-150	021	C	4	Y	S	80	80	880	384	230	182	415	-
F080-150	035	F	4	U	S	80	80	871	384	230	182	-	736
F080-150	035	F	4	Y	S	80	80	880	384	230	182	-	745
D080-170	035	C	2	U	S	80	80	837	390	230	182	372	-
D080-170	035	C	2	Y	S	80	80	846	390	230	182	381	-
D080-170	045	C	2	U	S	80	80	837	390	230	182	392	-
D080-170	045	C	2	Y	S	80	80	846	390	230	182	401	-
D080-170	051	F	2	U	S	80	80	837	390	230	182	-	702
D080-170	051	F	2	Y	S	80	80	846	390	230	182	-	711
D080-170	060	C	2	U	S	80	80	857	390	230	182	432	-
D080-170	060	C	2	Y	S	80	80	866	390	230	182	441	-
D080-170	073	F	2	U	S	80	80	837	390	230	182	-	702
D080-170	073	F	2	Y	S	80	80	846	390	230	182	-	711
D080-170	084	F	2	U	S	80	80	857	390	230	182	-	722

Amarex	Motor rating	Efficiency class	Number of poles	Motor version	Motor version	DN ₁	DN ₂	a ₂	b ₃	e ₂	f ₂	R ₄	R ₄ '
D080-170	084	F	2	Y	S	80	80	866	390	230	182	-	731
D080-180	017	F	2	U	S	90	80	758	373	230	176	-	643
D080-180	017	F	2	Y	S	90	80	767	373	230	176	-	652
D080-180	021	C	4	U	S	90	80	786	373	230	176	321	-
D080-180	021	C	4	Y	S	90	80	795	373	230	176	330	-
D080-180	035	F	4	U	S	90	80	786	373	230	176	-	651
D080-180	035	F	4	Y	S	90	80	795	373	230	176	-	660
F080-180	017	F	4	U	S	80	80	798	385	230	194	-	683
F080-180	017	F	4	Y	S	80	80	807	385	230	194	-	692
F080-180	021	C	4	U	S	80	80	871	384	230	182	406	-
F080-180	021	C	4	Y	S	80	80	880	384	230	182	415	-
F080-180	035	F	4	U	S	80	80	871	384	230	182	-	736
F080-180	035	F	4	Y	S	80	80	880	384	230	182	-	745
F080-220	018	C	2	U	S	80	80	798	385	230	194	383	-
F080-220	018	C	2	Y	S	80	80	807	385	230	194	392	-
F080-220	024	F	2	U	S	80	80	798	385	230	194	-	683
F080-220	024	F	2	Y	S	80	80	807	385	230	194	-	692
F080-220	029	C	2	U	S	80	80	798	385	230	194	468	-
F080-220	029	C	2	Y	S	80	80	807	385	230	194	477	-
F080-220	035	C	2	U	S	80	80	871	384	230	182	406	-
F080-220	035	C	2	Y	S	80	80	880	384	230	182	415	-
F080-220	040	F	2	U	S	80	80	798	385	230	194	-	683
F080-220	040	F	2	Y	S	80	80	807	385	230	194	-	692
F080-220	045	C	2	U	S	80	80	871	384	230	182	426	-
F080-220	045	C	2	Y	S	80	80	880	384	230	182	435	-
F080-220	051	F	2	U	S	80	80	871	384	230	182	-	736
F080-220	051	F	2	Y	S	80	80	880	384	230	182	-	745
F080-220	060	C	2	U	S	80	80	891	384	230	194	466	-
F080-220	060	C	2	Y	S	80	80	900	384	230	194	475	-
F080-220	073	F	2	U	S	80	80	871	384	230	182	-	736
F080-220	073	F	2	Y	S	80	80	880	384	230	182	-	745
F080-220	084	F	2	U	S	80	80	891	384	230	194	-	756
F080-220	084	F	2	Y	S	80	80	900	384	230	194	-	765
D080-230	021	C	4	U	S	90	80	837	390	230	182	372	-
D080-230	021	C	4	Y	S	90	80	846	390	230	182	381	-
D080-230	035	F	4	U	S	90	80	837	390	230	182	-	702
D080-230	035	F	4	Y	S	90	80	846	390	230	182	-	711
D080-230	036	C	4	U	S	90	80	857	390	230	182	372	-
D080-230	036	C	4	Y	S	90	80	866	390	230	182	381	-
D080-230	042	F	4	U	S	90	80	837	390	230	182	-	702
D080-230	042	F	4	Y	S	90	80	846	390	230	182	-	711
D080-230	065	F	4	U	S	90	80	857	390	230	182	-	722
D080-230	065	F	4	Y	S	90	80	866	390	230	182	-	731
F080-230	012	C	2	U	S	80	80	798	385	230	194	383	-
F080-230	012	C	2	Y	S	80	80	807	385	230	194	392	-
F080-230	017	F	4	U	S	80	80	798	385	230	194	-	683
F080-230	017	F	4	Y	S	80	80	807	385	230	194	-	692
F080-230	021	C	4	U	S	80	80	871	384	230	182	406	-
F080-230	021	C	4	Y	S	80	80	880	384	230	182	415	-
F080-230	023	F	4	U	S	80	80	798	385	230	194	-	683
F080-230	023	F	4	Y	S	80	80	807	385	230	194	-	692
F080-230	035	F	4	U	S	80	80	871	384	230	182	-	736
F080-230	035	F	4	Y	S	80	80	880	384	230	182	-	745
F080-230	036	C	4	U	S	80	80	891	384	230	194	406	-
F080-230	036	C	4	Y	S	80	80	900	384	230	194	415	-
F080-230	042	F	4	U	S	80	80	871	384	230	182	-	736
F080-230	042	F	4	Y	S	80	80	880	384	230	182	-	745

Amarex	Motor rating	Efficiency class	Number of poles	Motor version	Motor version	DN ₁	DN ₂	a ₂	b ₃	e ₂	f ₂	R ₄	R ₄ '
F080-230	045	C	4	U	S	80	80	891	384	230	194	486	-
F080-230	045	C	4	Y	S	80	80	900	384	230	194	495	-
F080-230	065	F	4	U	S	80	80	891	384	230	194	-	756
F080-230	065	F	4	Y	S	80	80	900	384	230	194	-	765
F080-230	077	F	4	U	S	80	80	891	384	230	194	-	756
F080-230	077	F	4	Y	S	80	80	900	384	230	194	-	765
D100-140	029	C	2	U	S	90	100	784	431	270	193	454	-
D100-140	029	C	2	Y	S	90	100	793	431	270	193	463	-
D100-140	035	C	2	U	S	90	100	812	431	270	193	347	-
D100-140	035	C	2	Y	S	90	100	821	431	270	193	356	-
D100-140	040	F	2	U	S	90	100	784	431	270	193	-	669
D100-140	040	F	2	Y	S	90	100	793	431	270	193	-	678
D100-140	051	F	2	U	S	90	100	812	431	270	193	-	677
D100-140	051	F	2	Y	S	90	100	821	431	270	193	-	686
D100-170	035	C	2	U	S	90	100	844	440	270	186	379	-
D100-170	035	C	2	Y	S	90	100	853	440	270	186	388	-
D100-170	045	C	2	U	S	90	100	844	440	270	186	399	-
D100-170	045	C	2	Y	S	90	100	853	440	270	186	408	-
D100-170	051	F	2	U	S	90	100	844	440	270	186	-	709
D100-170	051	F	2	Y	S	90	100	853	440	270	186	-	718
D100-170	060	C	2	U	S	90	100	864	440	270	186	439	-
D100-170	060	C	2	Y	S	90	100	873	440	270	186	448	-
D100-170	073	F	2	U	S	90	100	844	440	270	186	-	709
D100-170	073	F	2	Y	S	90	100	853	440	270	186	-	718
D100-170	084	F	2	U	S	90	100	864	440	270	186	-	729
D100-170	084	F	2	Y	S	90	100	873	440	270	186	-	738
D100-180	017	F	4	U	S	110	100	784	431	270	193	-	669
D100-180	017	F	4	Y	S	110	100	793	431	270	193	-	678
D100-180	021	C	4	U	S	110	100	812	431	270	193	347	-
D100-180	021	C	4	Y	S	110	100	821	431	270	193	356	-
D100-180	035	F	4	U	S	110	100	812	431	270	193	-	677
D100-180	035	F	4	Y	S	110	100	821	431	270	193	-	686
F100-180	017	F	4	U	S	100	100	821	433	270	207	-	706
F100-180	017	F	4	Y	S	100	100	830	433	270	207	-	715
F100-180	021	C	4	U	S	100	100	894	433	270	207	429	-
F100-180	021	C	4	Y	S	100	100	903	433	270	207	438	-
F100-180	035	F	4	U	S	100	100	894	433	270	207	-	759
F100-180	035	F	4	Y	S	100	100	903	433	270	207	-	768
D100-230	021	C	4	U	S	110	100	844	440	270	186	379	-
D100-230	021	C	4	Y	S	110	100	853	440	270	186	388	-
D100-230	035	F	4	U	S	110	100	844	440	270	186	-	709
D100-230	035	F	4	Y	S	110	100	853	440	270	186	-	718
D100-230	036	C	4	U	S	110	100	864	440	270	186	379	-
D100-230	036	C	4	Y	S	110	100	873	440	270	186	388	-
D100-230	042	F	4	U	S	110	100	844	440	270	186	-	709
D100-230	042	F	4	Y	S	110	100	853	440	270	186	-	718
D100-230	065	F	4	U	S	110	100	864	440	270	186	-	729
D100-230	065	F	4	Y	S	110	100	873	440	270	186	-	738
F100-230	012	C	2	U	S	100	100	821	433	270	207	406	-
F100-230	012	C	2	Y	S	100	100	830	433	270	207	415	-
F100-230	017	F	4	U	S	100	100	821	433	270	207	-	706
F100-230	017	F	4	Y	S	100	100	830	433	270	207	-	715
F100-230	021	C	4	U	S	100	100	894	433	270	207	429	-
F100-230	021	C	4	Y	S	100	100	903	433	270	207	438	-
F100-230	023	F	4	U	S	100	100	821	433	270	207	-	706
F100-230	023	F	4	Y	S	100	100	830	433	270	207	-	715
F100-230	035	F	4	U	S	100	100	894	433	270	207	-	759

Amarex	Motor rating	Efficiency class	Number of poles	Motor version	Motor version	DN ₁	DN ₂	a ₂	b ₃	e ₂	f ₂	R ₄	R ₄ '
F100-230	035	F	4	Y	S	100	100	903	433	270	207	-	768
F100-230	036	C	4	U	S	100	100	914	433	270	207	429	-
F100-230	036	C	4	Y	S	100	100	923	433	270	207	438	-
F100-230	042	F	4	U	S	100	100	894	433	270	207	-	759
F100-230	042	F	4	Y	S	100	100	903	433	270	207	-	768
F100-230	045	C	4	U	S	100	100	914	433	270	207	509	-
F100-230	045	C	4	Y	S	100	100	923	433	270	207	518	-
F100-230	065	F	4	U	S	100	100	914	433	270	207	-	779
F100-230	065	F	4	Y	S	100	100	923	433	270	207	-	788
F100-230	077	F	4	U	S	100	100	914	433	270	207	-	779
F100-230	077	F	4	Y	S	100	100	923	433	270	207	-	788
F150-180	036	C	4	U	S	150	150	926	512	320	217	441	-
F150-180	036	C	4	Y	S	150	150	935	512	320	217	450	-
F150-180	065	F	4	U	S	150	150	926	512	320	217	-	791
F150-180	065	F	4	Y	S	150	150	935	512	320	217	-	800
D150-230	036	C	4	U	S	150	150	926	512	320	217	441	-
D150-230	036	C	4	Y	S	150	150	935	512	320	217	450	-
D150-230	045	C	4	U	S	150	150	926	512	320	217	521	-
D150-230	045	C	4	Y	S	150	150	935	512	320	217	530	-
D150-230	065	F	4	U	S	150	150	926	512	320	217	-	791
D150-230	065	F	4	Y	S	150	150	935	512	320	217	-	800
D150-230	077	F	4	U	S	150	150	926	512	320	217	-	791
D150-230	077	F	4	Y	S	150	150	935	512	320	217	-	800
F150-230	036	C	4	U	S	150	150	926	512	320	217	441	-
F150-230	036	C	4	Y	S	150	150	935	512	320	217	450	-
F150-230	045	C	4	U	S	150	150	926	512	320	217	521	-
F150-230	045	C	4	Y	S	150	150	935	512	320	217	530	-
F150-230	065	F	4	U	S	150	150	926	512	320	217	-	791
F150-230	065	F	4	Y	S	150	150	935	512	320	217	-	800
F150-230	077	F	4	U	S	150	150	926	512	320	217	-	791
F150-230	077	F	4	Y	S	150	150	935	512	320	217	-	800

Connection elbow

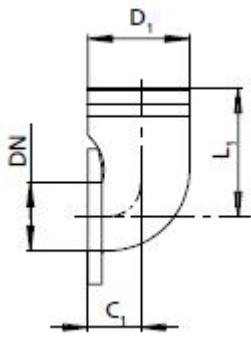

Connection elbow with flange/hose connection (P13)

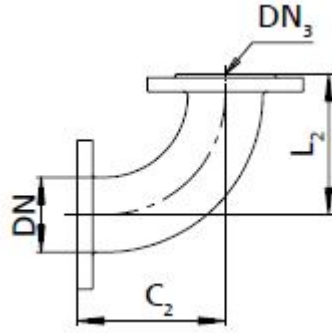

Connection elbow with flanges (P14)

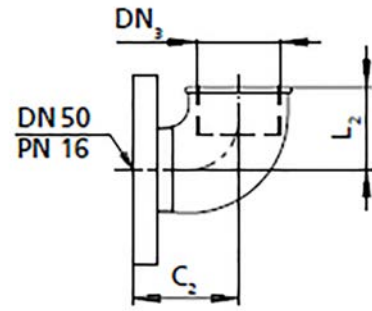

Connection elbow with internal thread and external thread (P14) and threaded flange (P27)

Dimensions of connection elbow [mm]

DN	Connection elbow with flange/hose connection (P13)			Connection elbow with flanges (P14)			Connection elbow with internal thread and external thread (P14) and threaded flange (P27)		
	D ₁	C ₁	L ₁	DN ₃	C ₂	L ₂	DN ₃	C ₂	L ₂
50	-	-	-	-	-	-	G 2"	78	58
65	75	40	135	65	135	135	-	-	-
80	75	115	175	80	135	135	-	-	-
100	110	45	195	100	120	135	-	-	-

Pump flange DN2

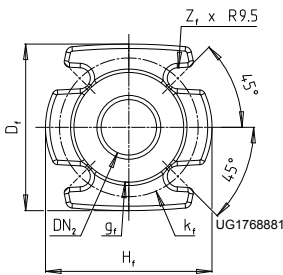

Pump flange DN 50 / 65

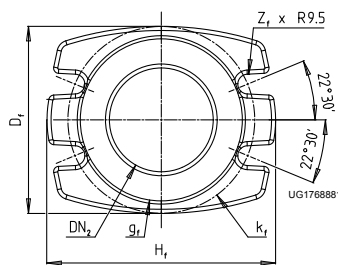

Pump flange DN 80 / 100

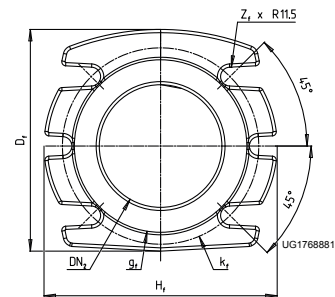

Pump flange DN 150

Dimensions of pump flange DN2 [mm]

Flange variant	DN ₂	g _f	k _f	D _f	H _f	Z _f
50	50	99	125	150	150	4
65	65	118	145	170	170	4
80	80	132	160	160	200	4
100	100	156	180	1180	220	4
150	100	211	240	271	285	6

Pump flange DN3

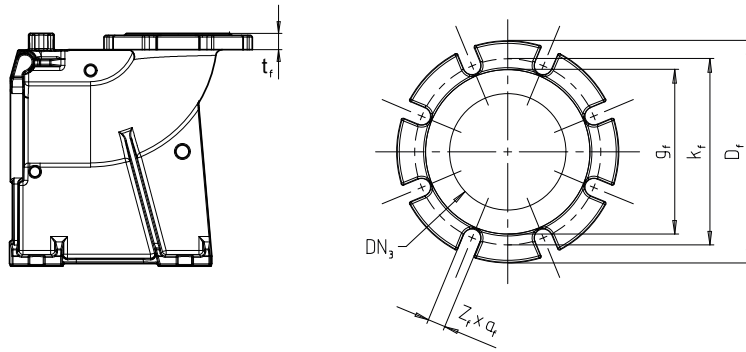

Fig. 2: Dimensions of pump flange DN3

Dimensions of pump flange DN3 [mm]

Flange variant	DN ₂	g _f	k _f	t _f	D _f	Z _f	a _f ¹⁷⁾
DN 50/50 ISO	50	102	160	20	125	4	18+2
DN 50/50 ASME	50	102	160	20	120,5	4	18+2
DN 65/65	65	122	140	22	140	4	21
DN 65/80 ISO	80	133	160	27	200	8	18
DN 65/80 ASME	80	127	152	26,5	191	4	19
DN 80/80 ISO	80	132	160	23	200	8	18
DN 80/80 ASME	80	127	152	23	190	4	19
DN 80/100	100	156	180	23	220	8	18
DN 100/100	100	156	180	24	200	8	19
DN 150/150	150	212	240	26	285	8	23

17) Number of holes

Amarex DN 50, stationary installation, guide wire arrangement, single guide rail arrangement, guide hoop arrangement

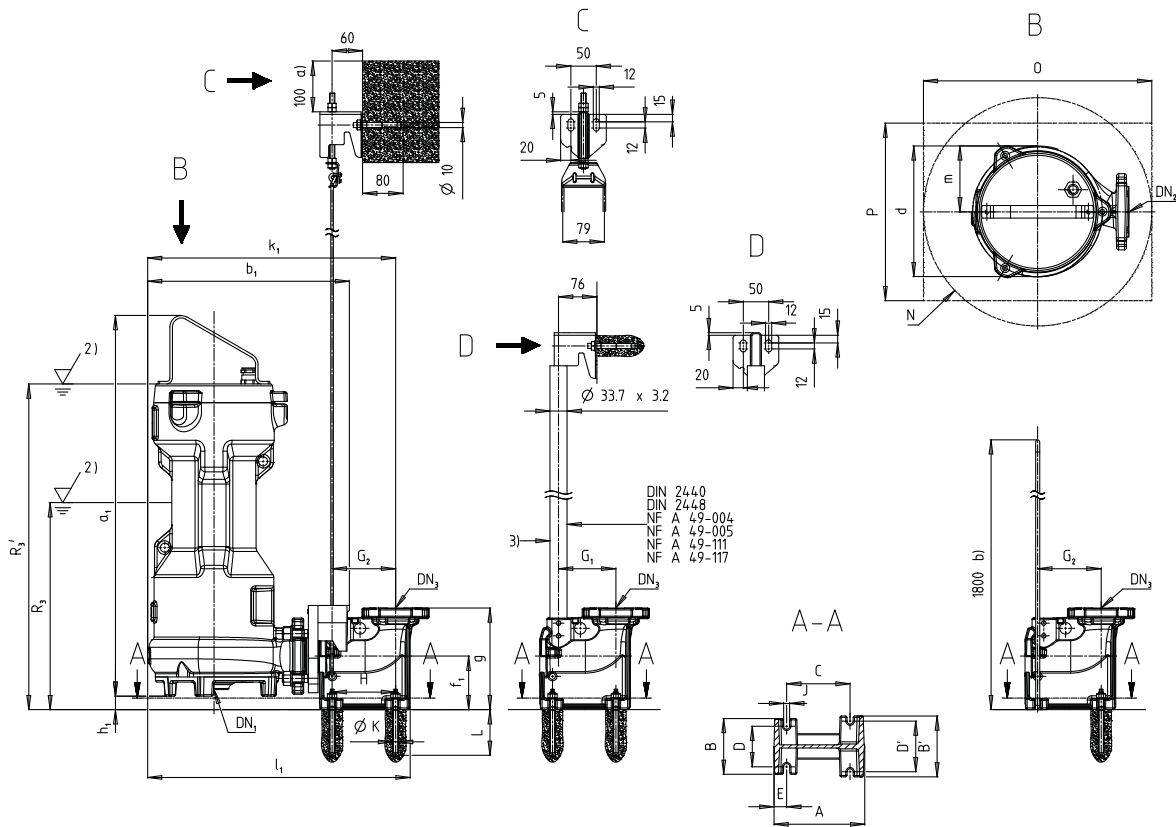

Fig. 3: Dimensions for stationary installation, guide wire arrangement, single guide rail arrangement, guide hoop arrangement

2)	Minimum submergence for continuous operation
3)	Not included in KSB's scope of supply

Pump set dimensions [mm]

Amarex	Motor rating	Efficiency class	Number of poles	Motor version	Motor construction type	DN ₁	DN ₂	a ₁	b ₁	d	D _f	f ₁	g	g _f	h ₁	H _f	k ₁	k _f	l ₁	m	Z _f	R3	R3'
F050-140	014	C	2	U	S	42	50	631	368	216	150	106	201	99	27	150	457	125	486	109	4	288	-
F050-140	014	C	2	Y	S	42	50	640	368	216	150	106	201	99	27	150	457	125	486	109	4	297	-
F050-140	023	F	2	U	S	42	50	631	368	216	150	106	201	99	27	150	457	125	486	109	4	-	543
F050-140	023	F	2	Y	S	42	50	640	368	216	150	106	201	99	27	150	457	125	486	109	4	-	552
F050-220	018	C	2	U	S	42	50	669	398	258	150	106	201	99	27	150	489	125	518	130	4	321	-
F050-220	018	C	2	Y	S	42	50	678	398	258	150	106	201	99	27	150	489	125	518	130	4	330	-
F050-220	024	F	2	U	S	42	50	669	398	258	150	106	201	99	27	150	489	125	518	130	4	-	581
F050-220	024	F	2	Y	S	42	50	678	398	258	150	106	201	99	27	150	489	125	518	130	4	-	590
F050-220	029	C	2	U	S	42	50	669	398	258	150	106	201	99	27	150	489	125	518	130	4	366	-
F050-220	029	C	2	Y	S	42	50	678	398	258	150	106	201	99	27	150	489	125	518	130	4	375	-
F050-220	035	C	2	U	S	42	50	742	398	258	150	106	201	99	27	150	489	125	518	130	4	324	-
F050-220	035	C	2	Y	S	42	50	751	398	258	150	106	201	99	27	150	489	125	518	130	4	333	-
F050-220	040	F	2	U	S	42	50	669	398	258	150	106	201	99	27	150	489	125	518	130	4	-	590
F050-220	040	F	2	Y	S	42	50	678	398	258	150	106	201	99	27	150	489	125	518	130	4	-	590
F050-220	045	C	2	U	S	42	50	742	398	258	150	106	201	99	27	150	489	125	518	130	4	324	-
F050-220	045	C	2	Y	S	42	50	751	398	258	150	106	201	99	27	150	489	125	518	130	4	333	-
F050-220	051	F	2	U	S	42	50	742	398	258	150	106	201	99	27	150	489	125	518	130	4	-	634

Amarex	Motor rating	Efficiency class	Number of poles	Motor version	Motor construction type	DN ₁	DN ₂	a ₁	b ₁	d	D _f	f ₁	g	g _f	h ₁	H _f	k ₁	k _f	l ₁	m	Z _f	R3	R3'
F050-220	051	F	2	Y	S	42	50	751	398	258	150	106	201	99	27	150	489	125	518	130	4	-	643
F050-220	073	F	2	U	S	42	50	742	398	258	150	106	201	99	27	150	489	125	518	130	4	-	643
F050-220	073	F	2	Y	S	42	50	751	398	258	150	106	201	99	27	150	489	125	518	130	4	-	570

Foundation dimensions [mm]

Amarex	Motor rating	Efficiency class	Number of poles	Motor version	Motor construction type	DN ₃	A	B	B'	C	D	D'	E	G ₁	G ₂	H	J	ØK	L	N min.	O min.	P min.
F050-140	014	C	2	U	S	50	179	110	120	125	80	100	25	113	125	125	12	10	90	465	465	350
F050-140	014	C	2	Y	S	50	179	110	120	125	80	100	25	113	125	125	12	10	90	465	465	350
F050-140	023	F	2	U	S	50	179	110	120	125	80	100	25	113	125	125	12	10	90	465	465	350
F050-140	023	F	2	Y	S	50	179	110	120	125	80	100	25	113	125	125	12	10	90	465	465	350
F050-220	018	C	2	U	S	50	179	110	120	125	80	100	25	113	125	125	12	10	90	465	465	350
F050-220	018	C	2	Y	S	50	179	110	120	125	80	100	25	113	125	125	12	10	90	465	465	350
F050-220	024	F	2	U	S	50	179	110	120	125	80	100	25	113	125	125	12	10	90	465	465	350
F050-220	024	F	2	Y	S	50	179	110	120	125	80	100	25	113	125	125	12	10	90	465	465	350
F050-220	029	C	2	U	S	50	179	110	120	125	80	100	25	113	125	125	12	10	90	465	465	350
F050-220	029	C	2	Y	S	50	179	110	120	125	80	100	25	113	125	125	12	10	90	465	465	350
F050-220	035	C	2	U	S	50	179	110	120	125	80	100	25	-	125	125	12	10	90	465	465	350
F050-220	035	C	2	Y	S	50	179	110	120	125	80	100	25	-	125	125	12	10	90	465	465	350
F050-220	040	F	2	U	S	50	179	110	120	125	80	100	25	113	125	125	12	10	90	465	465	350
F050-220	040	F	2	Y	S	50	179	110	120	125	80	100	25	113	125	125	12	10	90	465	465	350
F050-220	045	C	2	U	S	50	179	110	120	125	80	100	25	-	125	125	12	10	90	465	465	350
F050-220	045	C	2	Y	S	50	179	110	120	125	80	100	25	-	125	125	12	10	90	465	465	350
F050-220	051	F	2	U	S	50	179	110	120	125	80	100	25	-	125	125	12	10	90	465	465	350
F050-220	051	F	2	Y	S	50	179	110	120	125	80	100	25	-	125	125	12	10	90	465	465	350
F050-220	073	F	2	U	S	50	179	110	120	125	80	100	25	-	125	125	12	10	90	465	465	350
F050-220	073	F	2	Y	S	50	179	110	120	125	80	100	25	-	125	125	12	10	90	465	465	350

Amarex	Motor rating	Efficiency class	Number of poles	Motor version	Motor construction type	DN ₁	DN ₂	a ₁	b ₁	d	D _f	f ₁	g	g _f	h ₁	H _f	k ₁	k _f	l ₁	m	Z _f	R3	R3'
F050-220	051	F	2	Y	S	42	50	751	400	258	150	106	201	99	27	150	489	125	518	130	4	-	643
F050-220	073	F	2	U	S	42	50	742	400	258	150	106	201	99	27	150	489	125	518	130	4	-	643
F050-220	073	F	2	Y	S	42	50	751	400	258	150	106	201	99	27	150	489	125	518	130	4	-	570

Foundation dimensions [mm]

Amarex	Motor rating	Efficiency class	Number of poles	Motor version	Motor construction type	DN ₃	A	B	B'	C	D	D'	E	G ₁	G ₂	H	J	ØK	L	N min.	O min.	P min.
F050-140	014	C	2	U	S	50	179	110	120	125	80	100	25	113	-	125	12	10	90	465	465	350
F050-140	014	C	2	Y	S	50	179	110	120	125	80	100	25	113	-	125	12	10	90	465	465	350
F050-140	023	F	2	U	S	50	179	110	120	125	80	100	25	113	-	125	12	10	90	465	465	350
F050-140	023	F	2	Y	S	50	179	110	120	125	80	100	25	113	-	125	12	10	90	465	465	350
F050-220	018	C	2	U	S	50	179	110	120	125	80	100	25	113	-	125	12	10	90	465	465	350
F050-220	018	C	2	Y	S	50	179	110	120	125	80	100	25	113	-	125	12	10	90	465	465	350
F050-220	024	F	2	U	S	50	179	110	120	125	80	100	25	113	-	125	12	10	90	465	465	350
F050-220	024	F	2	Y	S	50	179	110	120	125	80	100	25	113	-	125	12	10	90	465	465	350
F050-220	029	C	2	U	S	50	179	110	120	125	80	100	25	113	-	125	12	10	90	465	465	350
F050-220	029	C	2	Y	S	50	179	110	120	125	80	100	25	113	-	125	12	10	90	465	465	350
F050-220	035	C	2	U	S	50	179	110	120	125	80	100	25	113	-	125	12	10	90	465	465	350
F050-220	035	C	2	Y	S	50	179	110	120	125	80	100	25	113	-	125	12	10	90	465	465	350
F050-220	040	F	2	U	S	50	179	110	120	125	80	100	25	113	-	125	12	10	90	465	465	350
F050-220	040	F	2	Y	S	50	179	110	120	125	80	100	25	113	-	125	12	10	90	465	465	350
F050-220	045	C	2	U	S	50	179	110	120	125	80	100	25	113	-	125	12	10	90	465	465	350
F050-220	045	C	2	Y	S	50	179	110	120	125	80	100	25	113	-	125	12	10	90	465	465	350
F050-220	051	F	2	U	S	50	179	110	120	125	80	100	25	113	-	125	12	10	90	465	465	350
F050-220	051	F	2	Y	S	50	179	110	120	125	80	100	25	113	-	125	12	10	90	465	465	350
F050-220	073	F	2	U	S	50	179	110	120	125	80	100	25	113	-	125	12	10	90	465	465	350
F050-220	073	F	2	Y	S	50	179	110	120	125	80	100	25	113	-	125	12	10	90	465	465	350

Amarex DN 65, stationary installation, guide wire arrangement, single guide rail arrangement, guide hoop arrangement

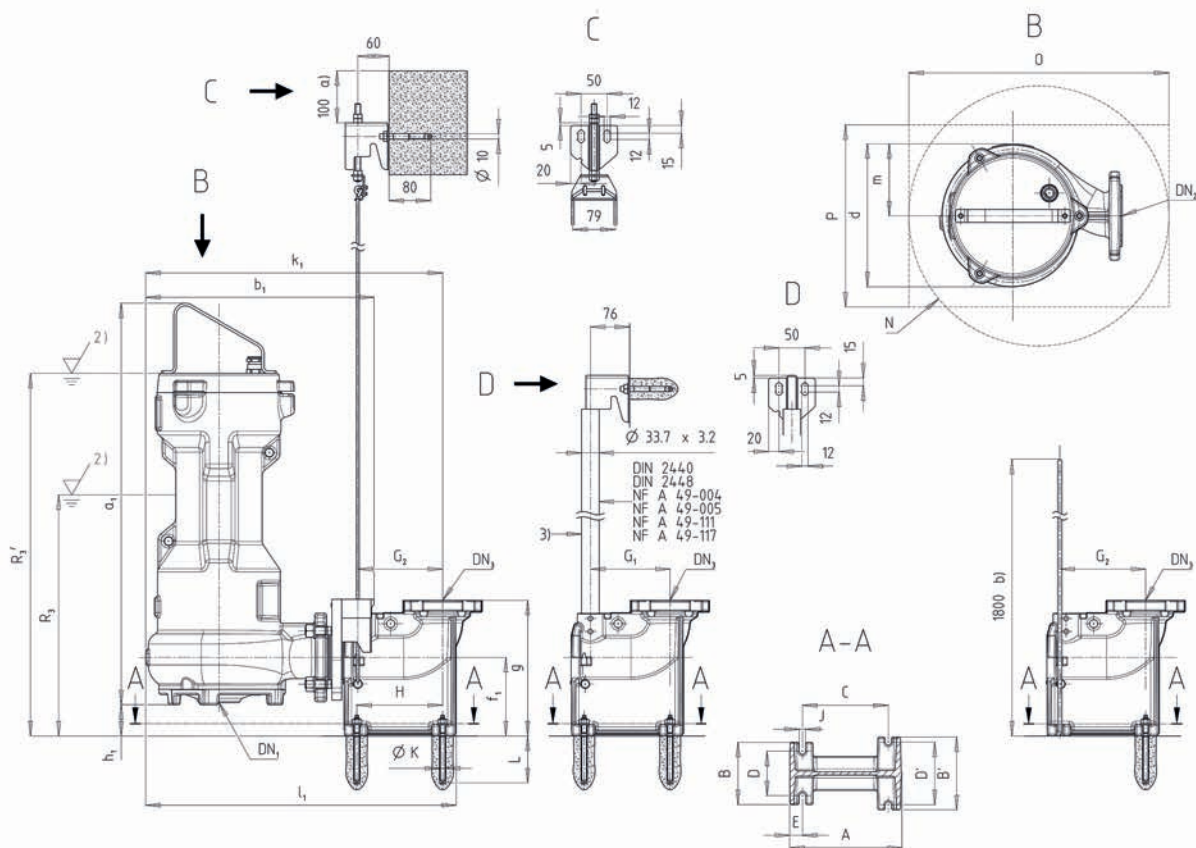

Fig. 5: Amarex 65, stationary installation, guide wire arrangement, single guide rail arrangement, guide hoop arrangement

2)	Minimum submergence for continuous operation
3)	Not included in KSB's scope of supply

Pump set dimensions [mm]

Amarex	Motor rating	Efficiency class	Number of poles	Motor version	Motor construction type	DN ₁	DN ₂	a ₁	b ₁	d	D _f	f ₁	g	g _f	h ₁	H _f	k ₁	k _f	l ₁	m	Z _f	R3	R3'
F065-150	017	F	4	U	S	65	65	691	440	274	170	151	261	118	60	170	569	145	595	138	4	-	636
F065-150	017	F	4	Y	S	65	65	700	440	274	170	151	261	118	60	170	569	145	595	138	4	-	645
F065-150	021	C	4	U	S	65	65	763	440	274	170	151	261	118	60	170	569	145	595	138	4	358	-
F065-150	021	C	4	Y	S	65	65	772	440	274	170	151	261	118	60	170	569	145	595	138	4	367	-
F065-150	035	F	4	U	S	65	65	763	440	274	170	151	261	118	60	170	569	145	595	138	4	-	688
F065-150	035	F	4	Y	S	65	65	772	440	274	170	151	261	118	60	170	569	145	595	138	4	-	697
F065-170	018	C	2	U	S	65	65	691	440	274	170	151	261	118	60	170	569	145	595	138	4	336	-
F065-170	018	C	2	Y	S	65	65	700	440	274	170	151	261	118	60	170	569	145	595	138	4	345	-
F065-170	024	F	2	U	S	65	65	691	440	274	170	151	261	118	60	170	569	145	595	138	4	-	636
F065-170	024	F	2	Y	S	65	65	700	440	274	170	151	261	118	60	170	569	145	595	138	4	-	645
F065-170	029	C	2	U	S	65	65	691	440	274	170	151	261	118	60	170	569	145	595	138	4	421	-
F065-170	029	C	2	Y	S	65	65	700	440	274	170	151	261	118	60	170	569	145	595	138	4	430	-
F065-170	035	C	2	U	S	65	65	763	440	274	170	151	261	118	60	170	569	145	595	138	4	358	-
F065-170	035	C	2	Y	S	65	65	772	440	274	170	151	261	118	60	170	569	145	595	138	4	367	-
F065-170	040	F	2	U	S	65	65	691	440	274	170	151	261	118	60	170	569	145	595	138	4	-	636
F065-170	040	F	2	Y	S	65	65	700	440	274	170	151	261	118	60	170	569	145	595	138	4	-	645
F065-170	045	C	2	U	S	65	65	763	440	274	170	151	261	118	60	170	569	145	595	138	4	378	-

Amarex	Motor rating	Efficiency class	Number of poles	Motor version	Motor construction type	DN ₁	DN ₂	a ₁	b ₁	d	D _f	f ₁	g	g _f	h ₁	H _f	k ₁	k _f	l ₁	m	Z _f	R3	R3'
F065-170	045	C	2	Y	S	65	65	772	440	274	170	151	261	118	60	170	569	145	595	138	4	387	-
F065-170	051	F	2	U	S	65	65	763	440	274	170	151	261	118	60	170	569	145	595	138	4	-	688
F065-170	051	F	2	Y	S	65	65	772	440	274	170	151	261	118	60	170	569	145	595	138	4	-	697
F065-170	073	F	2	U	S	65	65	763	440	274	170	151	261	118	60	170	569	145	595	138	4	-	688
F065-170	073	F	2	Y	S	65	65	772	440	274	170	151	261	118	60	170	569	145	595	138	4	-	697
F065-230	012	C	2	U	S	65	65	691	440	274	170	151	261	118	60	170	569	145	595	138	4	336	-
F065-230	012	C	2	Y	S	65	65	700	440	274	170	151	261	118	60	170	569	145	595	138	4	345	-
F065-230	017	F	4	U	S	65	65	691	440	274	170	151	261	118	60	170	569	145	595	138	4	-	636
F065-230	017	F	4	Y	S	65	65	700	440	274	170	151	261	118	60	170	569	145	595	138	4	-	645
F065-230	021	C	4	U	S	65	65	763	440	274	170	151	261	118	60	170	569	145	595	138	4	358	-
F065-230	021	C	4	Y	S	65	65	772	440	274	170	151	261	118	60	170	569	145	595	138	4	367	-
F065-230	023	F	4	U	S	65	65	691	440	274	170	151	261	118	60	170	569	145	595	138	4	-	636
F065-230	023	F	4	Y	S	65	65	700	440	274	170	151	261	118	60	170	569	145	595	138	4	-	645
F065-230	035	F	4	U	S	65	65	763	440	274	170	151	261	118	60	170	569	145	595	138	4	-	688
F065-230	035	F	4	Y	S	65	65	772	440	274	170	151	261	118	60	170	569	145	595	138	4	-	697
F065-230	042	F	4	U	S	65	65	763	440	274	170	151	261	118	60	170	569	145	595	138	4	-	688
F065-230	042	F	4	Y	S	65	65	772	440	274	170	151	261	118	60	170	569	145	595	138	4	-	697

Foundation dimensions [mm]

Amarex	Motor rating	Efficiency class	Number of poles	Motor version	Motor construction type	DN ₃	A	B	B'	C	D	D'	E	G ₁	G ₂	H	J	ØK	L	N min.	O min.	P min.
F065-150	017	F	4	U	S	65	216	120	140	165	85	120	25	153	165	165	12	10	90	550	550	400
F065-150	017	F	4	Y	S	65	216	120	140	165	85	120	25	153	165	165	12	10	90	550	550	400
F065-150	021	C	4	U	S	65	216	120	140	165	85	120	25	-	165	165	12	10	90	550	550	400
F065-150	021	C	4	Y	S	65	216	120	140	165	85	120	25	-	165	165	12	10	90	550	550	400
F065-150	035	F	4	U	S	65	216	120	140	165	85	120	25	-	165	165	12	10	90	550	550	400
F065-150	035	F	4	Y	S	65	216	120	140	165	85	120	25	-	165	165	12	10	90	550	550	400
F065-170	018	C	2	U	S	65	216	120	140	165	85	120	25	153	165	165	12	10	90	550	550	400
F065-170	018	C	2	Y	S	65	216	120	140	165	85	120	25	153	165	165	12	10	90	550	550	400
F065-170	024	F	2	U	S	65	216	120	140	165	85	120	25	153	165	165	12	10	90	550	550	400
F065-170	024	F	2	Y	S	65	216	120	140	165	85	120	25	153	165	165	12	10	90	550	550	400
F065-170	029	C	2	U	S	65	216	120	140	165	85	120	25	153	165	165	12	10	90	550	550	400
F065-170	029	C	2	Y	S	65	216	120	140	165	85	120	25	153	165	165	12	10	90	550	550	400
F065-170	035	C	2	U	S	65	216	120	140	165	85	120	25	-	165	165	12	10	90	550	550	400
F065-170	035	C	2	Y	S	65	216	120	140	165	85	120	25	-	165	165	12	10	90	550	550	400
F065-170	040	F	2	U	S	65	216	120	140	165	85	120	25	153	165	165	12	10	90	550	550	400
F065-170	040	F	2	Y	S	65	216	120	140	165	85	120	25	153	165	165	12	10	90	550	550	400
F065-170	045	C	2	U	S	65	216	120	140	165	85	120	25	-	165	165	12	10	90	550	550	400
F065-170	045	C	2	Y	S	65	216	120	140	165	85	120	25	-	165	165	12	10	90	550	550	400
F065-170	051	F	2	U	S	65	216	120	140	165	85	120	25	-	165	165	12	10	90	550	550	400
F065-170	051	F	2	Y	S	65	216	120	140	165	85	120	25	-	165	165	12	10	90	550	550	400
F065-170	073	F	2	U	S	65	216	120	140	165	85	120	25	-	165	165	12	10	90	550	550	400
F065-170	073	F	2	Y	S	65	216	120	140	165	85	120	25	-	165	165	12	10	90	550	550	400
F065-230	012	C	2	U	S	65	216	120	140	165	85	120	25	153	165	165	12	10	90	550	550	400

Amarex	Motor rating	Efficiency class	Number of poles	Motor version	Motor construction type	DN ₃	A	B	B'	C	D	D'	E	G ₁	G ₂	H	J	ØK	L	N min.	O min.	P min.
F065-230	012	C	2	Y	S	65	216	120	140	165	85	120	25	153	165	165	12	10	90	550	550	400
F065-230	017	F	4	U	S	65	216	120	140	165	85	120	25	153	165	165	12	10	90	550	550	400
F065-230	017	F	4	Y	S	65	216	120	140	165	85	120	25	153	165	165	12	10	90	550	550	400
F065-230	021	C	4	U	S	65	216	120	140	165	85	120	25	-	165	165	12	10	90	550	550	400
F065-230	021	C	4	Y	S	65	216	120	140	165	85	120	25	-	165	165	12	10	90	550	550	400
F065-230	023	F	4	U	S	65	216	120	140	165	85	120	25	153	165	165	12	10	90	550	550	400
F065-230	023	F	4	Y	S	65	216	120	140	165	85	120	25	153	165	165	12	10	90	550	550	400
F065-230	035	F	4	U	S	65	216	120	140	165	85	120	25	-	165	165	12	10	90	550	550	400
F065-230	035	F	4	Y	S	65	216	120	140	165	85	120	25	-	165	165	12	10	90	550	550	400
F065-230	042	F	4	U	S	65	216	120	140	165	85	120	25	-	165	165	12	10	90	550	550	400
F065-230	042	F	4	Y	S	65	216	120	140	165	85	120	25	-	165	165	12	10	90	550	550	400

Amarex DN 65, stationary installation, twin guide rail arrangement

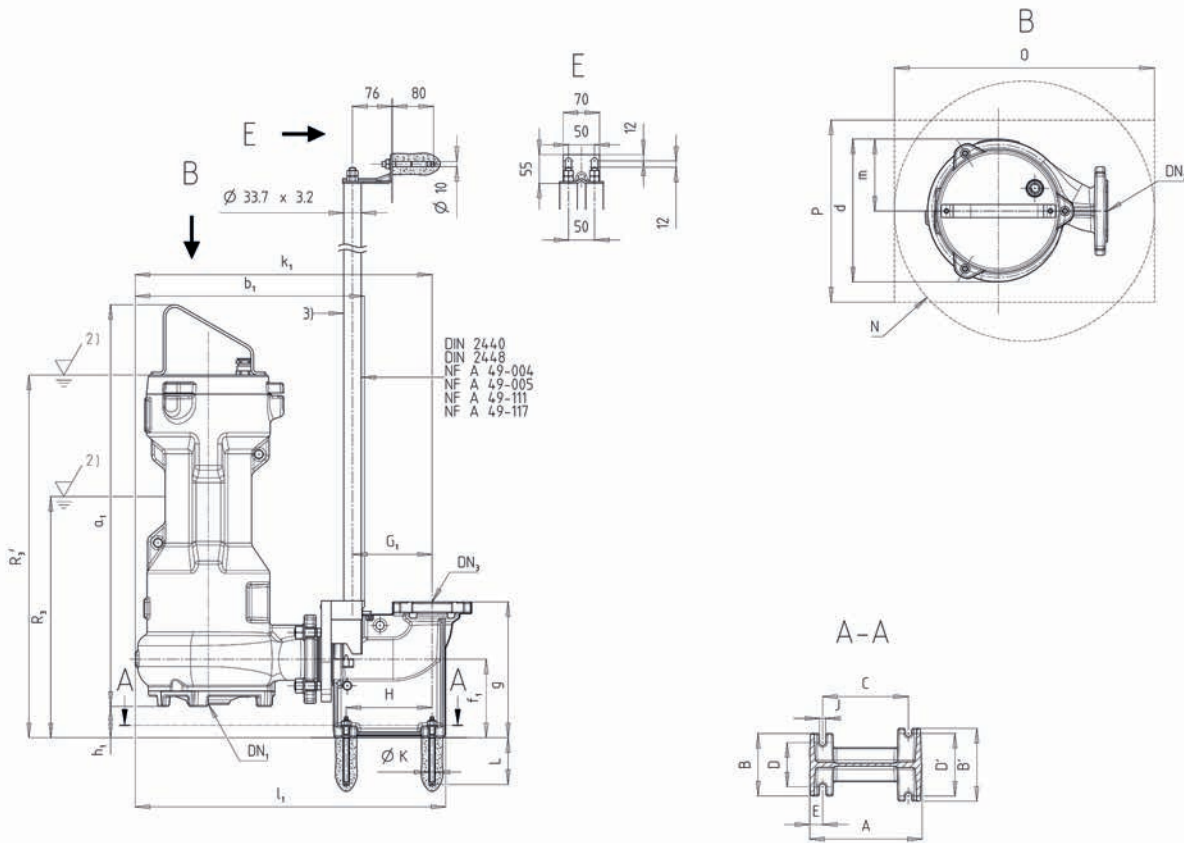

Fig. 6: Amarex 65, stationary installation, twin guide rail arrangement

2)	Minimum submergence for continuous operation
3)	Not included in KSB's scope of supply

Pump set dimensions [mm]

Amarex	Motor rating	Efficiency class	Number of poles	Motor version	Motor construction type	DN ₁	DN ₂	a ₁	b ₁	d	D _f	f ₁	g	g _f	h ₁	H _f	k ₁	k _f	l ₁	m	Z _f	R3	R3'
F065-150	017	F	4	U	S	65	65	691	440	274	170	151	261	118	60	170	569	145	595	138	4	-	636
F065-150	017	F	4	Y	S	65	65	700	440	274	170	151	261	118	60	170	569	145	595	138	4	-	645
F065-150	021	F	4	U	S	65	65	763	440	274	170	151	261	118	60	170	569	145	595	138	4	358	-
F065-150	021	F	4	Y	S	65	65	772	440	274	170	151	261	118	60	170	569	145	595	138	4	367	-
F065-150	035	F	4	U	S	65	65	763	440	274	170	151	261	118	60	170	569	145	595	138	4	-	688
F065-150	035	F	4	Y	S	65	65	772	440	274	170	151	261	118	60	170	569	145	595	138	4	-	697
F065-170	018	F	2	U	S	65	65	691	440	274	170	151	261	118	60	170	569	145	595	138	4	336	-
F065-170	018	F	2	Y	S	65	65	700	440	274	170	151	261	118	60	170	569	145	595	138	4	345	-
F065-170	024	F	2	U	S	65	65	691	440	274	170	151	261	118	60	170	569	145	595	138	4	-	636
F065-170	024	F	2	Y	S	65	65	700	440	274	170	151	261	118	60	170	569	145	595	138	4	-	645
F065-170	029	F	2	U	S	65	65	691	440	274	170	151	261	118	60	170	569	145	595	138	4	421	-
F065-170	029	F	2	Y	S	65	65	700	440	274	170	151	261	118	60	170	569	145	595	138	4	430	-
F065-170	035	F	2	U	S	65	65	763	440	274	170	151	261	118	60	170	569	145	595	138	4	358	-
F065-170	035	F	2	Y	S	65	65	772	440	274	170	151	261	118	60	170	569	145	595	138	4	367	-
F065-170	040	F	2	U	S	65	65	691	440	274	170	151	261	118	60	170	569	145	595	138	4	-	636
F065-170	040	F	2	Y	S	65	65	700	440	274	170	151	261	118	60	170	569	145	595	138	4	-	645
F065-170	045	F	2	U	S	65	65	763	440	274	170	151	261	118	60	170	569	145	595	138	4	378	-
F065-170	045	F	2	Y	S	65	65	772	440	274	170	151	261	118	60	170	569	145	595	138	4	387	-

2573.5/02-EN

Amarex	Motor rating	Efficiency class	Number of poles	Motor version	Motor construction type	DN ₁	DN ₂	a ₁	b ₁	d	D _f	f ₁	g	g _f	h ₁	H _f	k ₁	k _f	l ₁	m	Z _f	R3	R3'
F065-170	051	F	2	U	S	65	65	763	440	274	170	151	261	118	60	170	569	145	595	138	4	-	688
F065-170	051	F	2	Y	S	65	65	772	440	274	170	151	261	118	60	170	569	145	595	138	4	-	697
F065-170	073	F	2	U	S	65	65	763	440	274	170	151	261	118	60	170	569	145	595	138	4	-	688
F065-170	073	F	2	Y	S	65	65	772	440	274	170	151	261	118	60	170	569	145	595	138	4	-	697
F065-230	012	F	2	U	S	65	65	691	440	274	170	151	261	118	60	170	569	145	595	138	4	336	-
F065-230	012	F	2	Y	S	65	65	700	440	274	170	151	261	118	60	170	569	145	595	138	4	345	-
F065-230	017	F	4	U	S	65	65	691	440	274	170	151	261	118	60	170	569	145	595	138	4	-	636
F065-230	017	F	4	Y	S	65	65	700	440	274	170	151	261	118	60	170	569	145	595	138	4	-	645
F065-230	021	F	4	U	S	65	65	763	440	274	170	151	261	118	60	170	569	145	595	138	4	358	-
F065-230	021	F	4	Y	S	65	65	772	440	274	170	151	261	118	60	170	569	145	595	138	4	367	-
F065-230	023	F	4	U	S	65	65	691	440	274	170	151	261	118	60	170	569	145	595	138	4	-	636
F065-230	023	F	4	Y	S	65	65	700	440	274	170	151	261	118	60	170	569	145	595	138	4	-	645
F065-230	035	F	4	U	S	65	65	763	440	274	170	151	261	118	60	170	569	145	595	138	4	-	688
F065-230	035	F	4	Y	S	65	65	772	440	274	170	151	261	118	60	170	569	145	595	138	4	-	697
F065-230	042	F	4	U	S	65	65	763	440	274	170	151	261	118	60	170	569	145	595	138	4	-	688
F065-230	042	F	4	Y	S	65	65	772	440	274	170	151	261	118	60	170	569	145	595	138	4	-	697

Foundation dimensions [mm]

Amarex	Motor rating	Efficiency class	Number of poles	Motor version	Motor construction type	DN ₃	A	B	B'	C	D	D'	E	G ₁	G ₂	H	J	ØK	L	N min.	O min.	P min.
F065-150	017	F	4	U	S	65	216	120	140	165	85	120	25	153	-	165	12	10	90	550	550	400
F065-150	017	F	4	Y	S	65	216	120	140	165	85	120	25	153	-	165	12	10	90	550	550	400
F065-150	021	F	4	U	S	65	216	120	140	165	85	120	25	153	-	165	12	10	90	550	550	400
F065-150	021	F	4	Y	S	65	216	120	140	165	85	120	25	153	-	165	12	10	90	550	550	400
F065-150	035	F	4	U	S	65	216	120	140	165	85	120	25	153	-	165	12	10	90	550	550	400
F065-150	035	F	4	Y	S	65	216	120	140	165	85	120	25	153	-	165	12	10	90	550	550	400
F065-170	018	F	2	U	S	65	216	120	140	165	85	120	25	153	-	165	12	10	90	550	550	400
F065-170	018	F	2	Y	S	65	216	120	140	165	85	120	25	153	-	165	12	10	90	550	550	400
F065-170	024	F	2	U	S	65	216	120	140	165	85	120	25	153	-	165	12	10	90	550	550	400
F065-170	024	F	2	Y	S	65	216	120	140	165	85	120	25	153	-	165	12	10	90	550	550	400
F065-170	029	F	2	U	S	65	216	120	140	165	85	120	25	153	-	165	12	10	90	550	550	400
F065-170	029	F	2	Y	S	65	216	120	140	165	85	120	25	153	-	165	12	10	90	550	550	400
F065-170	035	F	2	U	S	65	216	120	140	165	85	120	25	153	-	165	12	10	90	550	550	400
F065-170	035	F	2	Y	S	65	216	120	140	165	85	120	25	153	-	165	12	10	90	550	550	400
F065-170	040	F	2	U	S	65	216	120	140	165	85	120	25	153	-	165	12	10	90	550	550	400
F065-170	040	F	2	Y	S	65	216	120	140	165	85	120	25	153	-	165	12	10	90	550	550	400
F065-170	045	F	2	U	S	65	216	120	140	165	85	120	25	153	-	165	12	10	90	550	550	400
F065-170	045	F	2	Y	S	65	216	120	140	165	85	120	25	153	-	165	12	10	90	550	550	400
F065-170	051	F	2	U	S	65	216	120	140	165	85	120	25	153	-	165	12	10	90	550	550	400
F065-170	051	F	2	Y	S	65	216	120	140	165	85	120	25	153	-	165	12	10	90	550	550	400
F065-170	073	F	2	U	S	65	216	120	140	165	85	120	25	153	-	165	12	10	90	550	550	400
F065-170	073	F	2	Y	S	65	216	120	140	165	85	120	25	153	-	165	12	10	90	550	550	400
F065-230	012	F	2	U	S	65	216	120	140	165	85	120	25	153	-	165	12	10	90	550	550	400
F065-230	012	F	2	Y	S	65	216	120	140	165	85	120	25	153	-	165	12	10	90	550	550	400

Amarex	Motor rating	Efficiency class	Number of poles	Motor version	Motor construction type	DN ₃	A	B	B'	C	D	D'	E	G ₁	G ₂	H	J	ØK	L	N min.	O min.	P min.
F065-230	017	F	4	U	S	65	216	120	140	165	85	120	25	153	-	165	12	10	90	550	550	400
F065-230	017	F	4	Y	S	65	216	120	140	165	85	120	25	153	-	165	12	10	90	550	550	400
F065-230	021	F	4	U	S	65	216	120	140	165	85	120	25	153	-	165	12	10	90	550	550	400
F065-230	021	F	4	Y	S	65	216	120	140	165	85	120	25	153	-	165	12	10	90	550	550	400
F065-230	023	F	4	U	S	65	216	120	140	165	85	120	25	153	-	165	12	10	90	550	550	400
F065-230	023	F	4	Y	S	65	216	120	140	165	85	120	25	153	-	165	12	10	90	550	550	400
F065-230	035	F	4	U	S	65	216	120	140	165	85	120	25	153	-	165	12	10	90	550	550	400
F065-230	035	F	4	Y	S	65	216	120	140	165	85	120	25	153	-	165	12	10	90	550	550	400
F065-230	042	F	4	U	S	65	216	120	140	165	85	120	25	153	-	165	12	10	90	550	550	400
F065-230	042	F	4	Y	S	65	216	120	140	165	85	120	25	153	-	165	12	10	90	550	550	400

Amarex DN 80, stationary installation, guide wire arrangement, twin guide rail arrangement

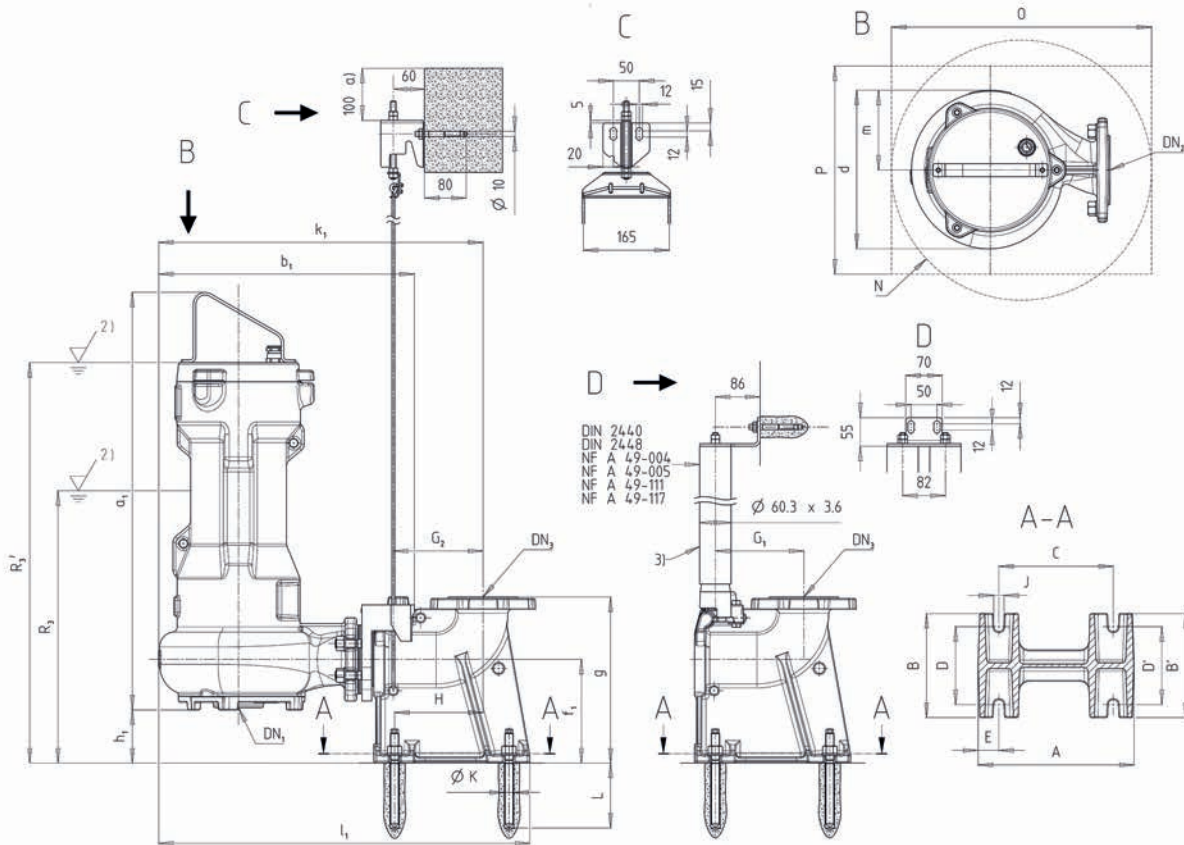

Fig. 7: Amarex 80, stationary installation, guide wire arrangement, twin guide rail arrangement

2)	Minimum submergence for continuous operation
3)	Not included in KSB's scope of supply

Pump set dimensions [mm]

Amarex	Motor rating	Efficiency class	Number of poles	Motor version	Motor construction type	DN ₁	DN ₂	a ₁	b ₁	d	D _f	f ₁	g	g _f	h ₁	H _f	k ₁	k _f	l ₁	m	Z _f	R3	R3'
D080-140	018	C	2	U	S	80	80	670	480	282	160	200	320	132	112	200	611	160	701	154	4	367	-
D080-140	018	C	2	Y	S	80	80	679	480	282	160	200	320	132	112	200	611	160	701	154	4	376	-
D080-140	024	F	2	U	S	80	80	670	480	282	160	200	320	132	112	200	611	160	701	154	4	-	667
D080-140	024	F	2	Y	S	80	80	679	480	282	160	200	320	132	112	200	611	160	701	154	4	-	676
D080-140	029	C	2	U	S	80	80	670	480	282	160	200	320	132	112	200	611	160	701	154	4	452	-
D080-140	029	C	2	Y	S	80	80	679	480	282	160	200	320	132	112	200	611	160	701	154	4	461	-
D080-140	035	C	2	U	S	80	80	698	480	282	160	200	320	132	112	200	611	160	701	154	4	345	-
D080-140	035	C	2	Y	S	80	80	707	480	282	160	200	320	132	112	200	611	160	701	154	4	354	-
D080-140	040	F	2	U	S	80	80	670	480	282	160	200	320	132	112	200	611	160	701	154	4	-	667
D080-140	040	F	2	Y	S	80	80	679	480	282	160	200	320	132	112	200	611	160	701	154	4	-	676
D080-140	051	F	2	U	S	80	80	698	480	282	160	200	320	132	112	200	611	160	701	154	4	-	675
D080-140	051	F	2	Y	S	80	80	707	480	282	160	200	320	132	112	200	611	160	701	154	4	-	684
F080-150	017	F	4	U	S	80	80	701	492	305	160	200	320	132	103	200	623	160	713	154	4	-	689
F080-150	017	F	4	Y	S	80	80	710	492	305	160	200	320	132	103	200	623	160	713	154	4	-	698
F080-150	021	C	4	U	S	80	80	774	491	305	160	200	320	132	103	200	622	160	712	154	4	432	-
F080-150	021	C	4	Y	S	80	80	783	491	305	160	200	320	132	103	200	622	160	712	154	4	441	-
F080-150	035	F	4	U	S	80	80	774	491	305	160	200	320	132	103	200	622	160	712	154	4	-	762
F080-150	035	F	4	Y	S	80	80	783	491	305	160	200	320	132	103	200	622	160	712	154	4	-	771

Amarex	Motor rating	Efficiency class	Number of poles	Motor version	Motor construction type	DN ₁	DN ₂	a ₁	b ₁	d	D _f	f ₁	g	g _f	h ₁	H _f	k ₁	k _f	l ₁	m	Z _f	R3	R3'
D080-170	035	C	2	U	S	80	80	743	497	311	160	200	320	132	112	200	628	160	718	166	4	390	-
D080-170	035	C	2	Y	S	80	80	752	497	311	160	200	320	132	112	200	628	160	718	166	4	399	-
D080-170	045	C	2	U	S	80	80	743	497	311	160	200	320	132	112	200	628	160	718	166	4	410	-
D080-170	045	C	2	Y	S	80	80	752	497	311	160	200	320	132	112	200	628	160	718	166	4	419	-
D080-170	051	F	2	U	S	80	80	743	497	311	160	200	320	132	112	200	628	160	718	166	4	-	720
D080-170	051	F	2	Y	S	80	80	752	497	311	160	200	320	132	112	200	628	160	718	166	4	-	729
D080-170	060	C	2	U	S	80	80	763	497	311	160	200	320	132	112	200	628	160	718	166	4	450	-
D080-170	060	C	2	Y	S	80	80	772	497	311	160	200	320	132	112	200	628	160	718	166	4	459	-
D080-170	073	F	2	U	S	80	80	743	497	311	160	200	320	132	112	200	628	160	718	166	4	-	720
D080-170	073	F	2	Y	S	80	80	752	497	311	160	200	320	132	112	200	628	160	718	166	4	-	729
D080-170	084	F	2	U	S	80	80	763	497	311	160	200	320	132	112	200	628	160	718	166	4	-	740
D080-170	084	F	2	Y	S	80	80	772	497	311	160	200	320	132	112	200	628	160	718	166	4	-	749
D080-180	017	F	2	U	S	90	80	670	480	282	160	200	320	132	112	200	611	160	701	154	4	-	667
D080-180	017	F	2	Y	S	90	80	679	480	282	160	200	320	132	112	200	611	160	701	154	4	-	676
F080-180	017	F	4	U	S	80	80	701	492	305	160	200	320	132	103	200	623	160	713	154	4	-	689
F080-180	017	F	4	Y	S	80	80	710	492	305	160	200	320	132	103	200	623	160	713	154	4	-	698
D080-180	021	C	4	U	S	90	80	698	480	282	160	200	320	132	112	200	611	160	701	154	4	345	-
D080-180	021	C	4	Y	S	90	80	707	480	282	160	200	320	132	112	200	611	160	701	154	4	354	-
F080-180	021	C	4	U	S	80	80	774	491	305	160	200	320	132	103	200	622	160	712	154	4	432	-
F080-180	021	C	4	Y	S	80	80	783	491	305	160	200	320	132	103	200	622	160	712	154	4	441	-
D080-180	035	F	4	U	S	90	80	698	480	282	160	200	320	132	112	200	611	160	701	154	4	-	675
D080-180	035	F	4	Y	S	90	80	707	480	282	160	200	320	132	112	200	611	160	701	154	4	-	684
F080-180	035	F	4	U	S	80	80	774	491	305	160	200	320	132	103	200	622	160	712	154	4	-	762
F080-180	035	F	4	Y	S	80	80	783	491	305	160	200	320	132	103	200	622	160	712	154	4	-	771
F080-220	018	C	2	U	S	80	80	701	492	305	160	200	320	132	103	200	623	160	713	154	4	389	-
F080-220	018	C	2	Y	S	80	80	710	492	305	160	200	320	132	103	200	623	160	713	154	4	398	-
F080-220	024	F	2	U	S	80	80	701	492	305	160	200	320	132	103	200	623	160	713	154	4	-	689
F080-220	024	F	2	Y	S	80	80	710	492	305	160	200	320	132	103	200	623	160	713	154	4	-	698
F080-220	029	C	2	U	S	80	80	701	492	305	160	200	320	132	103	200	623	160	713	154	4	474	-
F080-220	029	C	2	Y	S	80	80	710	492	305	160	200	320	132	103	200	623	160	713	154	4	483	-
F080-220	035	C	2	U	S	80	80	774	491	305	160	200	320	132	103	200	622	160	712	154	4	432	-
F080-220	035	C	2	Y	S	80	80	783	491	305	160	200	320	132	103	200	622	160	712	154	4	441	-
F080-220	040	F	2	U	S	80	80	701	492	305	160	200	320	132	103	200	623	160	713	154	4	-	689
F080-220	040	F	2	Y	S	80	80	710	492	305	160	200	320	132	103	200	623	160	713	154	4	-	698
F080-220	045	C	2	U	S	80	80	774	491	305	160	200	320	132	103	200	622	160	712	154	4	452	-
F080-220	045	C	2	Y	S	80	80	783	491	305	160	200	320	132	103	200	622	160	712	154	4	461	-
F080-220	051	F	2	U	S	80	80	774	491	305	160	200	320	132	103	200	622	160	712	154	4	-	762
F080-220	051	F	2	Y	S	80	80	783	491	305	160	200	320	132	103	200	622	160	712	154	4	-	771
F080-220	060	C	2	U	S	80	80	794	491	305	160	200	320	132	103	200	622	160	712	154	4	492	-
F080-220	060	C	2	Y	S	80	80	803	491	305	160	200	320	132	103	200	622	160	712	154	4	501	-
F080-220	073	F	2	U	S	80	80	774	491	305	160	200	320	132	103	200	622	160	712	154	4	-	762
F080-220	073	F	2	Y	S	80	80	783	491	305	160	200	320	132	103	200	622	160	712	154	4	-	771
F080-220	084	F	2	U	S	80	80	794	491	305	160	200	320	132	103	200	622	160	712	154	4	-	782
F080-220	084	F	2	Y	S	80	80	803	491	305	160	200	320	132	103	200	622	160	712	154	4	-	791
F080-230	012	C	2	U	S	80	80	701	492	305	160	200	320	132	103	200	623	160	713	154	4	389	-
F080-230	012	C	2	Y	S	80	80	710	492	305	160	200	320	132	103	200	623	160	713	154	4	398	-
F080-230	017	F	4	U	S	80	80	701	492	305	160	200	320	132	103	200	623	160	713	154	4	-	689
F080-230	017	F	4	Y	S	80	80	710	492	305	160	200	320	132	103	200	623	160	713	154	4	-	698
D080-230	021	C	4	U	S	90	80	743	497	311	160	200	320	132	112	200	628	160	718	166	4	390	-
D080-230	021	C	4	Y	S	90	80	752	497	311	160	200	320	132	112	200	628	160	718	166	4	399	-
F080-230	021	C	4	U	S	80	80	774	491	305	160	200	320	132	103	200	622	160	712	154	4	432	-
F080-230	021	C	4	Y	S	80	80	783	491	305	160	200	320	132	103	200	622	160	712	154	4	441	-

Amarex	Motor rating	Efficiency class	Number of poles	Motor version	Motor construction type	DN ₁	DN ₂	a ₁	b ₁	d	D _f	f ₁	g	g _f	h ₁	H _f	k ₁	k _f	l ₁	m	Z _f	R3	R3'
F080-230	023	F	4	U	S	80	80	701	492	305	160	200	320	132	103	200	623	160	713	154	4	-	689
F080-230	023	F	4	Y	S	80	80	710	492	305	160	200	320	132	103	200	623	160	713	154	4	-	698
D080-230	035	F	4	U	S	90	80	743	497	311	160	200	320	132	112	200	628	160	718	166	4	-	720
D080-230	035	F	4	Y	S	90	80	752	497	311	160	200	320	132	112	200	628	160	718	166	4	-	729
F080-230	035	F	4	U	S	80	80	774	491	305	160	200	320	132	103	200	622	160	712	154	4	-	762
F080-230	035	F	4	Y	S	80	80	783	491	305	160	200	320	132	103	200	622	160	712	154	4	-	771
D080-230	036	C	4	U	S	90	80	763	497	311	160	200	320	132	112	200	628	160	718	166	4	390	-
D080-230	036	C	4	Y	S	90	80	772	497	311	160	200	320	132	112	200	628	160	718	166	4	399	-
F080-230	036	C	4	U	S	80	80	794	491	305	160	200	320	132	103	200	622	160	712	154	4	432	-
F080-230	036	C	4	Y	S	80	80	803	491	305	160	200	320	132	103	200	622	160	712	154	4	441	-
D080-230	042	F	4	U	S	90	80	743	497	311	160	200	320	132	112	200	628	160	718	166	4	-	720
D080-230	042	F	4	Y	S	90	80	752	497	311	160	200	320	132	112	200	628	160	718	166	4	-	729
F080-230	042	F	4	U	S	80	80	774	491	305	160	200	320	132	103	200	622	160	712	154	4	-	762
F080-230	042	F	4	Y	S	80	80	783	491	305	160	200	320	132	103	200	622	160	712	154	4	-	771
F080-230	045	C	4	U	S	80	80	794	491	305	160	200	320	132	103	200	622	160	712	154	4	512	-
F080-230	045	C	4	Y	S	80	80	803	491	305	160	200	320	132	103	200	622	160	712	154	4	521	-
D080-230	065	F	4	U	S	90	80	763	497	311	160	200	320	132	112	200	628	160	718	166	4	-	740
D080-230	065	F	4	Y	S	90	80	772	497	311	160	200	320	132	112	200	628	160	718	166	4	-	749
F080-230	065	F	4	U	S	80	80	794	491	305	160	200	320	132	103	200	622	160	712	154	4	-	782
F080-230	065	F	4	Y	S	80	80	803	491	305	160	200	320	132	103	200	622	160	712	154	4	-	791
F080-230	077	F	4	U	S	80	80	794	491	305	160	200	320	132	103	200	622	160	712	154	4	-	782
F080-230	077	F	4	Y	S	80	80	803	491	305	160	200	320	132	103	200	622	160	712	154	4	-	791

Foundation dimensions [mm]

Amarex	Motor rating	Efficiency class	Number of poles	Motor version	Motor construction type	DN ₃	A	B	B'	C	D	D'	E	G ₁	G ₂	H	J	ØK	L	N min.	O min.	P min.
D080-140	018	C	2	U	S	80	300	200	200	220	150	150	40	170	173	170	20	18	125	580	580	400
D080-140	018	C	2	Y	S	80	300	200	200	220	150	150	40	170	173	170	20	18	125	580	580	400
D080-140	024	F	2	U	S	80	300	200	200	220	150	150	40	170	173	170	20	18	125	580	580	400
D080-140	024	F	2	Y	S	80	300	200	200	220	150	150	40	170	173	170	20	18	125	580	580	400
D080-140	029	C	2	U	S	80	300	200	200	220	150	150	40	170	173	170	20	18	125	580	580	400
D080-140	029	C	2	Y	S	80	300	200	200	220	150	150	40	170	173	170	20	18	125	580	580	400
D080-140	035	C	2	U	S	80	300	200	200	220	150	150	40	170	173	170	20	18	125	580	580	400
D080-140	035	C	2	Y	S	80	300	200	200	220	150	150	40	170	173	170	20	18	125	580	580	400
D080-140	040	F	2	U	S	80	300	200	200	220	150	150	40	170	173	170	20	18	125	580	580	400
D080-140	040	F	2	Y	S	80	300	200	200	220	150	150	40	170	173	170	20	18	125	580	580	400
D080-140	051	F	2	U	S	80	300	200	200	220	150	150	40	170	173	170	20	18	125	580	580	400
D080-140	051	F	2	Y	S	80	300	200	200	220	150	150	40	170	173	170	20	18	125	580	580	400
F080-150	017	F	4	U	S	80	300	200	200	220	150	150	40	170	173	170	20	18	125	580	580	400
F080-150	017	F	4	Y	S	80	300	200	200	220	150	150	40	170	173	170	20	18	125	580	580	400
F080-150	021	C	4	U	S	80	300	200	200	220	150	150	40	170	173	170	20	18	125	580	580	400
F080-150	021	C	4	Y	S	80	300	200	200	220	150	150	40	170	173	170	20	18	125	580	580	400
F080-150	035	F	4	U	S	80	300	200	200	220	150	150	40	170	173	170	20	18	125	580	580	400
F080-150	035	F	4	Y	S	80	300	200	200	220	150	150	40	170	173	170	20	18	125	580	580	400

Amarex	Motor rating	Efficiency class	Number of poles	Motor version	Motor construction type	DN ₃	A	B	B'	C	D	D'	E	G ₁	G ₂	H	J	ØK	L	N min.	O min.	P min.
F080-230	023	F	4	U	S	80	300	200	200	220	150	150	40	170	173	170	20	18	125	580	580	400
F080-230	023	F	4	Y	S	80	300	200	200	220	150	150	40	170	173	170	20	18	125	580	580	400
D080-230	035	F	4	U	S	80	300	200	200	220	150	150	40	170	173	170	20	18	125	580	580	400
D080-230	035	F	4	Y	S	80	300	200	200	220	150	150	40	170	173	170	20	18	125	580	580	400
F080-230	035	F	4	U	S	80	300	200	200	220	150	150	40	170	173	170	20	18	125	580	580	400
F080-230	035	F	4	Y	S	80	300	200	200	220	150	150	40	170	173	170	20	18	125	580	580	400
D080-230	036	C	4	U	S	80	300	200	200	220	150	150	40	170	173	170	20	18	125	580	580	400
D080-230	036	C	4	Y	S	80	300	200	200	220	150	150	40	170	173	170	20	18	125	580	580	400
F080-230	036	C	4	U	S	80	300	200	200	220	150	150	40	170	173	170	20	18	125	580	580	400
F080-230	036	C	4	Y	S	80	300	200	200	220	150	150	40	170	173	170	20	18	125	580	580	400
D080-230	042	F	4	U	S	80	300	200	200	220	150	150	40	170	173	170	20	18	125	580	580	400
D080-230	042	F	4	Y	S	80	300	200	200	220	150	150	40	170	173	170	20	18	125	580	580	400
F080-230	042	F	4	U	S	80	300	200	200	220	150	150	40	170	173	170	20	18	125	580	580	400
F080-230	042	F	4	Y	S	80	300	200	200	220	150	150	40	170	173	170	20	18	125	580	580	400
F080-230	045	C	4	U	S	80	300	200	200	220	150	150	40	170	173	170	20	18	125	580	580	400
F080-230	045	C	4	Y	S	80	300	200	200	220	150	150	40	170	173	170	20	18	125	580	580	400
D080-230	065	F	4	U	S	80	300	200	200	220	150	150	40	170	173	170	20	18	125	580	580	400
D080-230	065	F	4	Y	S	80	300	200	200	220	150	150	40	170	173	170	20	18	125	580	580	400
F080-230	065	F	4	U	S	80	300	200	200	220	150	150	40	170	173	170	20	18	125	580	580	400
F080-230	065	F	4	Y	S	80	300	200	200	220	150	150	40	170	173	170	20	18	125	580	580	400
F080-230	077	F	4	U	S	80	300	200	200	220	150	150	40	170	173	170	20	18	125	580	580	400
F080-230	077	F	4	Y	S	80	300	200	200	220	150	150	40	170	173	170	20	18	125	580	580	400

Amarex DN 80, stationary installation, single guide rail arrangement

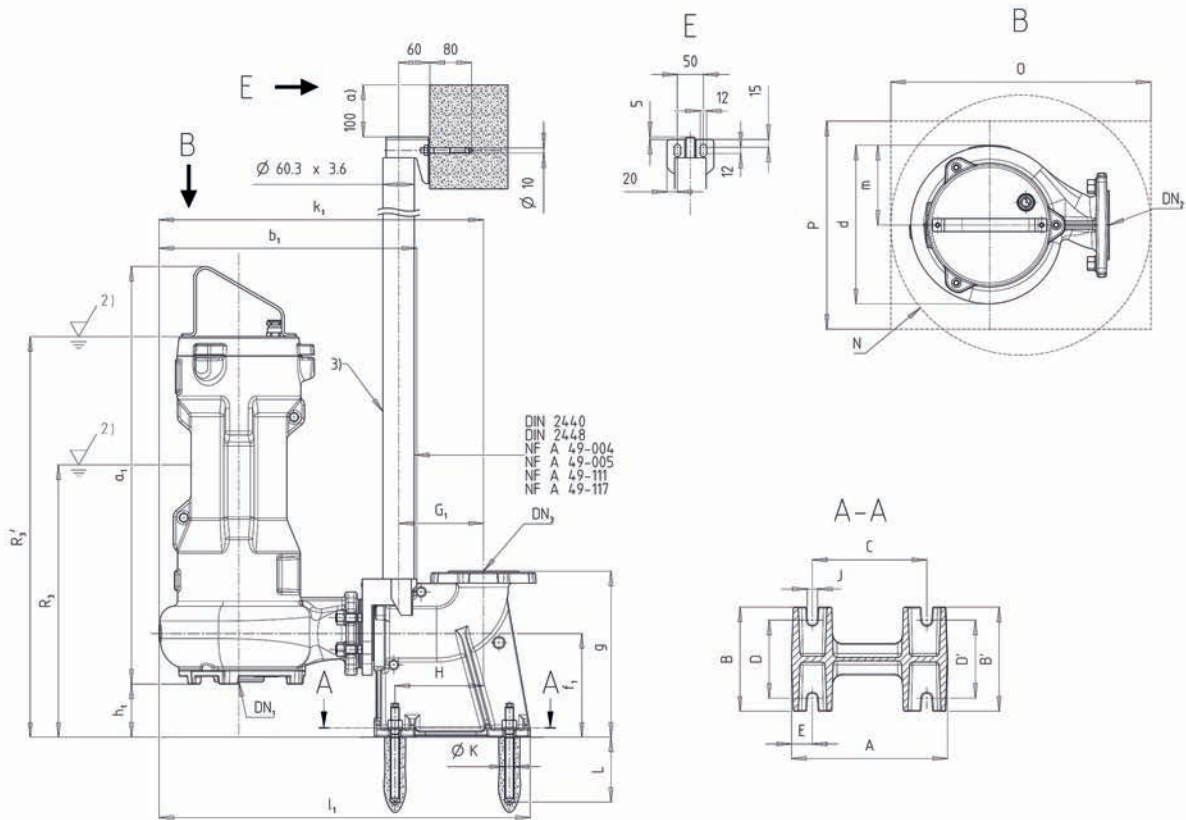

Fig. 8: Amarex 80, stationary installation, single guide rail arrangement

2)	Minimum submergence for continuous operation
3)	Not included in KSB's scope of supply

Pump set dimensions [mm]

Amarex	Motor rating	Efficiency class	Number of poles	Motor version	Motor construction type	DN ₁	DN ₂	a ₁	b ₁	d	D _f	f ₁	g	g _f	h ₁	H _f	k ₁	k _f	l ₁	m	Z _f	R ₃	R ₃ '
D080-140	018	C	2	U	S	80	80	670	480	282	160	200	320	132	112	200	611	160	701	154	4	367	-
D080-140	018	C	2	Y	S	80	80	679	480	282	160	200	320	132	112	200	611	160	701	154	4	376	-
D080-140	024	F	2	U	S	80	80	670	480	282	160	200	320	132	112	200	611	160	701	154	4	-	667
D080-140	024	F	2	Y	S	80	80	679	480	282	160	200	320	132	112	200	611	160	701	154	4	-	676
D080-140	029	C	2	U	S	80	80	670	480	282	160	200	320	132	112	200	611	160	701	154	4	452	-
D080-140	029	C	2	Y	S	80	80	679	480	282	160	200	320	132	112	200	611	160	701	154	4	461	-
D080-140	040	F	2	U	S	80	80	670	480	282	160	200	320	132	112	200	611	160	701	154	4	-	667
D080-140	040	F	2	Y	S	80	80	679	480	282	160	200	320	132	112	200	611	160	701	154	4	-	676
F080-150	017	F	4	U	S	80	80	701	492	305	160	200	320	132	103	200	623	160	713	154	4	-	689
F080-150	017	F	4	Y	S	80	80	710	492	305	160	200	320	132	103	200	623	160	713	154	4	-	698
D080-180	017	F	2	U	S	90	80	670	480	282	160	200	320	132	112	200	611	160	701	154	4	-	667
D080-180	017	F	2	Y	S	90	80	679	480	282	160	200	320	132	112	200	611	160	701	154	4	-	676
F080-180	017	F	4	U	S	80	80	701	492	305	160	200	320	132	103	200	623	160	713	154	4	-	689
F080-180	017	F	4	Y	S	80	80	710	492	305	160	200	320	132	103	200	623	160	713	154	4	-	698
F080-220	018	C	2	U	S	80	80	701	492	305	160	200	320	132	103	200	623	160	713	154	4	389	-
F080-220	018	C	2	Y	S	80	80	710	492	305	160	200	320	132	103	200	623	160	713	154	4	398	-
F080-220	024	F	2	U	S	80	80	701	492	305	160	200	320	132	103	200	623	160	713	154	4	-	689
F080-220	024	F	2	Y	S	80	80	710	492	305	160	200	320	132	103	200	623	160	713	154	4	-	698

2573.5/02-EN

Amarex	Motor rating	Efficiency class	Number of poles	Motor version	Motor construction type	DN ₁	DN ₂	a ₁	b ₁	d	D _f	f ₁	g	g _f	h ₁	H _f	k ₁	k _f	l ₁	m	Z _f	R3	R3'
F080-220	029	C	2	U	S	80	80	701	492	305	160	200	320	132	103	200	623	160	713	154	4	474	-
F080-220	029	C	2	Y	S	80	80	710	492	305	160	200	320	132	103	200	623	160	713	154	4	483	-
F080-220	040	F	2	U	S	80	80	701	492	305	160	200	320	132	103	200	623	160	713	154	4	-	689
F080-220	040	F	2	Y	S	80	80	710	492	305	160	200	320	132	103	200	623	160	713	154	4	-	698
F080-230	012	C	2	U	S	80	80	701	492	305	160	200	320	132	103	200	623	160	713	154	4	389	-
F080-230	012	C	2	Y	S	80	80	710	492	305	160	200	320	132	103	200	623	160	713	154	4	398	-
F080-230	017	F	4	U	S	80	80	701	492	305	160	200	320	132	103	200	623	160	713	154	4	-	689
F080-230	017	F	4	Y	S	80	80	710	492	305	160	200	320	132	103	200	623	160	713	154	4	-	698
F080-230	023	F	4	U	S	80	80	701	492	305	160	200	320	132	103	200	623	160	713	154	4	-	689
F080-230	023	F	4	Y	S	80	80	710	492	305	160	200	320	132	103	200	623	160	713	154	4	-	698

Foundation dimensions [mm]

Amarex	Motor rating	Efficiency class	Number of poles	Motor version	Motor construction type	DN ₃	A	B	B'	C	D	D'	E	G ₁	G ₂	H	J	ØK	L	N min.	O min.	P min.
D080-140	018	C	2	U	S	80	300	200	200	220	150	150	40	163	-	170	20	18	125	580	580	400
D080-140	018	C	2	Y	S	80	300	200	200	220	150	150	40	163	-	170	20	18	125	580	580	400
D080-140	024	F	2	U	S	80	300	200	200	220	150	150	40	163	-	170	20	18	125	580	580	400
D080-140	024	F	2	Y	S	80	300	200	200	220	150	150	40	163	-	170	20	18	125	580	580	400
D080-140	029	C	2	U	S	80	300	200	200	220	150	150	40	163	-	170	20	18	125	580	580	400
D080-140	029	C	2	Y	S	80	300	200	200	220	150	150	40	163	-	170	20	18	125	580	580	400
D080-140	040	F	2	U	S	80	300	200	200	220	150	150	40	163	-	170	20	18	125	580	580	400
D080-140	040	F	2	Y	S	80	300	200	200	220	150	150	40	163	-	170	20	18	125	580	580	400
F080-150	017	F	4	U	S	80	300	200	200	220	150	150	40	163	-	170	20	18	125	580	580	400
F080-150	017	F	4	Y	S	80	300	200	200	220	150	150	40	163	-	170	20	18	125	580	580	400
D080-180	017	F	2	U	S	80	300	200	200	220	150	150	40	163	-	170	20	18	125	580	580	400
D080-180	017	F	2	Y	S	80	300	200	200	220	150	150	40	163	-	170	20	18	125	580	580	400
F080-180	017	F	4	U	S	80	300	200	200	220	150	150	40	163	-	170	20	18	125	580	580	400
F080-180	017	F	4	Y	S	80	300	200	200	220	150	150	40	163	-	170	20	18	125	580	580	400
F080-220	018	C	2	U	S	80	300	200	200	220	150	150	40	163	-	170	20	18	125	580	580	400
F080-220	018	C	2	Y	S	80	300	200	200	220	150	150	40	163	-	170	20	18	125	580	580	400
F080-220	024	F	2	U	S	80	300	200	200	220	150	150	40	163	-	170	20	18	125	580	580	400
F080-220	024	F	2	Y	S	80	300	200	200	220	150	150	40	163	-	170	20	18	125	580	580	400
F080-220	029	C	2	U	S	80	300	200	200	220	150	150	40	163	-	170	20	18	125	580	580	400
F080-220	029	C	2	Y	S	80	300	200	200	220	150	150	40	163	-	170	20	18	125	580	580	400
F080-220	040	F	2	U	S	80	300	200	200	220	150	150	40	163	-	170	20	18	125	580	580	400
F080-220	040	F	2	Y	S	80	300	200	200	220	150	150	40	163	-	170	20	18	125	580	580	400
F080-230	012	C	2	U	S	80	300	200	200	220	150	150	40	163	-	170	20	18	125	580	580	400
F080-230	012	C	2	Y	S	80	300	200	200	220	150	150	40	163	-	170	20	18	125	580	580	400
F080-230	017	F	4	U	S	80	300	200	200	220	150	150	40	163	-	170	20	18	125	580	580	400
F080-230	017	F	4	Y	S	80	300	200	200	220	150	150	40	163	-	170	20	18	125	580	580	400
F080-230	023	F	4	U	S	80	300	200	200	220	150	150	40	163	-	170	20	18	125	580	580	400
F080-230	023	F	4	Y	S	80	300	200	200	220	150	150	40	163	-	170	20	18	125	580	580	400

Amarex DN 100, stationary installation, guide wire arrangement, twin guide rail arrangement

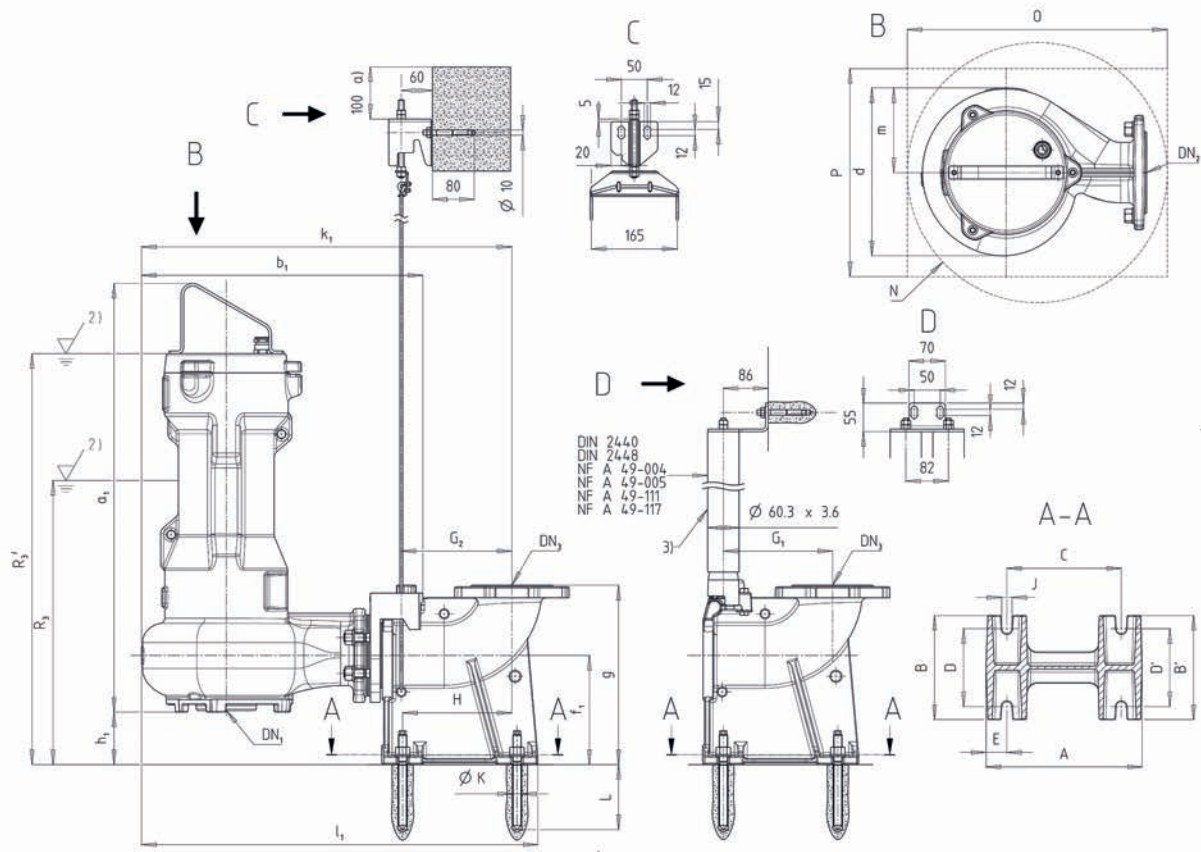

Fig. 9: Amarex 100, stationary installation, guide wire arrangement, twin guide rail arrangement

2)	Minimum submergence for continuous operation
3)	Not included in KSB's scope of supply

Pump set dimensions [mm]

Amarex	Motor rating	Efficiency class	Number of poles	Motor version	Motor construction type	DN ₁	DN ₂	a ₁	b ₁	d	D _f	f ₁	g	g _f	h ₁	H _f	k ₁	k _f	l ₁	m	Z _f	R3	R3'
D100-140	029	C	2	U	S	90	100	689	538	324	180	210	345	156	112	220	708	180	758	185	4	471	-
D100-140	029	C	2	Y	S	90	100	698	538	324	180	210	345	156	112	220	708	180	758	185	4	480	-
D100-140	035	C	2	U	S	90	100	717	538	324	180	210	345	156	112	220	708	180	758	185	4	364	-
D100-140	035	C	2	Y	S	90	100	726	538	324	180	210	345	156	112	220	708	180	758	185	4	373	-
D100-140	040	F	2	U	S	90	100	689	538	324	180	210	345	156	112	220	708	180	758	185	4	-	686
D100-140	040	F	2	Y	S	90	100	698	538	324	180	210	345	156	112	220	708	180	758	185	4	-	695
D100-140	051	F	2	U	S	90	100	717	538	324	180	210	345	156	112	220	708	180	758	185	4	-	694
D100-140	051	F	2	Y	S	90	100	726	538	324	180	210	345	156	112	220	708	180	758	185	4	-	703
D100-170	035	C	2	U	S	90	100	756	547	336	180	210	345	156	112	220	717	180	767	189	4	403	-
D100-170	035	C	2	Y	S	90	100	765	547	336	180	210	345	156	112	220	717	180	767	189	4	412	-
D100-170	045	C	2	U	S	90	100	756	547	336	180	210	345	156	112	220	717	180	767	189	4	423	-
D100-170	045	C	2	Y	S	90	100	765	547	336	180	210	345	156	112	220	717	180	767	189	4	432	-
D100-170	051	F	2	U	S	90	100	756	547	336	180	210	345	156	112	220	717	180	767	189	4	-	733
D100-170	051	F	2	Y	S	90	100	765	547	336	180	210	345	156	112	220	717	180	767	189	4	-	742
D100-170	060	C	2	U	S	90	100	776	547	336	180	210	345	156	112	220	717	180	767	189	4	463	-
D100-170	060	C	2	Y	S	90	100	785	547	336	180	210	345	156	112	220	717	180	767	189	4	472	-
D100-170	073	F	2	U	S	90	100	756	547	336	180	210	345	156	112	220	717	180	767	189	4	-	733
D100-170	073	F	2	Y	S	90	100	765	547	336	180	210	345	156	112	220	717	180	767	189	4	-	742

Amarex	Motor rating	Efficiency class	Number of poles	Motor version	Motor construction type	DN ₁	DN ₂	a ₁	b ₁	d	D _f	f ₁	g	g _f	h ₁	H _f	k ₁	k _f	l ₁	m	Z _f	R3	R3'
D100-170	084	F	2	U	S	90	100	776	547	336	180	210	345	156	112	220	717	180	767	189	4	-	753
D100-170	084	F	2	Y	S	90	100	785	547	336	180	210	345	156	112	220	717	180	767	189	4	-	762
D100-180	017	F	4	U	S	110	100	689	538	324	180	210	345	156	112	220	708	180	758	185	4	-	686
D100-180	017	F	4	Y	S	110	100	698	538	324	180	210	345	156	112	220	708	180	758	185	4	-	695
F100-180	017	F	4	U	S	100	100	724	540	323	180	210	345	156	100	220	710	180	760	163	4	-	709
F100-180	017	F	4	Y	S	100	100	733	540	323	180	210	345	156	100	220	710	180	760	163	4	-	718
D100-180	021	C	4	U	S	110	100	717	538	324	180	210	345	156	112	220	708	180	758	185	4	364	-
D100-180	021	C	4	Y	S	110	100	726	538	324	180	210	345	156	112	220	708	180	758	185	4	373	-
F100-180	021	C	4	U	S	100	100	797	540	323	180	210	345	156	100	220	710	180	760	163	4	432	-
F100-180	021	C	4	Y	S	100	100	806	540	323	180	210	345	156	100	220	710	180	760	163	4	441	-
D100-180	035	F	4	U	S	110	100	717	538	324	180	210	345	156	112	220	708	180	758	185	4	-	694
D100-180	035	F	4	Y	S	110	100	726	538	324	180	210	345	156	112	220	708	180	758	185	4	-	703
F100-180	035	F	4	U	S	100	100	797	540	323	180	210	345	156	100	220	710	180	760	163	4	-	762
F100-180	035	F	4	Y	S	100	100	806	540	323	180	210	345	156	100	220	710	180	760	163	4	-	771
F100-230	012	C	2	U	S	100	100	724	540	323	180	210	345	156	100	220	710	180	760	163	4	409	-
F100-230	012	C	2	Y	S	100	100	733	540	323	180	210	345	156	100	220	710	180	760	163	4	418	-
F100-230	017	F	4	U	S	100	100	724	540	323	180	210	345	156	100	220	710	180	760	163	4	-	709
F100-230	017	F	4	Y	S	100	100	733	540	323	180	210	345	156	100	220	710	180	760	163	4	-	718
D100-230	021	C	4	U	S	110	100	756	547	336	180	210	345	156	112	220	717	180	767	189	4	403	-
D100-230	021	C	4	Y	S	110	100	765	547	336	180	210	345	156	112	220	717	180	767	189	4	412	-
F100-230	021	C	4	U	S	100	100	797	540	323	180	210	345	156	100	220	710	180	760	163	4	432	-
F100-230	021	C	4	Y	S	100	100	806	540	323	180	210	345	156	100	220	710	180	760	163	4	441	-
F100-230	023	F	4	U	S	100	100	724	540	323	180	210	345	156	100	220	710	180	760	163	4	-	709
F100-230	023	F	4	Y	S	100	100	733	540	323	180	210	345	156	100	220	710	180	760	163	4	-	718
D100-230	035	F	4	U	S	110	100	756	547	336	180	210	345	156	112	220	717	180	767	189	4	-	733
D100-230	035	F	4	Y	S	110	100	765	547	336	180	210	345	156	112	220	717	180	767	189	4	-	742
F100-230	035	F	4	U	S	100	100	797	540	323	180	210	345	156	100	220	710	180	760	163	4	-	762
F100-230	035	F	4	Y	S	100	100	806	540	323	180	210	345	156	100	220	710	180	760	163	4	-	771
D100-230	036	C	4	U	S	110	100	776	547	336	180	210	345	156	112	220	717	180	767	189	4	403	-
D100-230	036	C	4	Y	S	110	100	785	547	336	180	210	345	156	112	220	717	180	767	189	4	412	-
F100-230	036	C	4	U	S	100	100	817	540	323	180	210	345	156	100	220	710	180	760	163	4	432	-
F100-230	036	C	4	Y	S	100	100	826	540	323	180	210	345	156	100	220	710	180	760	163	4	441	-
D100-230	042	F	4	U	S	110	100	756	547	336	180	210	345	156	112	220	717	180	767	189	4	-	733
D100-230	042	F	4	Y	S	110	100	765	547	336	180	210	345	156	112	220	717	180	767	189	4	-	742
F100-230	042	F	4	U	S	100	100	797	540	323	180	210	345	156	100	220	710	180	760	163	4	-	762
F100-230	042	F	4	Y	S	100	100	806	540	323	180	210	345	156	100	220	710	180	760	163	4	-	771
F100-230	045	C	4	U	S	100	100	817	540	323	180	210	345	156	100	220	710	180	760	163	4	512	-
F100-230	045	C	4	Y	S	100	100	826	540	323	180	210	345	156	100	220	710	180	760	163	4	521	-
D100-230	065	F	4	U	S	110	100	776	547	336	180	210	345	156	112	220	717	180	767	189	4	-	753
D100-230	065	F	4	Y	S	110	100	785	547	336	180	210	345	156	112	220	717	180	767	189	4	-	762
F100-230	065	F	4	U	S	100	100	817	540	323	180	210	345	156	100	220	710	180	760	163	4	-	782
F100-230	065	F	4	Y	S	100	100	826	540	323	180	210	345	156	100	220	710	180	760	163	4	-	791
F100-230	077	F	4	U	S	100	100	817	540	323	180	210	345	156	100	220	710	180	760	163	4	-	782
F100-230	077	F	4	Y	S	100	100	826	540	323	180	210	345	156	100	220	710	180	760	163	4	-	791

Amarex	Motor rating	Efficiency class	Number of poles	Motor version	Motor construction type	DN ₃	A	B	B'	C	D	D'	E	G ₁	G ₂	H	J	ØK	L	N min.	O min.	P min.
D100-230	042	F	4	Y	S	100	300	200	200	220	150	150	40	210	213	210	20	18	125	650	650	420
F100-230	042	F	4	U	S	100	300	200	200	220	150	150	40	210	213	210	20	18	125	650	650	420
F100-230	042	F	4	Y	S	100	300	200	200	220	150	150	40	210	213	210	20	18	125	650	650	420
F100-230	045	C	4	U	S	100	300	200	200	220	150	150	40	210	213	210	20	18	125	650	650	420
F100-230	045	C	4	Y	S	100	300	200	200	220	150	150	40	210	213	210	20	18	125	650	650	420
D100-230	065	F	4	U	S	100	300	200	200	220	150	150	40	210	213	210	20	18	125	650	650	420
D100-230	065	F	4	Y	S	100	300	200	200	220	150	150	40	210	213	210	20	18	125	650	650	420
F100-230	065	F	4	U	S	100	300	200	200	220	150	150	40	210	213	210	20	18	125	650	650	420
F100-230	065	F	4	Y	S	100	300	200	200	220	150	150	40	210	213	210	20	18	125	650	650	420
F100-230	077	F	4	U	S	100	300	200	200	220	150	150	40	210	213	210	20	18	125	650	650	420
F100-230	077	F	4	Y	S	100	300	200	200	220	150	150	40	210	213	210	20	18	125	650	650	420

Amarex DN 100, stationary installation, single guide rail arrangement

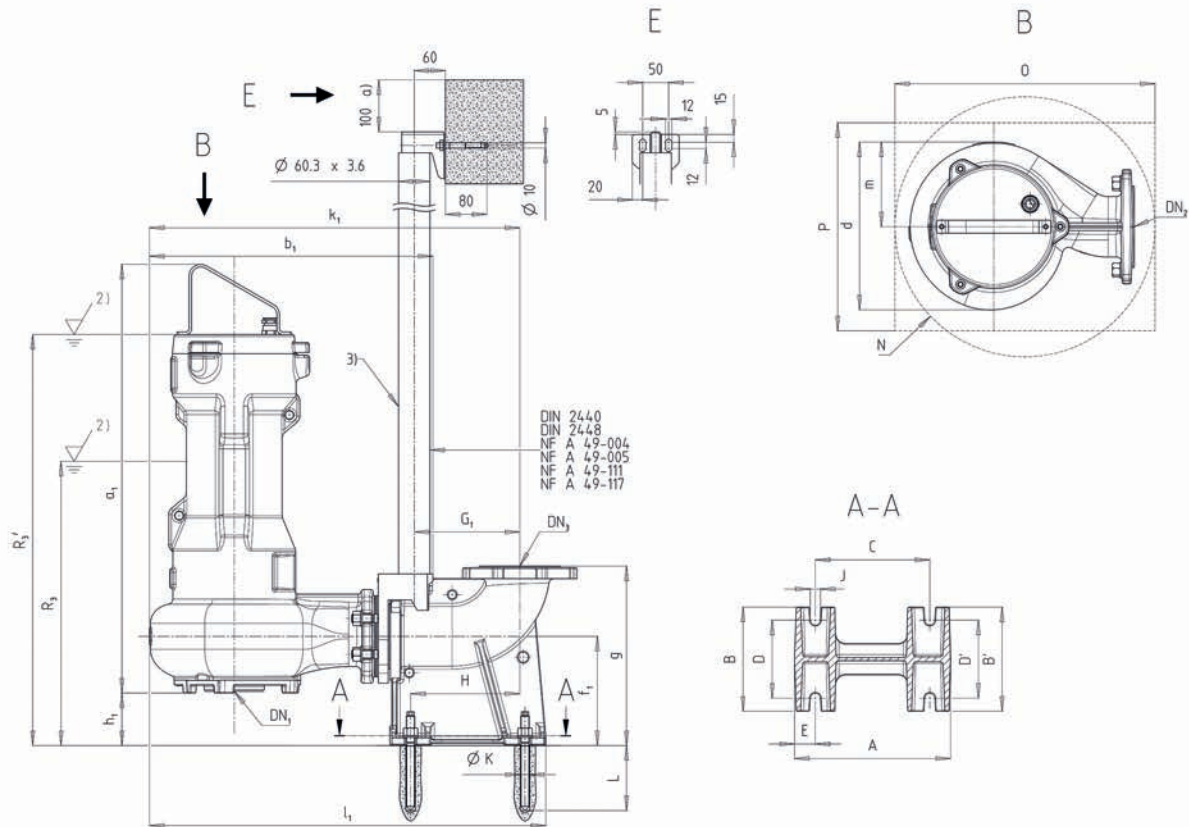

Fig. 10: Amarex 100, stationary installation, single guide rail arrangement

2)	Minimum submergence for continuous operation
3)	Not included in KSB's scope of supply

Pump set dimensions [mm]

Amarex	Motor rating	Efficiency class	Number of poles	Motor version	Motor construction type	DN ₁	DN ₂	a ₁	b ₁	d	D _f	f ₁	g	g _f	h ₁	H _f	k ₁	k _f	l ₁	m	Z _f	R3	R3'
D100-140	029	C	2	U	S	90	100	689	538	324	180	210	345	156	112	220	708	180	758	185	4	471	-
D100-140	029	C	2	Y	S	90	100	698	538	324	180	210	345	156	112	220	708	180	758	185	4	480	-
D100-140	040	F	2	U	S	90	100	689	538	324	180	210	345	156	112	220	708	180	758	185	4	-	686
D100-140	040	F	2	Y	S	90	100	698	538	324	180	210	345	156	112	220	708	180	758	185	4	-	695
D100-180	017	F	4	U	S	110	100	689	538	324	180	210	345	156	112	220	708	180	758	185	4	-	686
D100-180	017	F	4	Y	S	110	100	698	538	324	180	210	345	156	112	220	708	180	758	185	4	-	695
F100-180	017	F	4	U	S	100	100	724	540	323	180	210	345	156	100	220	710	180	760	163	4	-	709
F100-180	017	F	4	Y	S	100	100	733	540	323	180	210	345	156	100	220	710	180	760	163	4	-	718
F100-230	012	C	2	U	S	100	100	724	540	323	180	210	345	156	100	220	710	180	760	163	4	409	-
F100-230	012	C	2	Y	S	100	100	733	540	323	180	210	345	156	100	220	710	180	760	163	4	418	-
F100-230	017	F	4	U	S	100	100	724	540	323	180	210	345	156	100	220	710	180	760	163	4	-	709
F100-230	017	F	4	Y	S	100	100	733	540	323	180	210	345	156	100	220	710	180	760	163	4	-	718
F100-230	023	F	4	U	S	100	100	724	540	323	180	210	345	156	100	220	710	180	760	163	4	-	709
F100-230	023	F	4	Y	S	100	100	733	540	323	180	210	345	156	100	220	710	180	760	163	4	-	718

2573.5/02-EN

Foundation dimensions [mm]

Amarex	Motor rating	Efficiency class	Number of poles	Motor version	Motor construction type	DN ₃	A	B	B'	C	D	D'	E	G ₁	G ₂	H	J	ØK	L	N min.	O min.	P min.
D100-140	029	C	2	U	S	100	300	200	200	220	150	150	40	203	-	210	20	18	125	650	650	420
D100-140	029	C	2	Y	S	100	300	200	200	220	150	150	40	203	-	210	20	18	125	650	650	420
D100-140	040	F	2	U	S	100	300	200	200	220	150	150	40	203	-	210	20	18	125	650	650	420
D100-140	040	F	2	Y	S	100	300	200	200	220	150	150	40	203	-	210	20	18	125	650	650	420
D100-180	017	F	4	U	S	100	300	200	200	220	150	150	40	203	-	210	20	18	125	650	650	420
D100-180	017	F	4	Y	S	100	300	200	200	220	150	150	40	203	-	210	20	18	125	650	650	420
F100-180	017	F	4	U	S	100	300	200	200	220	150	150	40	203	-	210	20	18	125	650	650	420
F100-180	017	F	4	Y	S	100	300	200	200	220	150	150	40	203	-	210	20	18	125	650	650	420
F100-230	012	C	2	U	S	100	300	200	200	220	150	150	40	203	-	210	20	18	125	650	650	420
F100-230	012	C	2	Y	S	100	300	200	200	220	150	150	40	203	-	210	20	18	125	650	650	420
F100-230	017	F	4	U	S	100	300	200	200	220	150	150	40	203	-	210	20	18	125	650	650	420
F100-230	017	F	4	Y	S	100	300	200	200	220	150	150	40	203	-	210	20	18	125	650	650	420
F100-230	023	F	4	U	S	100	300	200	200	220	150	150	40	203	-	210	20	18	125	650	650	420
F100-230	023	F	4	Y	S	100	300	200	200	220	150	150	40	203	-	210	20	18	125	650	650	420

Amarex DN 150, stationary installation, guide wire arrangement, twin guide rail arrangement

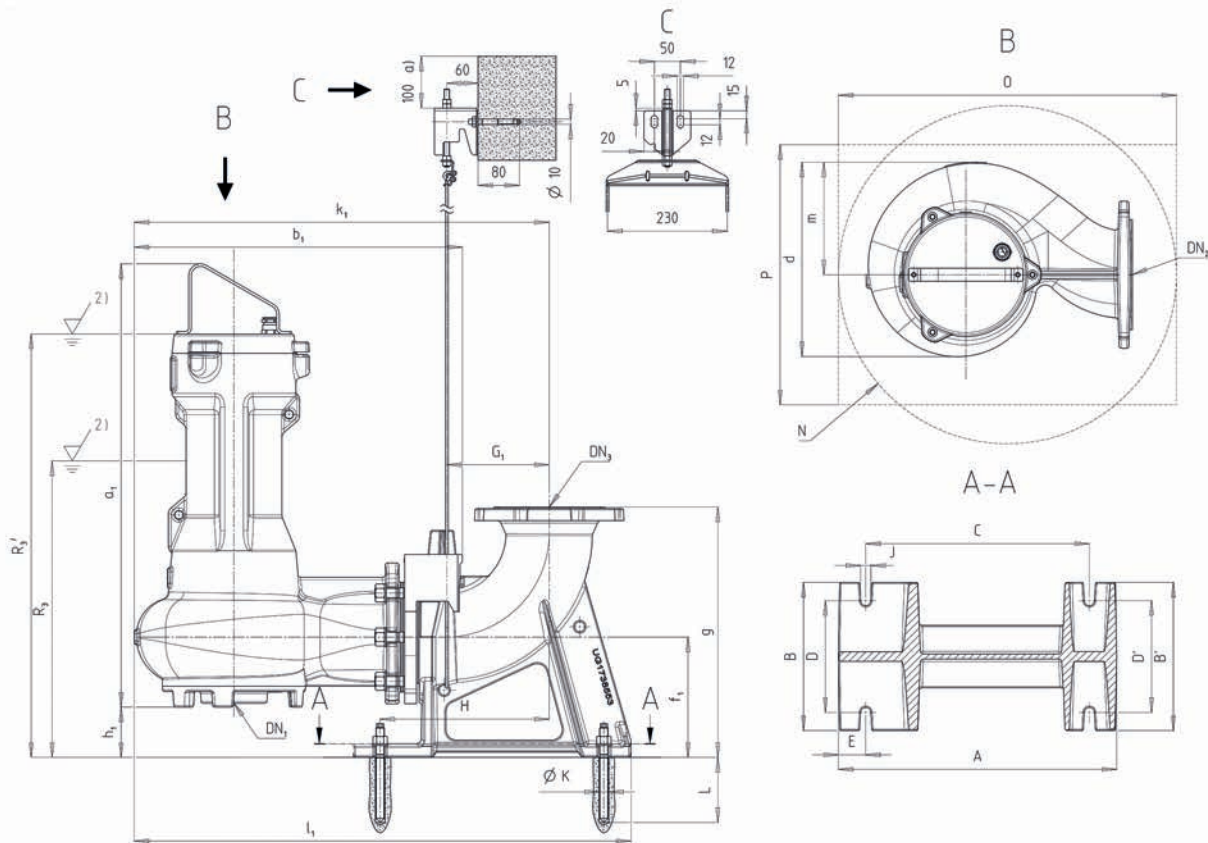

Fig. 11: Amarex 150, stationary installation, guide wire arrangement

2)	Minimum submergence for continuous operation
3)	Not included in KSB's scope of supply

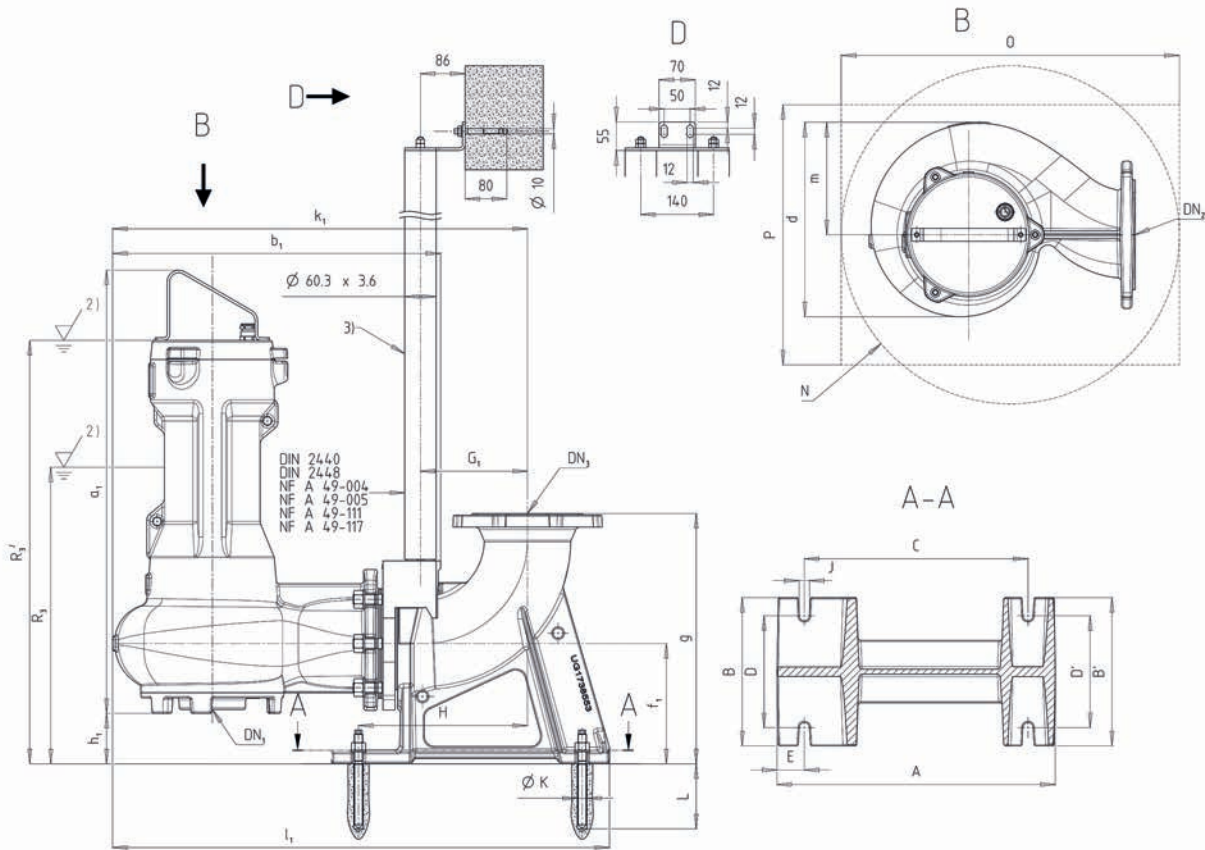

Fig. 12: Amarex 150, stationary installation, twin guide rail arrangement

2)	Minimum submergence for continuous operation
3)	Not included in KSB's scope of supply

Pump set dimensions [mm]

Amarex	Motor rating	Efficiency class	Number of poles	Motor version	Motor construction type	DN ₁	DN ₂	a ₁	b ₁	d	D _f	f ₁	g	g _r	h ₁	H _f	k ₁	k _f	l ₁	m	Z _f	R3	R3'
F150-180	036	C	4	U	S	110	150	844	630	374	271	232	481	211	97	285	796	240	953	216	6	456	-
F150-180	036	C	4	Y	S	110	150	853	630	374	271	232	481	211	97	285	796	240	953	216	6	465	-
F150-180	065	F	4	U	S	110	150	844	630	374	271	232	481	211	97	285	796	240	953	216	6	-	806
F150-180	065	F	4	Y	S	110	150	853	630	374	271	232	481	211	97	285	796	240	953	216	6	-	815
D150-230	036	C	4	U	S	135	150	846	630	374	271	232	481	211	95	285	796	240	953	216	6	456	-
D150-230	036	C	4	Y	S	135	150	855	630	374	271	232	481	211	95	285	796	240	953	216	6	465	-
F150-230	036	C	4	U	S	110	150	844	630	374	271	232	481	211	97	285	796	240	953	216	6	456	-
F150-230	036	C	4	Y	S	110	150	853	630	374	271	232	481	211	97	285	796	240	953	216	6	465	-
D150-230	045	C	4	U	S	135	150	846	630	374	271	232	481	211	95	285	796	240	953	216	6	536	-
D150-230	045	C	4	Y	S	135	150	855	630	374	271	232	481	211	95	285	796	240	953	216	6	545	-
F150-230	045	C	4	U	S	110	150	844	630	374	271	232	481	211	97	285	796	240	953	216	6	536	-
F150-230	045	C	4	Y	S	110	150	853	630	374	271	232	481	211	97	285	796	240	953	216	6	545	-
D150-230	065	F	4	U	S	135	150	846	630	374	271	232	481	211	95	285	796	240	953	216	6	-	806
D150-230	065	F	4	Y	S	135	150	855	630	374	271	232	481	211	95	285	796	240	953	216	6	-	815
F150-230	065	F	4	U	S	110	150	844	630	374	271	232	481	211	97	285	796	240	953	216	6	-	806
F150-230	065	F	4	Y	S	110	150	853	630	374	271	232	481	211	97	285	796	240	953	216	6	-	815
D150-230	077	F	4	U	S	135	150	846	630	374	271	232	481	211	95	285	796	240	953	216	6	-	806

Amarex	Motor rating	Efficiency class	Number of poles	Motor version	Motor construction type	DN ₁	DN ₂	a ₁	b ₁	d	D _f	f ₁	g	g _f	h ₁	H _f	k ₁	k _f	l ₁	m	Z _f	R3	R3'
D150-230	077	F	4	Y	S	135	150	855	630	374	271	232	481	211	95	285	796	240	953	216	6	-	815
F150-230	077	F	4	U	S	110	150	844	630	374	271	232	481	211	97	285	796	240	953	216	6	-	806
F150-230	077	F	4	Y	S	110	150	853	630	374	271	232	481	211	97	285	796	240	953	216	6	-	815

Foundation dimensions [mm]

Amarex	Motor rating	Efficiency class	Number of poles	Motor version	Motor construction type	DN ₃	A	B	B'	C	D	D'	E	G ₁	G ₂	H	J	ØK	L	N min.	O min.	P min.
F150-180	036	C	4	U	S	150	535	285	285	430	215	215	53	206	-	325	20	18	125	730	730	500
F150-180	036	C	4	Y	S	150	535	285	285	430	215	215	53	206	-	325	20	18	125	730	730	500
F150-180	065	F	4	U	S	150	535	285	285	430	215	215	53	206	-	325	20	18	125	730	730	500
F150-180	065	F	4	Y	S	150	535	285	285	430	215	215	53	206	-	325	20	18	125	730	730	500
D150-230	036	C	4	U	S	150	535	285	285	430	215	215	53	206	-	325	20	18	125	730	730	500
D150-230	036	C	4	Y	S	150	535	285	285	430	215	215	53	206	-	325	20	18	125	730	730	500
F150-230	036	C	4	U	S	150	535	285	285	430	215	215	53	206	-	325	20	18	125	730	730	500
F150-230	036	C	4	Y	S	150	535	285	285	430	215	215	53	206	-	325	20	18	125	730	730	500
D150-230	045	C	4	U	S	150	535	285	285	430	215	215	53	206	-	325	20	18	125	730	730	500
D150-230	045	C	4	Y	S	150	535	285	285	430	215	215	53	206	-	325	20	18	125	730	730	500
F150-230	045	C	4	U	S	150	535	285	285	430	215	215	53	206	-	325	20	18	125	730	730	500
F150-230	045	C	4	Y	S	150	535	285	285	430	215	215	53	206	-	325	20	18	125	730	730	500
D150-230	065	F	4	U	S	150	535	285	285	430	215	215	53	206	-	325	20	18	125	730	730	500
D150-230	065	F	4	Y	S	150	535	285	285	430	215	215	53	206	-	325	20	18	125	730	730	500
F150-230	065	F	4	U	S	150	535	285	285	430	215	215	53	206	-	325	20	18	125	730	730	500
F150-230	065	F	4	Y	S	150	535	285	285	430	215	215	53	206	-	325	20	18	125	730	730	500
D150-230	077	F	4	U	S	150	535	285	285	430	215	215	53	206	-	325	20	18	125	730	730	500
D150-230	077	F	4	Y	S	150	535	285	285	430	215	215	53	206	-	325	20	18	125	730	730	500
F150-230	077	F	4	U	S	150	535	285	285	430	215	215	53	206	-	325	20	18	125	730	730	500
F150-230	077	F	4	Y	S	150	535	285	285	430	215	215	53	206	-	325	20	18	125	730	730	500

Connections

Discharge line connections at the duckfoot bend

Flanged connection (DN 50/DN 65)	Threaded connection in the flange (DN 50/DN 65)	Clamped connection (DN 50/DN 65)
	<p>For standard pipes to DIN 2440 / DIN 2441</p> <ul style="list-style-type: none"> ▪ With outside diameter of 60.3 mm, steel for DN 50 ▪ With outside diameter of 63 mm, PVC (ISO 3606) for DN 50 ▪ With threaded flange DN 50 - G 2" ▪ With outside diameter of 76.1 mm, steel for DN 65 ▪ With outside diameter of 75 mm, PVC (ISO 3606) for DN 65 ▪ With threaded flange DN 65 - G 2 1/2" 	<p>For standard pipes to DIN 2440 / DIN 2441 / DIN 2448</p> <ul style="list-style-type: none"> ▪ With outside diameter of 60.3 mm, steel for DN 50 ▪ With outside diameter of 63 mm, PVC (ISO 3606) for DN 50 ▪ With outside diameter of 76.1 mm, steel for DN 65 ▪ With outside diameter of 75 mm, PVC (ISO 3606) for DN 65

Installation types

Installation type S, stationary wet installation

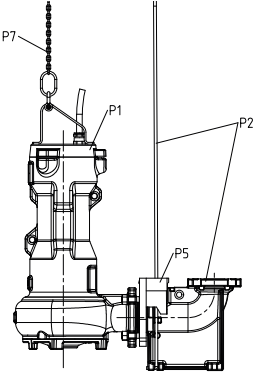
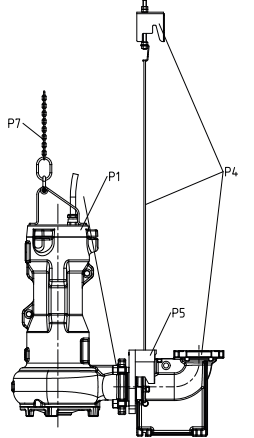
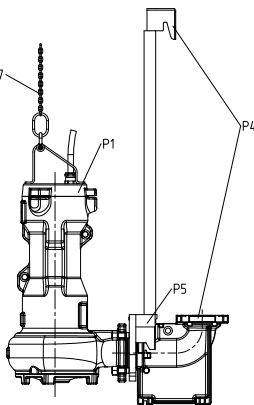
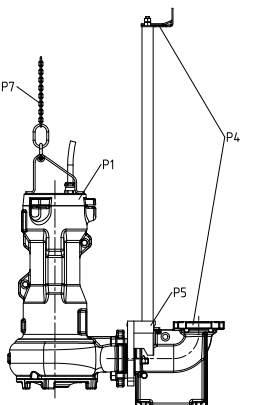
Installation type	Description	Comment
	<p>Guide hoop arrangement</p> <p>P1: pump P2: installation parts for guide hoop arrangement, installation depth = 1.5 m / 1.8 m / 2.1 m P5: claw P7: chain and shackle</p>	<p>Only available for specific sizes, see selection configurator.</p>
	<p>Guide wire arrangement</p> <p>P1: pump P4: installation parts for guide wire arrangement, installation depth = 4.5 m / 9.5 m / 14.5 m P5: claw P7: chain and shackle</p>	
	<p>Single guide rail arrangement</p> <p>P1: pump P4: installation parts for single guide rail arrangement P5: claw P7: chain and shackle</p>	<p>Only available for specific sizes, see selection configurator.</p>
	<p>Twin guide rail arrangement</p> <p>P1: pump P4: installation parts for twin guide rail arrangement P5: claw and adapter P7: chain and shackle</p>	

Installation type P, transportable wet-installed model

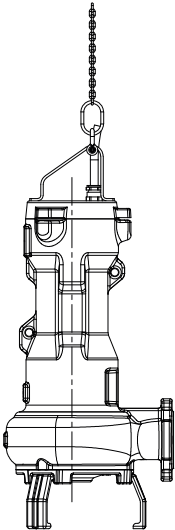
Installation type	Description
	<p>P1: pump P6: pump foot P7: chain and shackle</p>

Installation information

Suggested installation layouts for transportable pump sets

Size 50

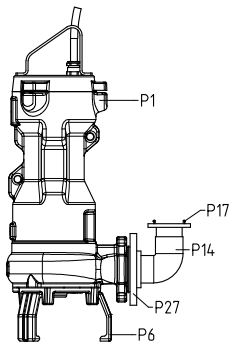

Suggested installation layout 1
Vertical hose connection with elbow (P14) and Storz rigid coupling (P17) (quick connection)

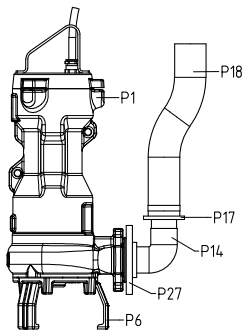

Suggested installation layout 2
Vertical hose connection with plastic hose (P18)

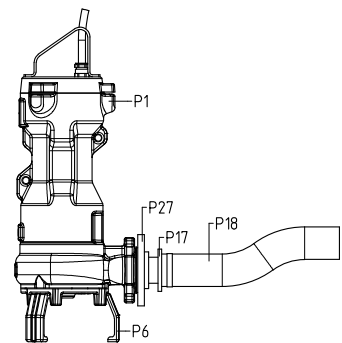

Suggested installation layout 3
Horizontal hose connection (quick connection) with plastic hose (P18)

Sizes 65, 80, 100

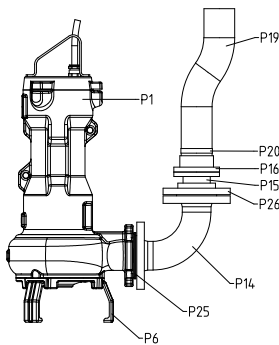

Suggested installation layout 1
Vertical hose connection (quick connection) with plastic hose (P19) and hose clip (P20)

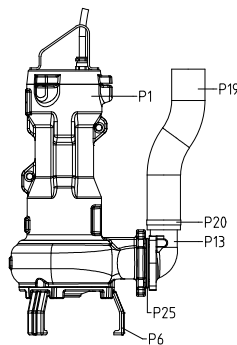

Suggested installation layout 2
Vertical hose connection with plastic hose (P19), hose clip (P20) and connection elbow (P13)

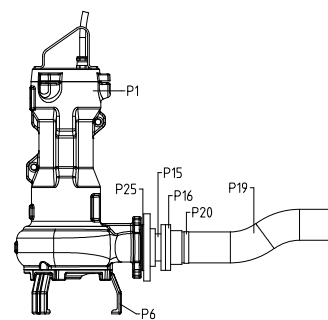

Suggested installation layout 3
Horizontal hose connection (quick connection) with plastic hose (P19), hose clip (P20), Storz hose coupling (P16), Storz rigid coupling (P15)

Suggested installation layouts for stationary pump sets

Sizes 50, 65, 80, 100

Guide hoop arrangement

Amarex S 50-172/F 50-170, S 50-222/F 50-220, F 65-170/65-220

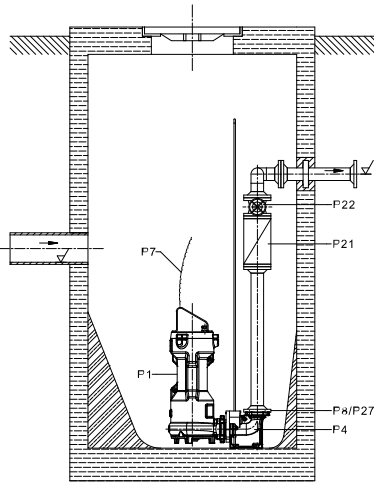

Suggested installation layout 1
Single-pump station
Flanged duckfoot bend

Suspended installation

Amarex S 50-172/F 50-170, S 50-222/F 50-220

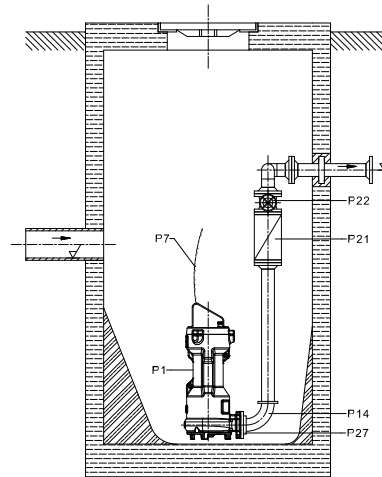

Suggested installation layout 2
Single-pump station for 1.5 m installation depth
Direct connection to discharge line (suspended installation)

Guide wire, single guide rail or twin guide rail arrangement

Amarex 50, 65, 80, 100

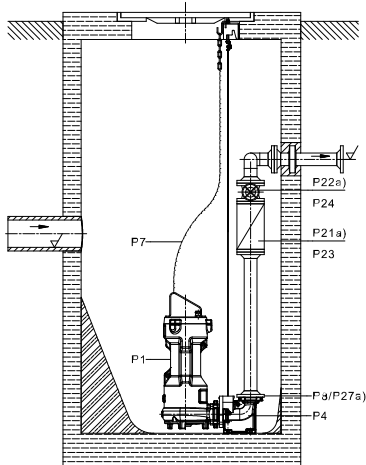

Suggested installation layout 3
Either with guide wire, single guide rail or twin guide rail
arrangement
Single-pump station for 4.5 m installation depth
Flanged duckfoot bend

a)	DN 50 only
----	------------

Suggested electrical installation layouts

Amarex is available in explosion-proof and non-explosionproof design.

CEE motor protection switch (up to 4.0 kW)

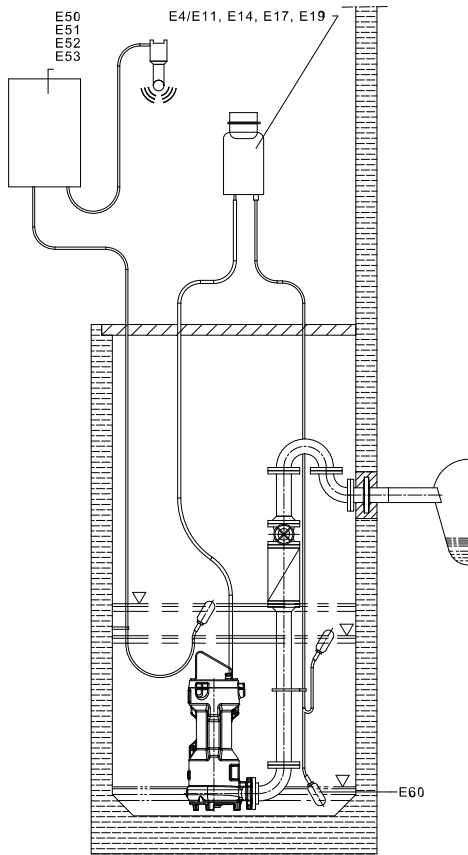

Suggested installation layout 1
without explosion protection

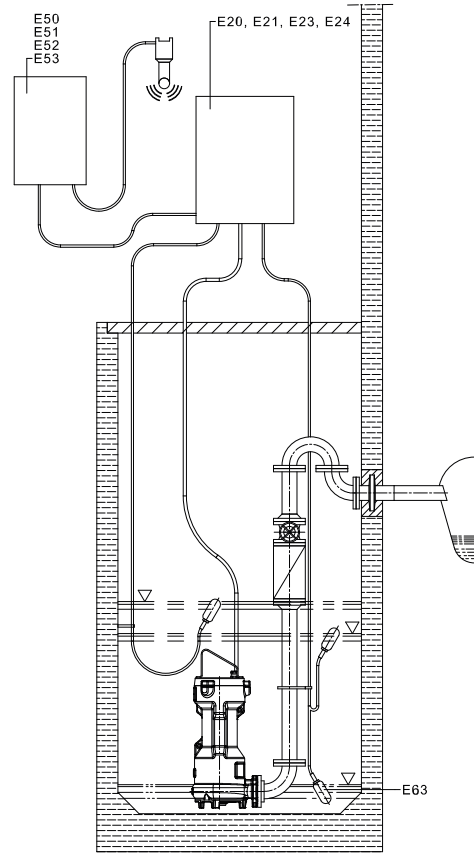

Suggested installation layout 2
with explosion protection

Scope of supply

Stationary wet-installed model (installation type S)

- Pump set, complete with power cable
- Claw with sealing elements and fasteners
- Lifting rope / lifting chain¹⁸⁾
- Mounting bracket with fasteners
- Duckfoot bend with mounting elements
- Guiding equipment¹⁹⁾

Transportable wet-installed model (installation type P)

- Pump set, complete with power cable
- Feet (and foot plate, if applicable)
- Lifting rope / lifting chain²⁰⁾

18) Optional
19) The guide rails are not included in the scope of supply.
20) Optional

Accessories

Installation parts for stationary pump sets

Overview of installation parts for stationary pump sets

	Item	Description	Size	Sealing element	Installation depth [m]	Mat. No.	[kg]
	P2 + P5	Guide hoop arrangement Installation parts for stationary well installation Consisting of: DN 50 flanged duckfoot bend, stainless steel anchor bolts, guide hoop, claw with stainless steel screws/bolts	DN 50 DN 3: DIN ISO ASME Inclined claw	NBR 60	1,5	05045152	12,218
						19521154	1,5
				FKM 60	1,5	05045153	12,218
						19521154	1,5
				NBR 60	1,8	05045152	12,218
						19521155	2,5
				FKM 60	1,8	05045153	12,218
						19521155	2,5
				NBR 60	2,1	05045152	12,218
						19521156	4
				FKM 60	2,1	05045153	12,218
						19521156	4
		Guide hoop arrangement Installation parts for stationary well installation Consisting of: DN 65 flanged duckfoot bend, stainless steel anchor bolts, guide hoop, claw with stainless steel screws/bolts	DN 65 DN 3: DIN ISO ASME	NBR 60	1,5	05045148	16,23
						19521154	1,5
				FKM 60	1,5	05045149	16,23
						19521154	1,5
				NBR 60	1,8	05045148	16,23
						19521155	2,5
				FKM 60	1,8	05045149	16,23
						19521155	2,5
				NBR 60	2,1	05045148	16,23
						19521156	4
				FKM 60	2,1	05045149	16,23
						19521156	4
Guide hoop arrangement Installation parts for stationary well installation Consisting of: DN 65/80 flanged duckfoot bend, stainless steel anchor bolts, guide hoop, claw with stainless steel screws/bolts	DN 65/80 DN 3: DIN ISO	NBR 60	1,5	05045160	18,33		
				19521154	1,5		
		FKM 60	1,5	05045161	18,33		
				19521154	1,5		
		NBR 60	1,8	05045160	18,33		
				19521155	2,5		
		FKM 60	1,8	05045161	18,33		
				19521155	2,5		
		NBR 60	2,1	05045160	18,33		
				19521156	4		
		FKM 60	2,1	05045161	18,33		
				19521156	4		
DN 65/80 DN 3: ASME	NBR 60	1,5	05045156	18,43			
			19521154	1,5			
	FKM 60	1,5	05045157	18,43			
			19521154	1,5			
	NBR 60	1,8	05045156	18,43			
			19521155	2,5			
	FKM 60	1,8	05045157	18,43			
			19521155	2,5			
NBR 60	2,1	05045156	18,43				
		19521156	4				
FKM 60	2,1	05045157	18,43				
		19521156	4				

	Item	Description	Size	Sealing element	Installation depth	Mat. No.	[kg]			
					[m]					
	P4 + P5	Guide wire arrangement Installation parts for stationary well installation Consisting of: flanged duckfoot bend, stainless steel anchor bolts, suspension bracket, mounting bracket, 10 m guide wire, claw with stainless steel screws/bolts	DN 50	NBR 60	4,5	05044127	13,85			
			DN 3: DIN ISO ASME	FKM 60	4,5	05044128	13,85			
			DN 65	NBR 60	4,5	05044125	17,862			
			DN 3: DIN ISO ASME	FKM 60	4,5	05044126	17,862			
			DN 65/80	NBR 60	4,5	05044211	19,962			
			DN 3: DIN ISO	FKM 60	4,5	05044212	19,962			
			DN 65/80	NBR 60	4,5	05044129	20,062			
			DN 3: ASME	FKM 60	4,5	05044210	20,062			
			DN 80	NBR 60	4,5	05018552	29,454			
			DN 3: DIN ISO	FKM 60	4,5	05018553	29,454			
			DN 80	NBR 60	4,5	05028880	27,404			
			DN 3: ASME	FKM 60	4,5	05028881	27,404			
			DN 80/100	NBR 60	4,5	05018556	28,854			
			DN 3: DIN ISO ASME	FKM 60	4,5	05018557	28,854			
			DN 100	NBR 60	4,5	05018554	34,633			
			DN 3: DIN ISO ASME	FKM 60	4,5	05018555	34,633			
			DN 150	NBR 60	4,5	05018558	74,166			
			DN 3: DIN ISO ASME	FKM 60	4,5	05018559	74,166			
				P4 + P5	Single guide rail arrangement Installation parts for stationary well installation Consisting of: flanged duckfoot bend, stainless steel anchor bolts, mounting bracket, claw with stainless steel screws/bolts (guide rail not included in KSB's scope of supply)	DN 50	NBR 60	4,5	05045152	12,218
						DN 3: DIN ISO ASME	FKM 60	4,5	05045153	12,218
							05017151	0,32		
							05017151	0,32		
DN 65	NBR 60	4,5				05045148	16,23			
DN 3: DIN ISO ASME	FKM 60	4,5				05045149	16,23			
							05017151	0,32		
							05017151	0,32		
DN 65/80	NBR 60	4,5				05045160	18,33			
DN 3: DIN ISO	FKM 60	4,5				05045161	18,33			
							05017151	0,32		
DN 65/80	NBR 60	4,5				05045156	18,43			
DN 3: ASME	FKM 60	4,5				05045157	18,43			
							05017151	0,32		
DN 80	NBR 60	4,5				05018726	27,892			
DN 3: DIN ISO	FKM 60	4,5				05018727	27,892			
							05017151	0,32		
DN 80	NBR 60	4,5				05028255	25,892			
DN 3: ASME	FKM 60	4,5				05028256	25,892			
							05017151	0,32		
DN 80/100	NBR 60	4,5	05018742	27,292						
DN 3: DIN ISO ASME	FKM 60	4,5	05018743	27,292						
				05017151	0,32					
DN 100	NBR 60	4,5	05018729	33,071						
DN 3: DIN ISO ASME	FKM 60	4,5	05018740	33,071						
				05017151	0,32					

	Item	Description	Size	Sealing element	Installation depth	Mat. No.	[kg]
					[m]		
	P4 + P5	Twin guide rail arrangement Installation parts for stationary well installation Consisting of: flanged duckfoot bend, stainless steel anchor bolts, mounting bracket, adapter, claw with stainless steel screws/bolts (guide rails not included in KSB's scope of supply)	DN 50	NBR 60	-	05044215	13,33
			DN 3: DIN ISO ASME	FKM 60	-	05044216	13,33
			DN 65	NBR 60	-	05044213	17,242
			DN 3: DIN ISO ASME	FKM 60	-	05044214	17,242
			DN 65/80	NBR 60	-	05044219	19,342
			DN 3: DIN ISO	FKM 60	-	05044220	19,342
			DN 65/80	NBR 60	-	05044217	19,442
			DN 3: ASME	FKM 60	-	05044218	19,442
			DN 80	NBR 60	-	05018645	30,244
			DN 3: DIN ISO	FKM 60	-	05018646	30,244
			DN 80	NBR 60	-	05028447	28,194
			DN 3: ASME	FKM 60	-	05028448	28,194
			DN 80/100	NBR 60	-	05018649	29,644
			DN 3: DIN ISO ASME	FKM 60	-	05018650	29,644
			DN 100	NBR 60	-	05018647	35,423
			DN 3: DIN ISO ASME	FKM 60	-	05018648	35,423
			DN 150	NBR 60	-	05016943	73,25
			DN 3: DIN ISO ASME	FKM 60	-	05016944	73,25
	P5	Guide hoop arrangement, guide wire arrangement, single guide rail arrangement Claw for Amarex EN-GJL-250 with stainless steel screws/bolts	DN 50	NBR 60	-	05046255	4,842
				FKM 60	-	05046256	4,842
		Single guide rail arrangement Claw for Amarex EN-GJL-250 with stainless steel screws/bolts	DN 65	NBR 60	-	05046259	5,854
				FKM 60	-	05046270	5,854
		Single guide rail arrangement Claw for Amarex EN-GJL-250 with stainless steel screws/bolts	DN 80	NBR 60	-	05016790	6,572
				FKM 60	-	05016791	6,572
		Single guide rail arrangement Claw for Amarex EN-GJL-250 with stainless steel screws/bolts	DN 100	NBR 60	-	05016794	7,291
				FKM 60	-	05016795	7,291
		Twin guide rail arrangement Claw for Amarex EN-GJL-250 with stainless steel screws/bolts	DN 50	NBR 60	-	05046257	4,942
				FKM 60	-	05046258	4,942
		Twin guide rail arrangement Claw for Amarex EN-GJL-250 with stainless steel screws/bolts	DN 65	NBR 60	-	05046271	5,854
				FKM 60	-	05046272	5,854
		Guide wire arrangement, twin guide rail arrangement Claw for Amarex EN-GJL-250 with stainless steel screws/bolts	DN 80	NBR 60	-	05016792	6,372
				FKM 60	-	05016793	6,372
		Guide wire arrangement, twin guide rail arrangement Claw for Amarex EN-GJL-250 with stainless steel screws/bolts	DN 100	NBR 60	-	05016796	7
	FKM 60		-	05016797	7,091		
Guide wire arrangement, twin guide rail arrangement Claw for Amarex EN-GJL-250 with stainless steel screws/bolts	DN 150	NBR 60	-	05016798	13,864		
		FKM 60	-	05016799	13,864		

Installation parts transportable pump sets

Overview of installation parts for transportable pump sets

	Item	Description	Size	Mat. No.	[kg]
	P6	3 pump feet	DN 50/65/80/100	05017148	0,072
		Footplate with bolts (only for uneven mounting surfaces and in combination with feet)	DN 50/65/80/100	05016969	1,004

Chain for stationary and transportable pump sets

Overview of chains for stationary and transportable pump sets

	Item	Description	Amarex	Length	Mat. No.	[kg]
				[m]		
	P7	Chain (1.4404) short-linked, tested and duly labelled to Directive 2006/42/EC (Machinery Directive), hook (1.4301), shackle (1.4404), maximum load 200 kg	G08-09	3	05018486	0,793
			G10-11	3	05018487	0,943
			G08-09	5	05018488	2,295
			G10-11	5	05018489	2,445
			G08-09	10	05018510	4,4
			G10-11	10	05018511	4,55
			G08-09	15	05018512	6,605
			G10-11	15	05018513	6,755
	-	Polypropylene lifting rope with shackle 1.4401 and hook 1.4571	G08-09	5	05018515	2,09
			G10-11	5	05018517	2,24

Pump accessories

Overview of accessories for stationary and transportable pump sets

	Item	Description	Connection	Length [m]	Amarex				Mat. No.	[kg]
					50	65	80	100		
	P8	Flange for pipe coupling PN 10, at the flanged elbow, mating dimensions to PN 16	DN 50 / R 2	-	X	-	-	-	19551111	1,2
			DN 65 / R 2 1/2	-	-	X	-	-	39020184	1,2
	P9	PVC adapter for hose connection, with 1 hose clip	R2	-	X	-	-	-	11191498	0,3
	P13	Connection elbow with flange/hose connection made of EN-GJL-250, grey cast iron PN 16, DIN 2501, including joint ring and hose clip; for DN 100 also with fixing bolts, To be used for flange connections item 25 / item 26 (not for DN 100).	DN 65/B 75	-	-	X	-	-	19135655	6
			DN 80/B 75	-	-	-	X	-	19131746	6,6
			DN 100/A 110	-	-	-	-	X	19139718	10
	P14	Angle with internal thread / external thread, galvanised grey cast iron (flange connection see P27 and P30) Connection elbow with flanges PN 16, DIN 2501 (to be used for flange connections item 25 or item 26), grey cast iron	R 2	-	X	-	-	-	00241966	0,3
			DN 65/65	-	-	X	-	-	00265480	11
			DN 65/80	-	-	X	-	-	25198402	8
			DN 80/80	-	-	-	X	-	11150856	10
			DN 100/100	-	-	-	-	X	25145802	14,4
	P15	Storz rigid coupling	DN 65 / B 75	-	-	X	-	-	18040148	3,5
			DN 80/B 75	-	-	-	X	-	18072642	3,5
			DN 100/A 110	-	-	-	-	X	18060162	5
	P16	Storz hose coupling 2 hose clips, item 20, are required for hose mounting (for plastic hoses B 75 and A 110, item 19)	C 52 (DIN 14321)	-	X	-	-	-	00524551	0,3
			B 75 (DIN 14322)	-	-	X	X	-	00520454	0,7
			A 110 (DIN 14323)	-	-	-	-	X	00522313	1,5
	P17	Storz rigid coupling	C 52 / G 2	-	X	-	-	-	00524370	0,2
			B 75 / G 2 1/2	-	-	X	-	-	00524371	0,4
	P18	Plastic hose DN 50, DIN 14811, with integrated C couplings	C 52	-	X	-	-	-	00522262	2,3
			C 52	-	X	-	-	-	00522263	4,2
			C 52	-	X	-	-	-	00522264	5,7
	P19	Plastic hose, without coupling, DIN 14811 63	-	5	X	-	-	-	39018688	1,7
			-	10	X	-	-	-	39018689	3,4
			-	20	X	-	-	-	39018690	6,8
		Plastic hose without coupling, DIN 14 811 B 75	-	5	-	X	X	-	39019064	2
			-	20	-	X	X	-	39019066	8
			-	30	-	X	X	-	39019071	12

	Item	Description	Connection	Length [m]	Amarex				Mat. No.	[kg]
					50	65	80	100		
	P19	Plastic hose without coupling, DIN 14 811 80	-	5	-	-	X	-	39018691	2,2
			-	10	-	-	X	-	39019062	4,3
		Plastic hose without coupling, DIN 14 811 A 110	-	5	-	-	-	X	39019067	4,7
			-	10	-	-	-	X	39019068	9,3
			-	30	-	-	-	X	39019070	27,9
	P20	Hose clip DIN 3017, chrome steel	B 50 ²¹⁾	-	X	-	-	-	39000515	0,025
			B 75	-	-	X	X	-	00109515	0,04
			AL 110 - 120 B ²²⁾	-	-	-	-	X	00520853	0,1
	P21	RK swing check valve	Rp 2	-	X	-	-	-	01009773	0,5
		Plastic, EN 12050-4, with internal thread ISO 7/1, full port and drain plug; cannot be used for pumped drainage								
	P22	Socket gate valve, CuZn, PN 10-12 DIN 3352	Rp 2	-	X	-	-	-	00411503	1,287
			Rp 2 1/2	-	-	X	-	-	39000507	1,7
	P23	Check valve, Grey cast iron, full bore, lifting device, flanges drilled to DIN 2501, PN 16	DN 65	-	-	X	-	-	48829253	13,74
			DN 80	-	-	-	X	-	48829254	16,5
			DN 100	-	-	-	-	X	48829255	20,9
	P24	ECOLINE GTR-16P gate valve, grey cast iron, PN 16, flanges drilled to ISO 7005/DIN 2501	DN 65	-	-	X	-	-	49709579	15
			DN 80	-	-	-	X	-	49709580	22
			DN 100	-	-	-	-	X	49709581	26,5
	P25	Set of installation accessories for a flange connection, discharge nozzle; item 13, 14 or 15 Consisting of: 4 hexagon head bolts with nuts and 1 sealing element	-	-	X	-	-	-	39021944	0,8
			-	-	-	X	-	-	19551115	0,8
			-	-	-	-	X	-	19551100	0,8
			-	-	-	-	-	X	19551113	0,8
	P26	Set of installation accessories for a flange connection Consisting of: 8 hexagon head bolts with nuts and 1 sealing element	-	-	-	-	X	-	19551114	0,8
			-	-	-	-	-	X	19551116	0,8
	P27	Threaded flange for guide hoop arrangement (P2) and guide wire arrangement (P4) Consisting of: flange, 4 hexagon head bolts with nuts and washers and 1 sealing element	DN 50 / Rp 2	-	X	-	-	-	19551353	2
			DN 65 / Rp 2 1/2	-	-	X	-	-	39021943	2,9
	P28	Hand pump, wall mounting, grey cast iron, suction-side connection Rp 1 1/2	-	-	X	X	X	X	00520485	12
	P30	Adapter with reduced external thread M4 EN 1042K	2 x Rp 1 1/4	-	-	-	-	-	01135663	0,4

21) For plastic hose Ø 63 item 19
22) 2 units required

Non-ATEX-compliant control units / switchgear

Overview of control units and switchgear for Amarex, non-ATEX-compliant (Valid for all countries except France.)

	Item	Description	I _N	I _N	Type	Mat. No.	[kg]
			Min.	Max.			
			[A]	[A]			
	E4	Multi-functional plug, type Hyper, with motor protection relay CEE plug	2,6	3,7	Hyper 37.1	19071492	1
			3,7	5,5	Hyper 55.1	19071493	1
			5,5	8,0	Hyper 80.1	19071494	1
			8,0	11,5	Hyper 115.1	19071495	1
LevelControl Basic 2 control unit for single-pump station, IP54							
	E11	For float switch or 4 - 20 mA sensor, optionally with master switch, 400 x 281 x 135 mm	2,5	4,0	BC1 400 DFNO 040	19073763	4,5
			4,0	6,3	BC1 400 DFNO 063	19073764	4,5
			6,3	10,0	BC1 400 DFNO 100	19073765	4,5
	E14	Pneumatic, optional master switch, 400 x 281 x 135 mm	2,5	4,0	BC1 400 DPNO 040	19073768	4,5
			4,0	6,3	BC1 400 DPNO 063	19073769	4,5
			6,3	10,0	BC1 400 DPNO 100	19073770	4,5
	E17	Bubbler control with master switch, 400 x 300 x 155 mm	2,5	4,0	BS1 400 DLNO 040	19073818	12
			4,0	6,3	BS1 400 DLNO 063	19073819	12
			6,3	10,0	BS1 400 DLNO 100	19073820	12
	E19	Bubbler control in BC version Only to be used for connections with a neutral conductor. Optional component O1 (master switch) not possible. 400 x 281 x 135 mm	2,5	4,0	BC1 400 DLNO 040	19075148	4,5
			4,0	6,3	BC1 400 DLNO 063	19075149	4,5
			6,3	10,0	BC1 400 DLNO 100	19075150	4,5
LevelControl Basic 2 control unit for dual-pump station, IP54							
	E31	For float switch or 4 - 20 mA sensor, optionally with master switch, 400 x 281 x 135 mm	2,5	4,0	BC2 400 DFNO 040	19073777	4,7
			4,0	6,3	BC2 400 DFNO 063	19073778	4,7
			6,3	10,0	BC2 400 DFNO 100	19073779	4,7
	E34	Pneumatic, optional master switch, 400 x 281 x 135 mm	2,5	4,0	BC2 400 DPNO 040	19073782	4,7
			4,0	6,3	BC2 400 DPNO 063	19073783	4,7
			6,3	10,0	BC2 400 DPNO 100	19073784	4,7
	E37	Bubbler control with master switch, 400 x 300 x 155 mm	2,5	4,0	BS2 400 DLNO 040	19073860	13
			4,0	6,3	BS2 400 DLNO 063	19073861	13
			6,3	10,0	BS2 400 DLNO 100	19073862	13
	E39	Bubbler control in BC version Only to be used for connections with a neutral conductor. Optional component O1 (master switch) not possible. 400 x 281 x 135 mm	2,5	4,0	BC2 400 DLNO 040	19075151	4,7
			4,0	6,3	BC2 400 DLNO 063	19075152	4,7
			6,3	10,0	BC2 400 DLNO 100	19075153	4,7
LevelControl Basic 2 optional components (processed via KSB EasySelect)²³⁾							
	O1	Master switch for LevelControl Basic 2 BC, fitted	-	-	-	01143084	0,2
	O2	Control cabinet heating for type BS, fitted with 20 W thermostat	-	-	-	19074269	0,3
	O10	Outdoor cabinet type 142 with base, for type BC IP 44, glass fibre reinforced polyester, colour: RAL 7035, locking device: profile half cylinder, can be buried Internal dimensions H x W x D [mm]: 600 x 276 x 165	-	-	-	19071911	15
	O11	Outdoor cabinet type 0/845 for types BS1 (up to 25 A) and BS2 (up to 10 A) IP44, glass fibre reinforced polyester, colour: RAL 7035, DIN 43 629, locking device: profile half cylinder, can be buried, including metal frame for setting in concrete Dimensions H x W x D [mm]: 585 x 845 x 315	-	-	-	19071440	40
	O200	Signalling module for LevelControl Basic 2 BC	-	-	-	19075182	0,2
	O201	Signalling module for type BC, with pressure sensor 3 mWC for redundant pneumatic level measurement or redundant bubbler system	-	-	-	19075183	1,1
	O203	Signalling module for type BS	-	-	-	19075185	1,1

23) Optional components must be processed via KSB EasySelect, otherwise they will be supplied but not fitted.

	Item	Description	I_N	I_N	Type	Mat. No.	[kg]
			Min.	Max.			
			[A]	[A]			
	O204	Signalling module for type BS, with pressure sensor 3 mWC for redundant pneumatic level measurement or redundant bubbler system	-	-	-	19075186	0,8

Overview of control units and switchgear for Amarex, non-ATEX-compliant (Only valid for France.)

	Item	Description	I_N	I_N	Type	Mat. No.	[kg]
			Min.	Max.			
			[A]	[A]			
	E4	Multi-functional plug, type Hyper, with motor protection relay CEE plug	2,6	3,7	Hyper 37.1	19071492	1
			3,7	5,5	Hyper 55.1	19071493	1
			5,5	8,0	Hyper 80.1	19071494	1
			8,0	11,5	Hyper 115.1	19071495	1

LevelControl Basic 2 control unit for single-pump station





	E11	For float switch or 4 - 20 mA sensor, with master switch, 400 x 278 x 120 mm	2,5	4,0	BC1 400 DFNO 040 02	19073878	4,5
			4,0	6,0	BC1 400 DFNO 063 02	19073879	4,5
			6,0	10,0	BC1 400 DFNO 100 02	19073880	4,5
	E14	Pneumatic, with master switch, 400 x 278 x 120 mm	2,5	4,0	BC1 400 DPNO 040 02	²⁴⁾	²⁴⁾
			4,0	6,3	BC1 400 DPNO 063 02	²⁴⁾	²⁴⁾
			6,3	10,0	BC1 400 DPNO 100 02	²⁴⁾	²⁴⁾
	E17	Bubbler control, with master switch, 400 x 300 x 155 mm	2,5	4,0	BS1 400 DLNO 040 02	²⁴⁾	²⁴⁾
			4,0	6,3	BS1 400 DLNO 063 02	²⁴⁾	²⁴⁾
			6,3	10,0	BS1 400 DLNO 100 02	²⁴⁾	²⁴⁾

LevelControl Basic 2 control unit for dual-pump station

	E11	For float switch or 4 - 20 mA sensor, optional master switch, 400 x 278 x 120 mm	2,5	4,0	BC2 400 DFNO 040 02	19073888	4,7
			4,0	6,3	BC2 400 DFNO 063 02	19073889	4,7
			6,0	10,0	BC2 400 DFNO 100 02	19073890	4,7
	E14	Pneumatic, with master switch, 400 x 278 x 120 mm	2,5	4,0	BC2 400 DPNO 040 02	²⁴⁾	²⁴⁾
			4,0	6,3	BC2 400 DPNO 063 02	²⁴⁾	²⁴⁾
			6,3	10,0	BC2 400 DPNO 100 02	²⁴⁾	²⁴⁾
	E17	Bubbler control, with master switch, 400 x 300 x 155 mm	2,5	4,0	BS2 400 DLNO 040 02	²⁴⁾	²⁴⁾
			4,0	6,3	BS2 400 DLNO 063 02	²⁴⁾	²⁴⁾
			6,3	10,0	BS2 400 DLNO 100 02	²⁴⁾	²⁴⁾

Alarm switchgears for pumps, non-ATEX-compliant

AS 0/AS 1/AS 2/AS 4/AS 5

Item	Description	Mat. No.	[kg]
E50	 <p>Alarm switchgear AS 0 with circuit breaker, acoustic signal transmitter with 85 dB(A), green equipment-on lamp Plastic housing, IP20, H x W x D = 140 x 80 x 57 [mm]. Use float switch, F1 leakage sensor (item E64), M1 alarm contactor or signal relay of control unit as contactor.</p>	29128401	0,5
E51	 <p>Alarm switchgear AS 2 with circuit breaker, acoustic signalling device with 85 dB(A), green equipment-on lamp, volt-free contact for hook-up to a control station Plastic housing, IP20, H x W x D = 140 x 80 x 57 [mm]. Use float switch, F1 leakage sensor (item E64) or signal relay of control unit as contactor.</p>	29128422	0,5
E52	 <p>Alarm switchgear AS 4 with circuit breaker, acoustic signal transmitter with 85 dB(A), green equipment-on lamp, volt-free contact for hook-up to a control station, self-charging power supply unit for 5 hours of operation in the event of a power failure Plastic housing, IP20, H x W x D = 140 x 80 x 57 [mm]. Use float switch (E60), F1 leakage sensor (item E64) or signal relay of control unit as contactor.</p>	29128442	0,5
E53	 <p>Alarm switchgear AS 5 Mains-independent, with self-charging power supply unit for 10 hours of operation in the event of a power failure, mains pilot LED, fault indicator light, acknowledgement button, volt-free contact for hook-up to a control station, ready for connection with 1.8 m power cable and plug. ISO housing, IP41, H x W x D = 190 x 165 x 75 [mm]. Use float switch (E60) or signal relay of control unit as contactor.</p>	00530561	1,7
E55	 <p>Alarm switchgear AS 1 In IP30 ISO plug housing, mains-independent, with self-charging power supply unit for 5 hours of operation in the event of a power failure, acoustic signal transmitter 70 dB(A) with circuit breaker and integrated signal transmitter with 3-meter power cable, max. 60 °C, not suitable for steam and condensate.</p> <ol style="list-style-type: none"> 1. High water alert by suspending the sensor in a (pump) sump above the pump start-up point. 2. Water alarm signal at a water level of only 1 mm, by placing the sensor on the floor in areas with a flooding or leakage risk, e.g. the cellar or next to the washing machine in the kitchen or bathroom. 	00533740	0,9

Accessories for non-ATEX-compliant control units

Overview of control unit accessories for Amarex, non-ATEX-compliant

	Item	Description	Length	Mat. No.	[kg]
			[m]		
	E60	Float switch with free cable end Function: circuit closed in upper float position (NO contact) Float switch housing: polypropylene Fluid temperature: 70 °C max. Power cable: H07RN-F3G1	3	11037742	0,5
			5	11037743	0,8
			10	11037744	1,3
			15	11037745	1,8
			20	11037746	2,4
			25	11037747	2,9
			30	11037748	3,4
	E62	Float switch with free cable end Function: circuit open in upper float position (NC contact) Float switch housing: polypropylene Fluid temperature: 70 °C max. Power cable: H07RN-F3G1	5	11037756	0,8
			10	11037757	1,4
			20	11037758	2,6
	E64	F1 leakage sensor Contactor for alarm switchgears AS 0, AS 2, AS 4 or as alarm transmitter for LevelControl Basic 2 Alarm transmission options: High water alert by suspending the sensor in a (pump) sump above the pump start-up point. Warning at a water level of 1 mm in areas with a flooding or leakage risk (e.g. in the cellar or next to the washing machine in the kitchen or bathroom) Dimensions [mm]: 52 x 21 x 20 (H x W x D)	3 m	19072366	0,2
	E65	Open pressure bell set, pneumatic and bubbler control with polyamide tube 8 x 1 mm	10	19071721	1,2
			20	19071837	2
			50	19074200	2,5
	E66	Closed pressure bell set, pneumatic with polyamide tube 8 x 3 mm	10	19071722	3,5
			> 10	On request	
	E70	Horn, 12 V DC, 105 dB, 150 mA, IP54	-	01086547	0,1
	E71	Alarm combination, 12 V DC	-	01139930	0,1
	E72	Yellow alarm strobe light, 12 V DC, 195 mA, IP65	-	01056355	0,3
	O45	Plastic housing, IP65, for easier installation of alarm strobe light, for wall mounting	-	01061067	0,2
	E73	KSB ServiceTool	-	47121210	0,2
	E90	Rechargeable battery retrofit kit for LevelControl Basic 2, type BC Scope of supply: 2 rechargeable batteries (6 V, 1.3 Ah) and charge controller	-	19074194	0,8
	E91	Rechargeable battery retrofit kit for LevelControl Basic 2, type BS Scope of supply: 1 rechargeable battery (12 V, 1.2 Ah) and charge controller	-	19074199	1

LevelControl Basic 2 control units, ATEX-compliant

i Control units for ATEX applications are not explosion-proof, which means that they must not be operated in potentially explosive atmospheres.

i For ATEX-compliant variants, intrinsic safety barriers and an ATEX level switch (float switch) must be fitted. Selection via KSB EasySelect.

Overview of control units and switchgear for Amarex, ATEX-compliant (**i** Valid for all countries except France.)





	Item	Description	I _N	I _N	Type	Mat. No.	[kg]
			Min.	Max.			
			[A]	[A]			
LevelControl Basic 2 control unit for single-pump station							
	E20	Float switch, with master switch, 600 x 400 x 200 mm	2,5	4,0	BS1 400 DFEO 040	19073800	12
			4,0	6,3	BS1 400 DFEO 063	19073801	12
			6,3	10,0	BS1 400 DFEO 100	19073802	12
	E21	Pneumatic, optional master switch, 400 x 281 x 135 mm	2,5	4,0	BC1 400 DPEO 040	19073771	4,5
			4,0	6,3	BC1 400 DPEO 063	19073772	4,5
			6,3	10,0	BC1 400 DPEO 100	19073773	4,5
	E23	Bubbler control with master switch, 400 x 300 x 155 mm	2,5	4,0	BS1 400 DLEO 040	19073821	12
			4,0	6,3	BS1 400 DLEO 063	19073822	12
			6,3	10,0	BS1 400 DLEO 100	19073823	12
	E24	Bubbler control in BC version Only to be used for connections with a neutral conductor. Optional component O1 (master switch) not possible. 400 x 281 x 135 mm	2,5	4,0	BC1 400 DLEO 040	19075154	4,5
			4,0	6,3	BC1 400 DLEO 063	19075155	4,5
			6,3	10,0	BC1 400 DLEO 100	19075156	4,5
LevelControl Basic 2 control unit for dual-pump station							
	E40	Float switch, with master switch, 600 x 400 x 200 mm	2,5	4,0	BS2 400 DFEO 040	19073842	13
			4,0	6,3	BS2 400 DFEO 063	19073843	13
			6,3	10,0	BS2 400 DFEO 100	19073844	13
	E41	Pneumatic, optional master switch, 400 x 281 x 135 mm	2,5	4,0	BC2 400 DPEO 040	19073785	4,7
			4,0	6,3	BC2 400 DPEO 063	19073786	4,7
			6,3	10,0	BC2 400 DPEO 100	19073787	4,7
	E43	Bubbler control with master switch, 400 x 300 x 155 mm	2,5	4,0	BS2 400 DLEO 040	19073863	13
			4,0	6,3	BS2 400 DLEO 063	19073864	13
			6,3	10,0	BS2 400 DLEO 100	19073865	13
	E44	Bubbler control in BC version Only to be used for connections with a neutral conductor. Optional component O1 (master switch) not possible. 400 x 281 x 135 mm	2,5	4,0	BC2 400 DLEO 040	19075157	4,7
			4,0	6,3	BC2 400 DLEO 063	19075158	4,7
			6,3	10,0	BC2 400 DLEO 100	19075159	4,7
LevelControl Basic 2 optional components (processed via KSB EasySelect)²⁵⁾							
	O7	Intrinsic safety barrier for additional float switch in potentially explosive atmospheres for example, high water float switch for pneumatic measurement or bubbler control in potentially explosive atmospheres Only in combination with type BS: Stahl 9002/13-280-093-001	-	-	-	01085568	0,2

Accessories for control units and switchgear for Amarex, ATEX-compliant (**i** Only valid for France!)

	Item	Description	I _N	I _N	Type	Mat. No.	[kg]
			Min.	Max.			
			[A]	[A]			
LevelControl Basic 2 control unit for single-pump station							
	E20	Float switch, with master switch, 600 x 400 x 200 mm	2,5	4,0	BS1 400 DFEO 040 02	²⁶⁾	²⁶⁾
			4,0	6,3	BS1 400 DFEO 063 02	²⁶⁾	²⁶⁾
			6,3	10,0	BS1 400 DFEO 100 02	²⁶⁾	²⁶⁾
	E21	Pneumatic, with master switch, 400 x 278 x 120 mm	2,5	4,0	BC1 400 DPEO 040 02	²⁶⁾	²⁶⁾
			4,0	6,3	BC1 400 DPEO 063 02	²⁶⁾	²⁶⁾
			6,3	10,0	BC1 400 DPEO 100 02	²⁶⁾	²⁶⁾











25) Optional components must be processed via KSB EasySelect, otherwise they will be supplied but not fitted.

26) See KSB EasySelect

	Item	Description	I_N	I_N	Type	Mat. No.	[kg]
			Min.	Max.			
			[A]	[A]			
	E23	Bubbler control, with master switch, 400 x 300 x 155 mm	2,5	4,0	BS1 400 DLEO 040 02	26)	26)
			4,0	6,3	BS1 400 DLEO 063 02	26)	26)
			6,3	10,0	BS1 400 DLEO 100 02	26)	26)
LevelControl Basic 2 control unit for dual-pump station							
	E40	Float switch, with master switch, 600 x 400 x 200 mm	2,5	4,0	BS2 400 DFEO 040 02	26)	26)
			4,0	6,3	BS2 400 DFEO 063 02	26)	26)
			6,3	10,0	BS2 400 DFEO 100 02	26)	26)
	41	Pneumatic, with master switch, 400 x 278 x 120 mm	2,5	4,0	BC2 400 DPEO 040 02	26)	26)
			4,0	6,3	BC2 400 DPEO 063 02	26)	26)
			6,3	10,0	BC2 400 DPEO 100 02	26)	26)
	E43	Bubbler control, with master switch, 400 x 300 x 155 mm	2,5	4,0	BS2 400 DLEO 040 02	26)	26)
			4,0	6,3	BS2 400 DLEO 063 02	26)	26)
			6,3	10,0	BS2 400 DLEO 100 02	26)	26)

Accessories for ATEX-compliant control units

Overview of accessories for Amarex with ATEX

	Item	Description	Length	Mat. No.	[kg]
			[m]		
	E63	Float switch with free cable end (NO contact) With declaration of compliance with explosion protection standards Power cable: (H07RN-F 3G1)	5	01148226	0,7
			10	01148247	1
			20	01148248	2
	E65	Open pressure bell set, pneumatic and bubbler control with polyamide tube 8 x 1 mm	10	19071721	1,2
			20	19071837	2
			50	19074200	2,5
	E66	Closed pressure bell set, pneumatic with polyamide tube 8 x 3 mm	10	19071722	3,5
			> 10	On request	
	E70	Horn, 12 V DC, 105 dB, 150 mA, IP54 - non-explosion-proof	-	01086547	0,1
	E71	Alarm combination, 12 V DC, non-explosion-proof	-	01139930	0,1
	E72	Yellow alarm strobe light, 12 V DC, 195 mA, IP65, non-explosion-proof	-	01056355	0,3
	O45	Plastic housing, IP65, for easier installation of alarm strobe light, for wall mounting	-	01061067	0,2
	E73	KSB ServiceTool	-	47121210	0,2
	E90	Rechargeable battery retrofit kit for LevelControl Basic 2, type BC Scope of supply: 2 rechargeable batteries (6 V, 1.3 Ah) and charge controller	-	19074194	0,8
	E91	Rechargeable battery retrofit kit for LevelControl Basic 2, type BS Scope of supply: 1 rechargeable battery (12 V, 1.2 Ah) and charge controller	-	19074199	1

General assembly drawings with list of components

General assembly drawings for version US

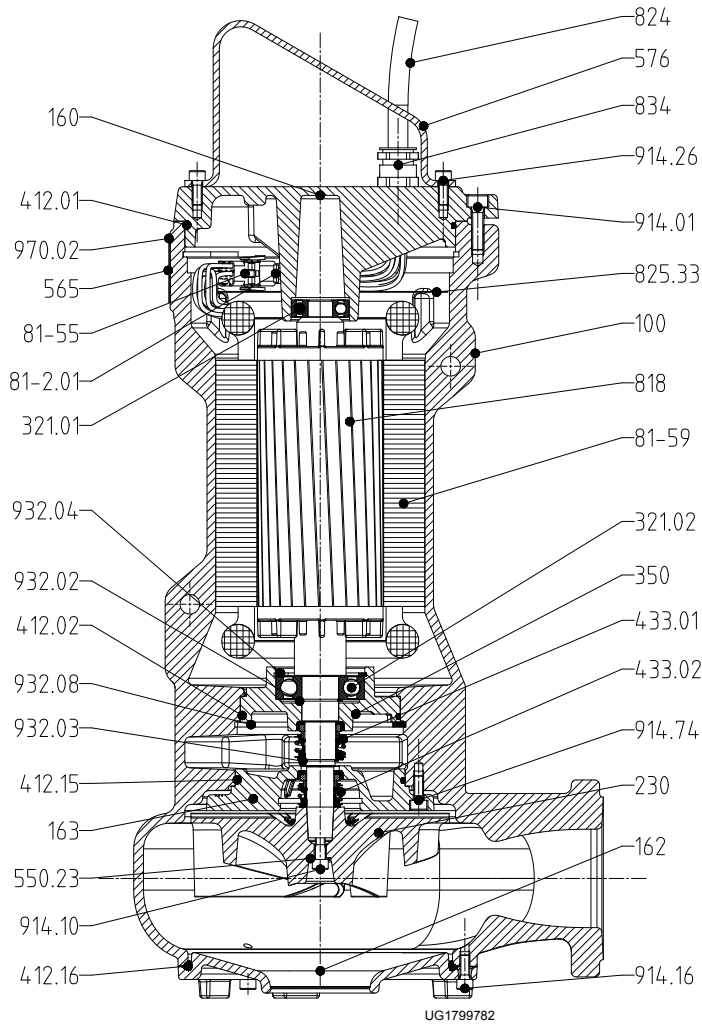

Fig. 13: General assembly drawing for version US, with impeller type F-max

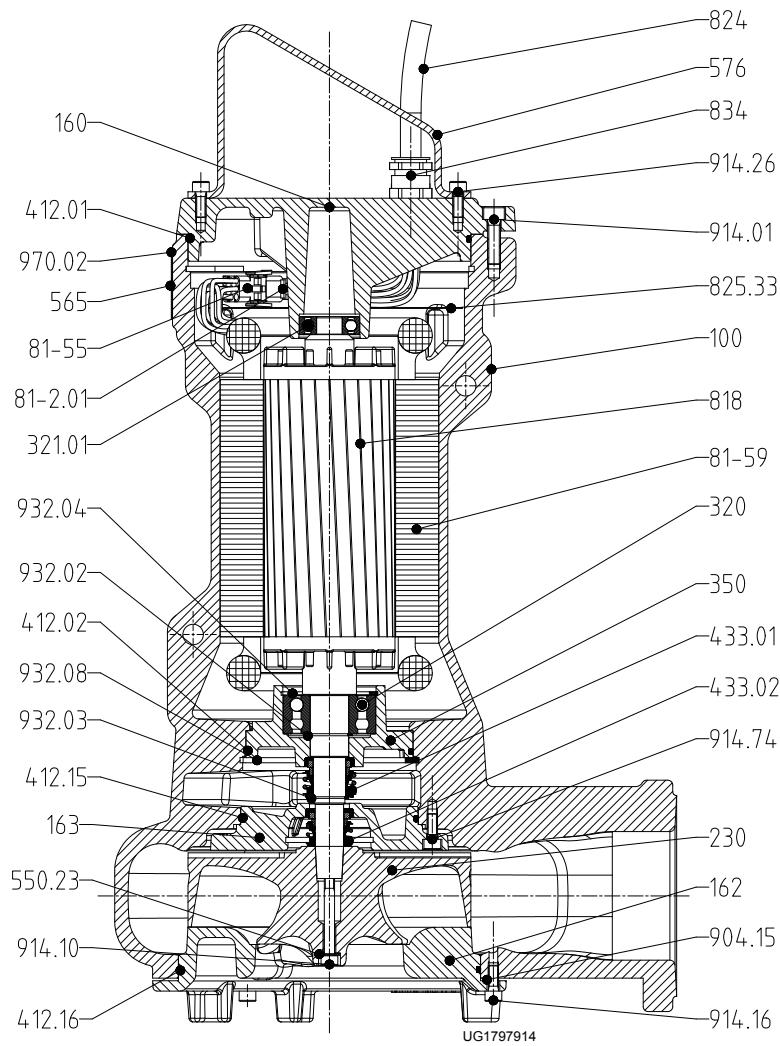

Fig. 14: General assembly drawing for version US, with impeller type D-max

List of components

Part No.	Description	Part No.	Description
100	Casing	576	Handle
160	Cover	81-2.01	Plug
162	Suction cover	81-55	Socket
163	Discharge cover	81-59	Stator
230	Impeller	818	Rotor
320 ²⁷⁾	Rolling element bearing	824	Cable
321.01/.02 ²⁸⁾	Radial ball bearing	825.33	Cable guard
350	Bearing housing	834	Cable gland
412.01/.02/.15/.16	O-ring	904.15 ²⁷⁾	Grub screw
433.01/.02	Mechanical seal	914.01/.10/.16/.26/.74	Hexagon socket head cap screw
550.23	Disc	932.02/.03/.04/.08	Circlip
565	Rivet	970.02	Label/plate

27) Only used for version with impeller type D-max
28) Only used for version with impeller type F-max

General assembly drawing for version YS

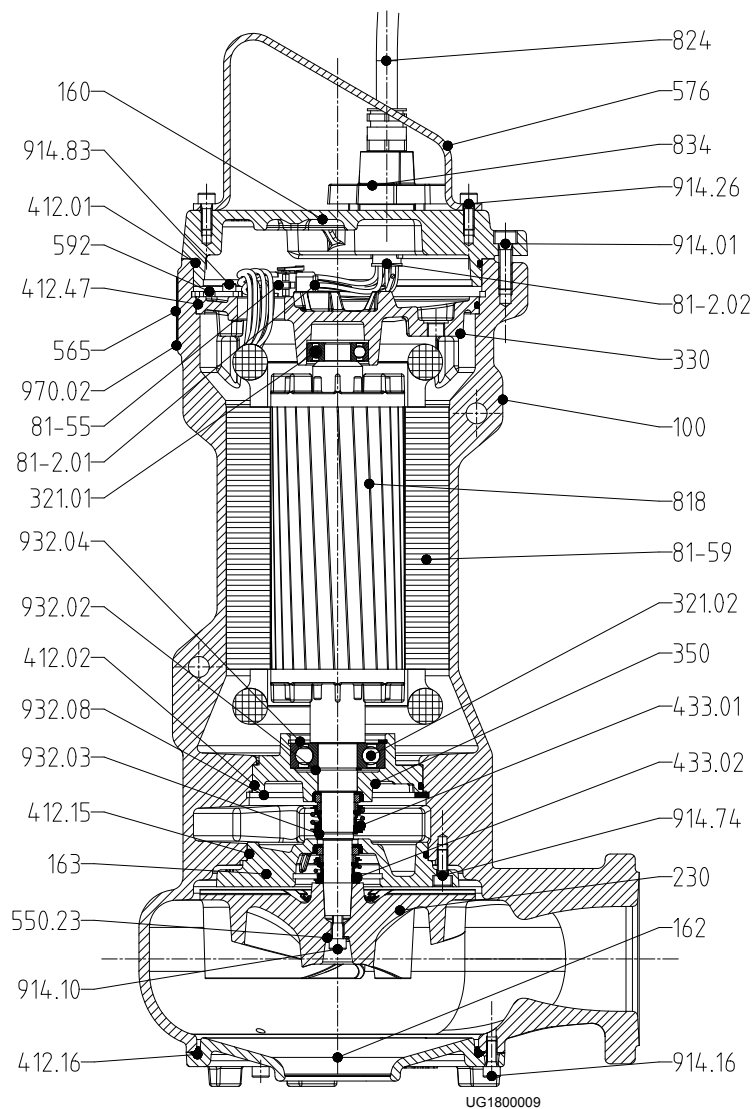

Fig. 15: General assembly drawing for version YS, impeller type F-max

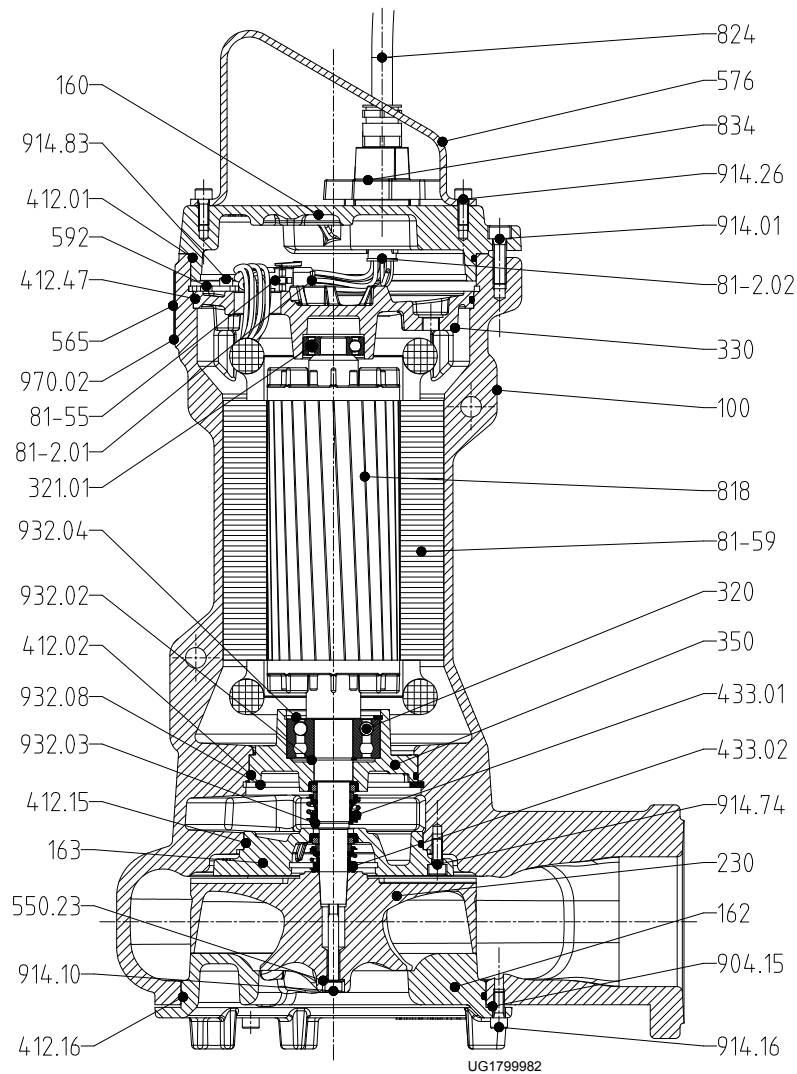

Fig. 16: General assembly drawing for version YS, impeller type D-max

List of components

Part No.	Description	Part No.	Description
100	Casing	576	Handle
160	Cover	592	Plug
162	Suction cover	81-2.01/.02	Plug
163	Discharge cover	81-55	Socket
230	Impeller	81-59	Stator
320 ²⁹⁾	Rolling element bearing	818	Rotor
321.01/.02 ³⁰⁾	Radial ball bearing	824	Cable
330	Bearing bracket	834	Cable gland
350	Bearing housing	904.15 ²⁹⁾	Grub screw
412.01/.02/.15/.16/.47	O-ring	914.01/.10/.16/.26/.74/.83	Hexagon socket head cap screw
433.01/.02	Mechanical seal	932.02/.03/.04/.08	Circlip
550.23	Disc	970.02	Label/plate
565	Rivet		

29) Only used for version with impeller type D-max
30) Only used for version with impeller type F-max

Glossary

Close-coupled design

Motor directly fitted to the pump via a flange or a drive lantern

IE3

Efficiency class to IEC 60034-30: 3 = Premium Efficiency (IE = International Efficiency)

Mat. No.

This identification number is composed of an 8-digit numerical code that uniquely identifies a product entered in SAP.



KSB S.A.S.
128, rue Carnot • 59320 Sequedin (France)
Tél. +33 3 2022-7000 • Fax +33 3 2022-7099
www.ksb.com