

Multistage Horizontal Centrifugal Pump

Comeo

Type Series Booklet



Legal information/Copyright

Type Series Booklet Comeo

All rights reserved. The contents provided herein must neither be distributed, copied, reproduced, edited or processed for any other purpose, nor otherwise transmitted, published or made available to a third party without the manufacturer's express written consent.

Subject to technical modification without prior notice.

© KSB SE & Co. KGaA, Frankenthal 16/04/2020

Contents

Centrifugal Pumps	4
Multistage Horizontal Centrifugal Pumps.....	4
Comeo.....	4
Main applications.....	4
Fluids handled	4
Operating data.....	4
Designation	4
Design details	4
Materials.....	5
Product benefits.....	5
Certifications	5
Selection information	5
Minimum flow rate / maximum flow rate	5
Overview of product features / selection tables	6
Shaft seal	6
Technical data	7
Comeo C, 1~230 V, 50 Hz.....	7
Comeo C, 1~230 V, 60 Hz.....	7
Comeo C, 230/400 V, 50 Hz.....	7
Comeo C, 230/400 V, 60 Hz.....	8
Comeo G, 1~230 V, 50 Hz.....	8
Comeo G, 1~230 V, 60 Hz.....	8
Comeo G, 230/400 V, 50 Hz	9
Comeo G, 230/400 V, 60 Hz	9
Characteristic curves.....	10
n ≈ 2900 rpm.....	10
Comeo; 2; n ≈ 2900 rpm.....	10
Comeo; 4; n ≈ 2900 rpm.....	11
Comeo; 6; n ≈ 2900 rpm.....	12
n ≈ 3500 rpm.....	13
Comeo; 2; n ≈ 3500 rpm.....	13
Comeo; 4; n ≈ 3500 rpm.....	14
Comeo; 6; n ≈ 3500 rpm.....	15
Dimensions and connections	16
Dimensions	16
Connections.....	17
General assembly drawing with list of components.....	18
Detailed designation.....	19

Centrifugal Pumps

Multistage Horizontal Centrifugal Pumps

Comeo



Main applications

- Cold water pressure booster systems
- Cold water systems
- General irrigation systems
- Light industrial applications

Fluids handled

- Clean water (without solids)
- Slightly aggressive fluid

Operating data

Operating properties

Characteristic		Value
Flow rate	Q [m ³ /h]	≤ 10,8
Head	H [m]	≤ 79,5
Fluid temperature	T [°C]	-10 to +60
Ambient temperature	T [°C]	-20 to +40 ¹⁾
Pressure class	PN [bar]	10

Designation

Example: Como C 2/2

Designation key

Code	Description
Comeo	Type series
C	Material variant
C	Pump casing made of cast stainless steel
G	Pump casing made of cast iron

1) Optional: -20 to +55 °C
 2) Default: stages 2, 4 und 6; optional: intermediate stages 1, 3 and 5

Code	Description
2	Size, flow rate [m ³ /h] at BEP
	2, 4, 6
2	Number of stages ²⁾

Design details

Design

- Centrifugal pump
- Multistage
- Close-coupled design
- Extended motor shaft
- Maximum pressure class PN 10

Installation

- Horizontal installation

Drive

- Single-phase AC motor or three-phase motor
- To IEC 60034-7
- Efficiency class IE3 to IEC 60034-30 (for three-phase motors ≥ 0.75 kW)
- Frequency 50/60 Hz
- 2 poles
- Thermal class F
- IP55 enclosure
- Duty cycle: continuous duty S1
- Thermal circuit breaker with automatic reset and start-up for single-phase AC motor

Shaft seal

- Mechanical seal
- To EN 12756
- Uncooled
- Maintenance-free

Materials

Overview of materials depending on material variant

Part No.	Description	In contact with water	Comeo C	Comeo G
10-6	Pump shroud	X	1.4301	
101	Pump casing	X	1.4308	EN-GJL-250
108.01/04/05	Stage casing	X	1.4301	
160	Cover	X	1.4301	
-	Shaft	X	1.4541	
230	Impeller	X	1.4301	
341	Drive lantern	-	EN-GJL-250	
412	O-ring	X	EPDM	
433	Mechanical seal	X	B V E F F	B V P F F
525.01/03/05	Spacer sleeve	X	1.4305	
903.05	Vent plug	X	1.4301 / EPDM	PEHD / TPE
905	Tie bolt	-	1.4057	
920.02/03	Nut	X	1.4301	
930.02	Lock washer	X	1.4401	
932	Circlip	X	1.4571	
950	Spring	X	1.4401	

Comparison of materials

EN	General description	EN material code	EN standard	ASTM
EN-GJL-250	Cast iron	GJL-250	EN 1561	A48 - 40 B
1.4057	Chrome nickel steel	X17CrNi 16-2--QT800	EN 10088-3	A276 - 431
1.4301	Chrome nickel steel	X5CrNi 18-10	EN 10088	A276 - 304
1.4305	Chrome nickel steel	X8CrNiS 18-9	EN 10088	A276 - 303
1.4308	Chrome nickel steel	GX5CrNi19-10	EN 10213-4	A351 - Grade CF8
1.4401	Chrome nickel molybdenum steel	X5CrNiMo 17-12-2	EN 10088	A276 - 316
1.4541	Chrome nickel steel	X6CrNiMoTi 18-10	EN 10088	A276 - 321
1.4571	Chrome nickel molybdenum steel	X6CrNiMoTi 17-12-2	EN 10088	A276 - 316Ti

Product benefits



- Top quality pump thanks to advanced high-precision production technology and resistant high-grade materials
- An energy-saving, state-of-the-art pump solution characterised by high efficiency levels, optimum flow passage, the use of high-efficiency motors, and precision engineering of all hydraulic components
- High energy efficiency as well as low investment and maintenance costs make for low life cycle costs
- Very compact, space-saving design

Minimum flow rate / maximum flow rate Q [m³/h] at a fluid temperature ≤ 20 °C

Size	50 Hz		60 Hz	
	Min.	Max.	Min.	Max.
2	0,2	3,3	0,2	4,0
4	0,4	6,5	0,5	7,8
6	0,6	9,0	0,8	10,8

Certifications

Overview

Label	Valid in:	Note
	France	For material variant cast stainless steel
	United Kingdom	For material variant cast stainless steel

Selection information

Minimum flow rate / maximum flow rate

A minimum flow rate must be ensured to protect the pump against overheating and to prevent gas pockets, cavitation, etc.

Overview of product features / selection tables

Shaft seal

Mechanical seal material – Comeo C

Code to EN 12756	Description	Material	Code	Comment
B	Primary ring	Carbon graphite	Ca	Resin-impregnated
V	Mating ring	Aluminium oxide	Ce	Ceramics
E	Elastomer	EPDM	EPDM	Ethylene propylene rubber ³⁾
F	Spring	Chrome nickel steel	CrNi steel	-
F	Other metal parts	Chrome nickel steel	CrNi steel	-

Mechanical seal material – Comeo G

Code to EN 12756	Description	Material	Code	Comment
B	Primary ring	Carbon graphite	Ca	Resin-impregnated
V	Mating ring	Aluminium oxide	Ce	Ceramics
P	Elastomer	NBR	NBR	Nitrile butadiene rubber
F	Spring	Chrome nickel steel	CrNi steel	-
F	Other metal parts	Chrome nickel steel	CrNi steel	-

3) To ACS / WRAS

Technical data
Comeo C, 1~230 V, 50 Hz

50 Hz

Size	n	P _N	I _A /I _N	cos φ	U _N	η	L _p	Cable gland	Maximum frequency of starts	I _N	Mat. No.	[kg]
	[rpm]	[kW]	Tolerance		[h ⁻¹]					1~230 V		
										[A]		
2/2	2750	0,37	3,70	0,92	+/-10	67,00	58,00	1 × M18 × 1,5	20	2,60	48229175	13,1
2/4	2750	0,37	3,70	0,92	+/-10	67,00	58,00	1 × M18 × 1,5	20	2,60	48229176	13,8
2/6	2760	0,55	3,90	0,92	+/-10	70,00	56,00	1 × M18 × 1,5	20	3,69	48229177	15,9
4/2	2750	0,37	3,70	0,92	+/-10	67,00	58,00	1 × M18 × 1,5	20	2,60	48229178	13,1
4/4	2760	0,55	3,90	0,92	+/-10	70,00	56,00	1 × M18 × 1,5	20	3,69	48229179	15,3
4/6	2790	1,10	4,30	0,95	+/-10	75,00	58,00	1 × M20 × 1,5	20	6,68	48229180	20
6/2	2750	0,37	3,70	0,92	+/-10	67,00	58,00	1 × M18 × 1,5	20	2,60	48239930	13,4
6/4	2790	1,10	4,30	0,95	+/-10	75,00	58,00	1 × M20 × 1,5	20	6,68	48239931	19,7
6/6	2800	1,50	4,80	0,95	+/-10	76,00	58,00	1 × M20 × 1,5	20	8,99	48239932	23,1

Comeo C, 1~230 V, 60 Hz

60 Hz

Size	n	P _N	I _A /I _N	cos φ	U _N	η	L _p	Cable gland	Maximum frequency of starts	I _N	Mat. No.	[kg]
	[rpm]	[kW]	Tolerance		[h ⁻¹]					1~230 V		
										[A]		
2/2	3450	0,37	4,50	0,95	+/-10	74,00	64,00	1 × M18 × 1,5	20	2,30	48239933	13,1
2/4	3420	0,55	3,80	0,96	+/-10	74,00	65,00	1 × M18 × 1,5	20	3,35	48239934	15,2
2/6	3420	0,75	4,30	0,97	+/-10	75,00	68,00	1 × M20 × 1,5	20	4,50	48239935	17,4
4/2	3420	0,55	3,80	0,96	+/-10	74,00	65,00	1 × M18 × 1,5	20	3,35	48239936	14,5
4/4	3400	1,10	4,80	0,96	+/-10	79,00	72,00	1 × M20 × 1,5	20	6,30	48239937	19,3
4/6	3420	1,50	4,70	0,95	+/-10	76,00	75,00	1 × M20 × 1,5	20	9,10	48239938	22,7
6/2	3420	0,75	4,30	0,97	+/-10	75,00	68,00	1 × M20 × 1,5	20	4,50	48239939	16,3
6/4	3420	1,50	4,70	0,95	+/-10	76,00	75,00	1 × M20 × 1,5	20	9,10	48239940	22,4
6/6	3420	2,20	4,50	0,95	+/-10	77,00	78,00	1 × M20 × 1,5	20	13,10	48239941	25,1

Comeo C, 230/400 V, 50 Hz

50 Hz

Size	n	P _N	I _A /I _N	cos φ	U _N	η	L _p	Cable gland	Maximum frequency of starts	I _N	Mat. No.	[kg]
	[rpm]	[kW]	Tolerance		[h ⁻¹]					230/400 V		
										[A]		
2/2	2750	0,37	4,60	0,78	+/-10	74,20	58,00	1 × M20 × 1,5	20	1,64/0,94	48239960	13,1
2/4	2750	0,37	4,60	0,78	+/-10	74,20	58,00	1 × M20 × 1,5	20	1,64/0,94	48239961	13,8
2/6	2790	0,55	5,20	0,75	+/-10	77,60	58,00	1 × M20 × 1,5	20	2,31/1,33	48239962	15,9
4/2	2750	0,37	4,60	0,78	+/-10	74,20	58,00	1 × M20 × 1,5	20	1,64/0,94	48239963	13,1
4/4	2790	0,55	5,20	0,75	+/-10	77,60	58,00	1 × M20 × 1,5	20	2,31/1,33	48239964	15,3
4/6	2855	1,10	7,00	0,80	+/-10	82,70	60,00	2 × M20 × 1,5	25	4,22/2,43	48256815	20
6/2	2750	0,37	4,60	0,78	+/-10	74,20	58,00	1 × M20 × 1,5	20	1,64/0,94	48239966	13,4
6/4	2855	1,10	7,00	0,80	+/-10	82,70	60,00	2 × M20 × 1,5	25	4,22/2,43	48256816	19,7
6/6	2900	1,50	7,70	0,88	+/-10	84,20	63,00	2 × M25 × 1,5	25	5,08/2,92	48256817	23,1

Comeo C, 230/400 V, 60 Hz

60 Hz

Size	n	P _N	I _A /I _N	cos φ	U _N	η	L _p	Cable gland	Maximum frequency of starts	I _N	Mat. No.	[kg]
					Tolerance					230/400 V		
	[rpm]	[kW]	[%]	[%]	[dB]	[h ⁻¹]	[A]					
2/2	3300	0,37	3,90	0,78	+20/-5	75,70	58,00	1 × M20 × 1,5	20	1,54/0,89	48239969	13,1
2/4	3345	0,55	4,40	0,75	+20/-5	77,60	56,00	1 × M20 × 1,5	20	2,29/1,32	48239970	15,2
2/6	3440	0,75	6,50	0,80	+20/-5	80,90	60,00	2 × M20 × 1,5	25	2,87/1,65	48256818	17,4
4/2	3345	0,55	4,40	0,75	+20/-5	77,60	56,00	1 × M20 × 1,5	20	2,29/1,32	48239972	14,5
4/4	3440	1,10	6,70	0,81	+20/-5	82,90	60,00	2 × M20 × 1,5	25	4,72/2,72	48256819	19,3
4/6	3500	1,50	6,70	0,89	+20/-5	84,4	66,00	2 × M25 × 1,5	25	5,01/2,88	48256820	22,7
6/2	3440	0,75	6,50	0,80	+20/-5	80,90	60,00	2 × M20 × 1,5	25	2,87/1,65	48256821	16,3
6/4	3500	1,50	6,70	0,89	+20/-5	84,4	66,00	2 × M25 × 1,5	25	5,01/2,88	48256822	22,4
6/6	3500	2,20	6,70	0,90	+20/-5	86,10	66,00	1 × M25 × 1,5	25	7,12/4,09	48256823	25,1

Comeo G, 1~230 V, 50 Hz

50 Hz

Size	n	P _N	I _A /I _N	cos φ	U _N	η	L _p	Cable gland	Maximum frequency of starts	I _N	Mat. No.	[kg]
					Tolerance					1~230 V		
	[rpm]	[kW]	[%]	[%]	[dB]	[h ⁻¹]	[A]					
2/2	2750	0,37	3,70	0,92	+/-10	67,00	58,00	1 × M18 × 1,5	20	2,60	48229157	13,1
2/4	2750	0,37	3,70	0,92	+/-10	67,00	58,00	1 × M18 × 1,5	20	2,60	48229158	13,8
2/6	2760	0,55	3,90	0,92	+/-10	70,00	56,00	1 × M18 × 1,5	20	3,69	48229159	15,9
4/2	2750	0,37	3,70	0,92	+/-10	67,00	58,00	1 × M18 × 1,5	20	2,60	48229160	13,1
4/4	2760	0,55	3,90	0,92	+/-10	70,00	56,00	1 × M18 × 1,5	20	3,69	48229161	15,3
4/6	2790	1,10	4,30	0,95	+/-10	75,00	58,00	1 × M20 × 1,5	20	6,68	48229162	20
6/2	2750	0,37	3,70	0,92	+/-10	67,00	58,00	1 × M18 × 1,5	20	2,60	48229163	13,4
6/4	2790	1,10	4,30	0,95	+/-10	75,00	58,00	1 × M20 × 1,5	20	6,68	48229164	19,7
6/6	2800	1,50	4,80	0,95	+/-10	76,00	58,00	1 × M20 × 1,5	20	8,99	48229165	23,1

Comeo G, 1~230 V, 60 Hz

60 Hz

Size	n	P _N	I _A /I _N	cos φ	U _N	η	L _p	Cable gland	Maximum frequency of starts	I _N	Mat. No.	[kg]
					Tolerance					1~230 V		
	[rpm]	[kW]	[%]	[%]	[dB]	[h ⁻¹]	[A]					
2/2	3450	0,37	4,50	0,95	+/-10	74,00	64,00	1 × M18 × 1,5	20	2,30	48229166	13,1
2/4	3420	0,55	3,80	0,96	+/-10	74,00	65,00	1 × M18 × 1,5	20	3,35	48229167	15,2
2/6	3420	0,75	4,30	0,97	+/-10	75,00	68,00	1 × M20 × 1,5	20	4,50	48229168	17,4
4/2	3420	0,55	3,80	0,96	+/-10	74,00	65,00	1 × M18 × 1,5	20	3,35	48229169	14,5
4/4	3400	1,10	4,80	0,96	+/-10	79,00	72,00	1 × M20 × 1,5	20	6,30	48229170	19,3
4/6	3420	1,50	4,70	0,95	+/-10	76,00	75,00	1 × M20 × 1,5	20	9,10	48229171	22,7
6/2	3420	0,75	4,30	0,97	+/-10	75,00	68,00	1 × M20 × 1,5	20	4,50	48229172	16,3
6/4	3420	1,50	4,70	0,95	+/-10	76,00	75,00	1 × M20 × 1,5	20	9,10	48229173	22,4
6/6	3420	2,20	4,50	0,95	+/-10	77,00	78,00	1 × M20 × 1,5	20	13,10	48229174	25,1

Comeo G, 230/400 V, 50 Hz

50 Hz

Size	n [rpm]	P _N [kW]	I _A /I _N	cos φ	U _N	η	L _p [dB]	Cable gland	Maximum frequency of starts [h ⁻¹]	I _N	Mat. No.	[kg]
					Tolerance					230/400 V		
	[%]	[A]										
2/2	2750	0,37	4,60	0,78	+/-10	74,20	58,00	1 × M20 × 1,5	20	1,64/0,94	48239942	13,1
2/4	2750	0,37	4,60	0,78	+/-10	74,20	58,00	1 × M20 × 1,5	20	1,64/0,94	48239943	13,8
2/6	2790	0,55	5,20	0,75	+/-10	77,60	58,00	1 × M20 × 1,5	20	2,31/1,33	48239944	15,9
4/2	2750	0,37	4,60	0,78	+/-10	74,20	58,00	1 × M20 × 1,5	20	1,64/0,94	48239945	13,1
4/4	2790	0,55	5,20	0,75	+/-10	77,60	58,00	1 × M20 × 1,5	20	2,31/1,33	48239946	15,3
4/6	2855	1,10	7,00	0,80	+/-10	82,70	60,00	2 × M20 × 1,5	25	4,22/2,43	48256806	20
6/2	2750	0,37	4,60	0,78	+/-10	74,20	58,00	1 × M20 × 1,5	20	1,64/0,94	48239948	13,4
6/4	2855	1,10	7,00	0,80	+/-10	82,70	60,00	2 × M20 × 1,5	25	4,22/2,43	48256807	19,7
6/6	2900	1,50	7,70	0,88	+/-10	84,20	63,00	2 × M25 × 1,5	25	5,08/2,92	48256808	23,1

Comeo G, 230/400 V, 60 Hz

60 Hz

Size	n [rpm]	P _N [kW]	I _A /I _N	cos φ	U _N	η	L _p [dB]	Cable gland	Maximum frequency of starts [h ⁻¹]	I _N	Mat. No.	[kg]
					Tolerance					230/400 V		
	[%]	[A]										
2/2	3300	0,37	3,90	0,78	+20/-5	75,70	58,00	1 × M20 × 1,5	20	1,54/0,89	48239951	13,1
2/4	3345	0,55	4,40	0,75	+20/-5	77,60	56,00	1 × M20 × 1,5	20	2,29/1,32	48239952	15,2
2/6	3440	0,75	6,50	0,80	+20/-5	80,90	60,00	2 × M20 × 1,5	25	2,87/1,65	48256809	17,4
4/2	3345	0,55	4,40	0,75	+20/-5	77,60	56,00	1 × M20 × 1,5	20	2,29/1,32	48239954	14,5
4/4	3440	1,10	6,70	0,81	+20/-5	82,90	60,00	2 × M20 × 1,5	25	4,72/2,72	48256810	19,3
4/6	3500	1,50	6,70	0,89	+20/-5	84,4	66,00	2 × M25 × 1,5	25	5,01/2,88	48256811	22,7
6/2	3440	0,75	6,50	0,80	+20/-5	80,90	60,00	2 × M20 × 1,5	25	2,87/1,65	48256812	16,3
6/4	3500	1,50	6,70	0,89	+20/-5	84,4	66,00	2 × M25 × 1,5	25	5,01/2,88	48256813	22,4
6/6	3500	2,20	6,70	0,90	+20/-5	86,10	66,00	1 × M25 × 1,5	25	7,12/4,09	48256814	25,1

Characteristic curves

$n \approx 2900$ rpm

Comeo; 2; $n \approx 2900$ rpm

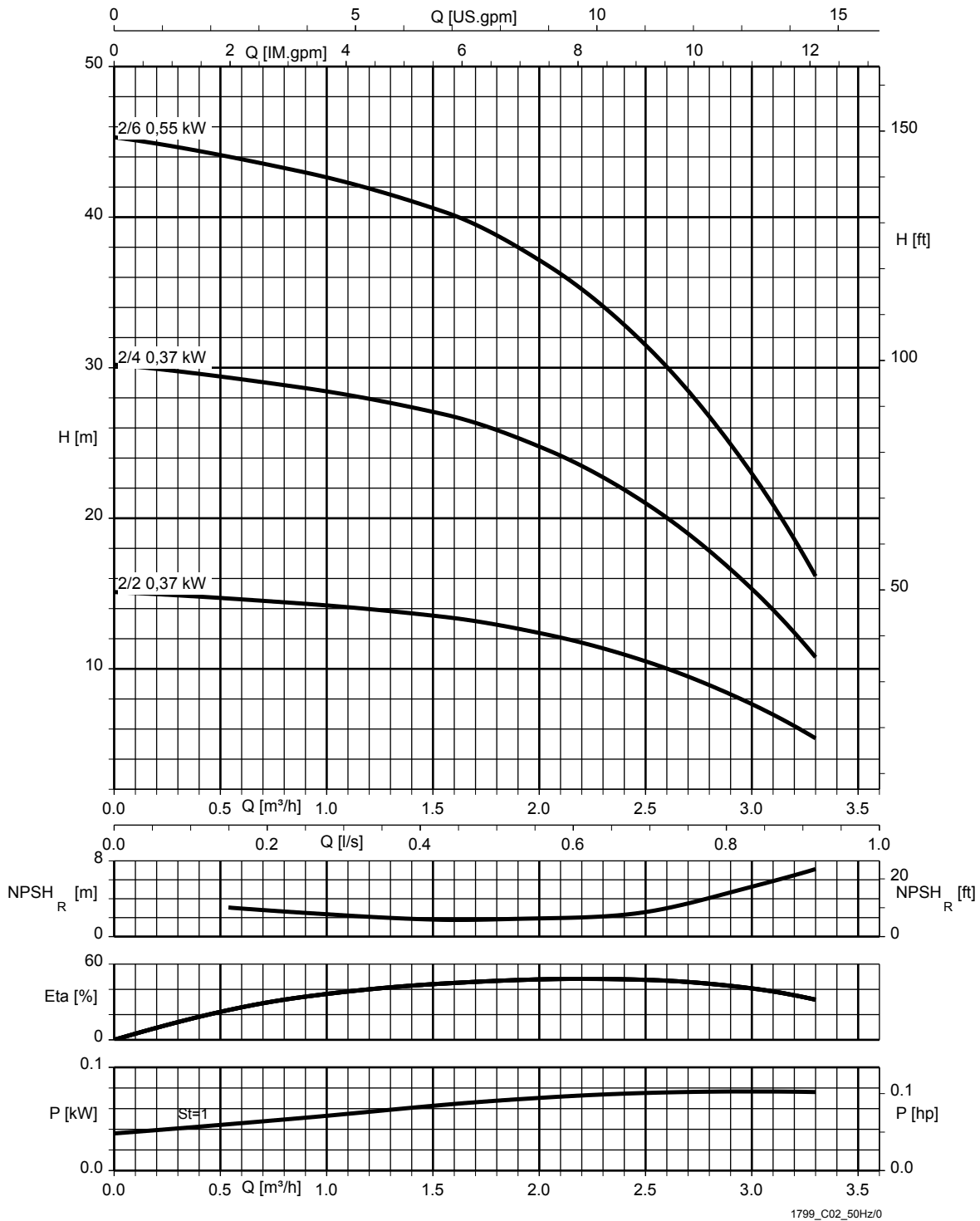

1799_C02_50Hz/0

St = 1 | P per stage

Comeo; 4; n ≈ 2900 rpm

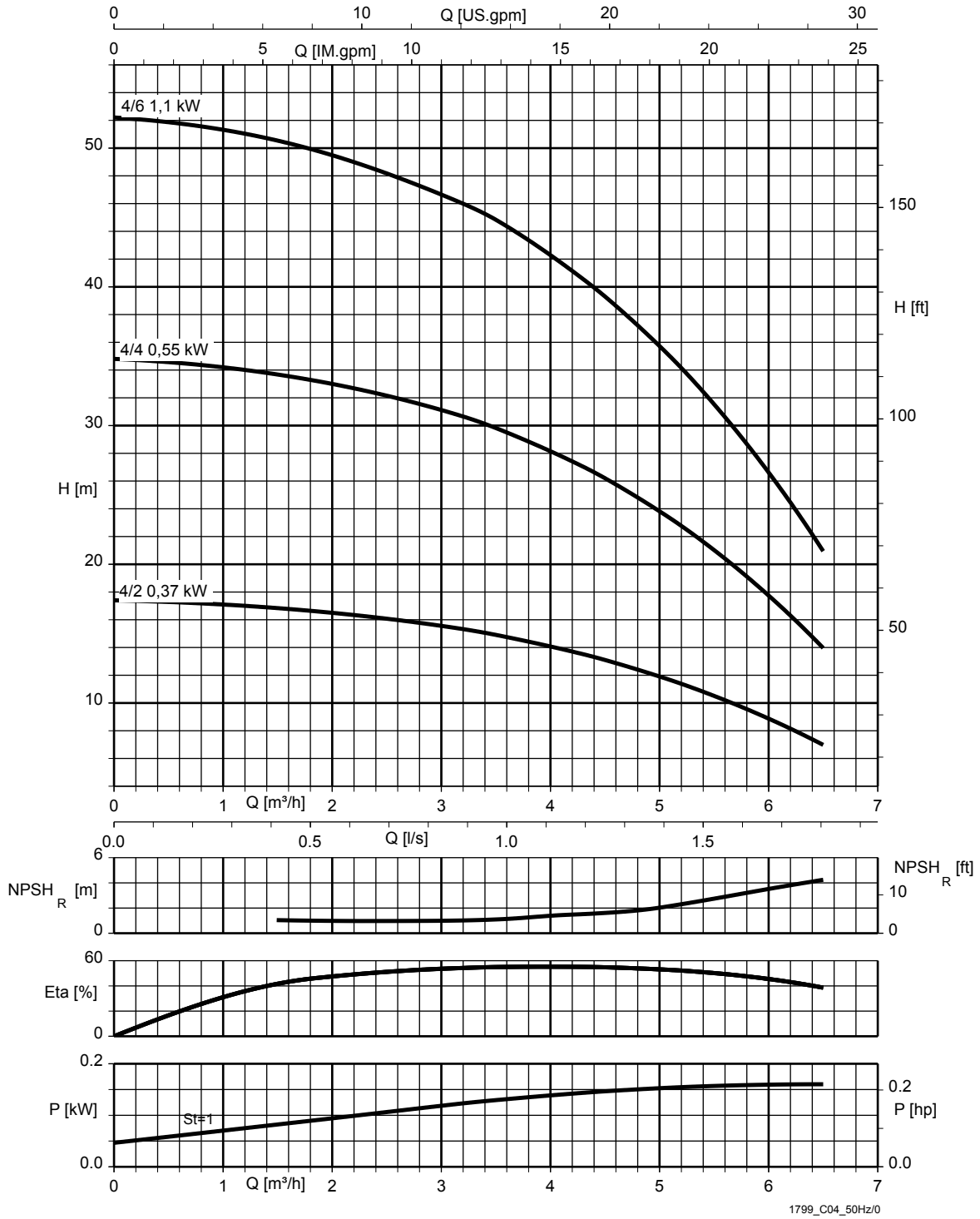

St = 1 | P per stage

Comeo; 6; n ≈ 2900 rpm

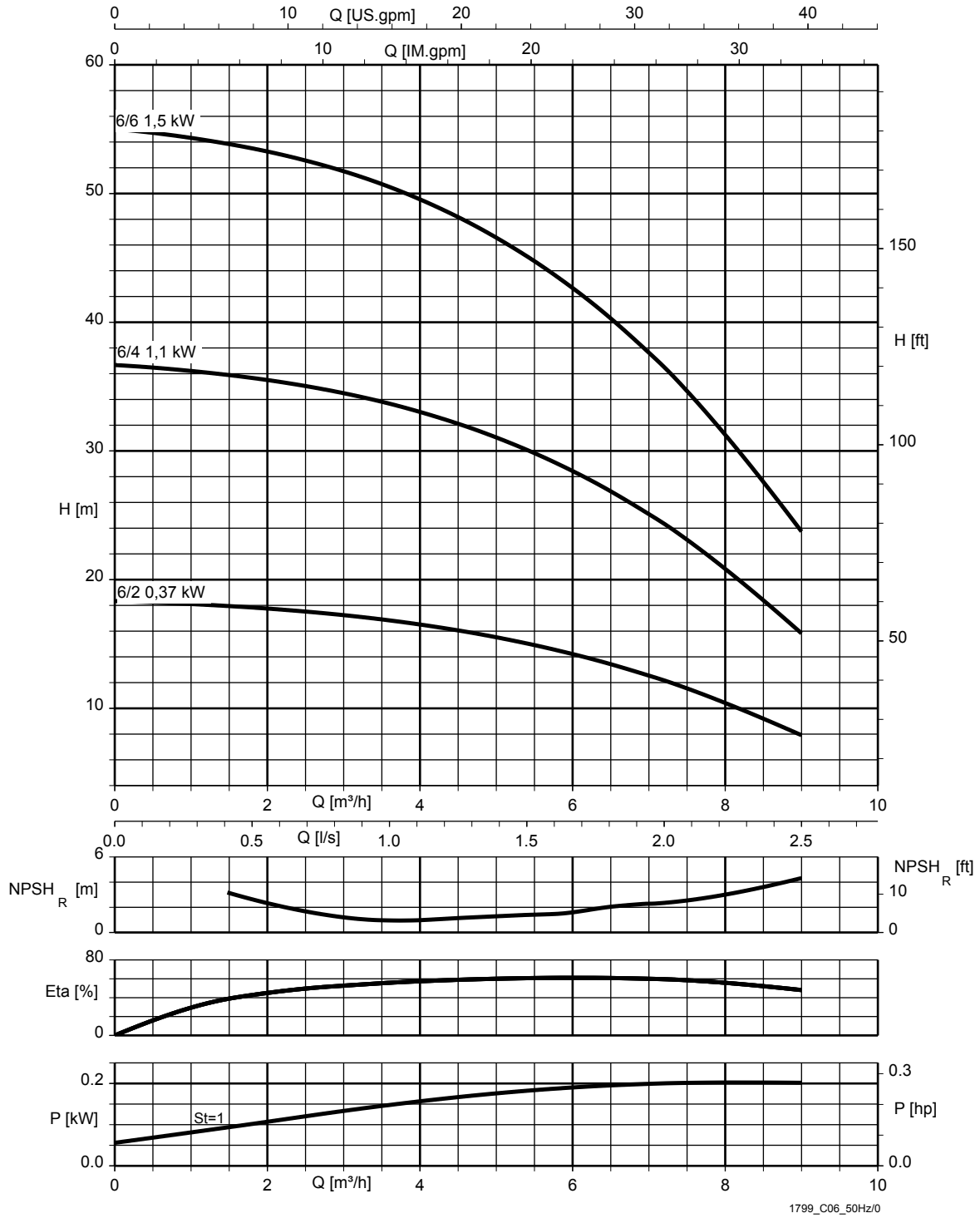

St = 1 | P per stage

$n \approx 3500$ rpm

Comeo; 2; $n \approx 3500$ rpm

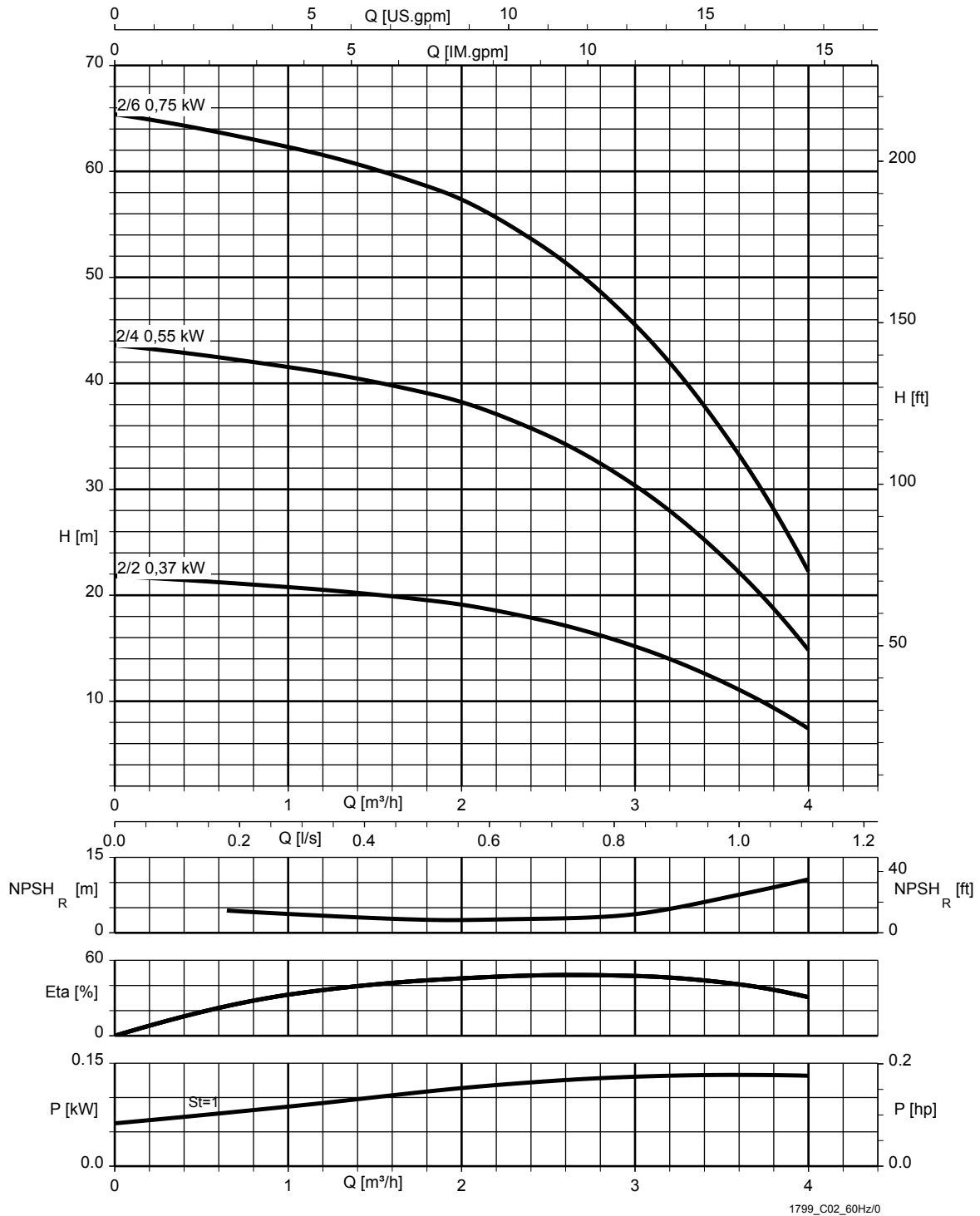

St = 1 P per stage

Comeo; 4; $n \approx 3500$ rpm

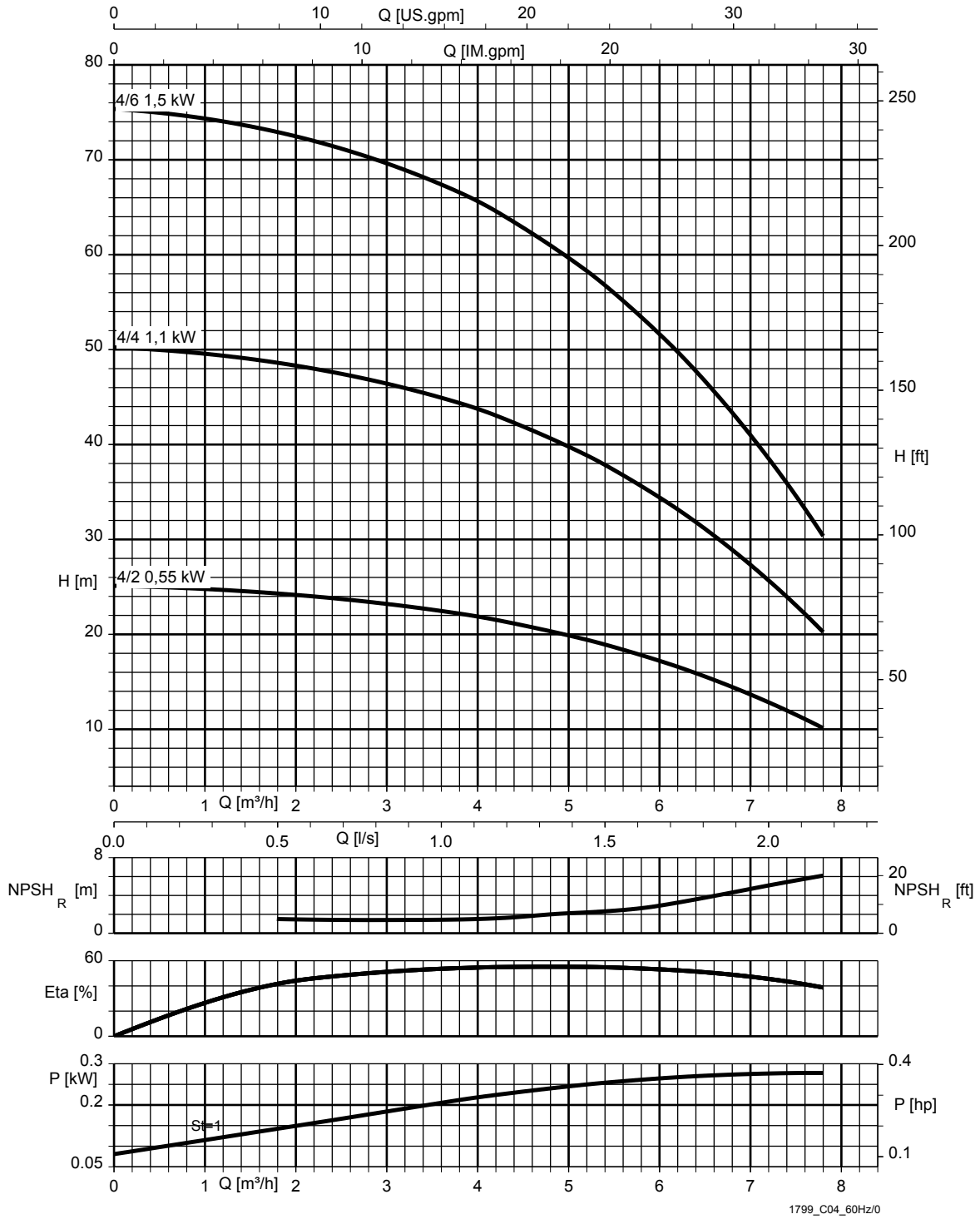

St = 1 | P per stage

Comeo; 6; n ≈ 3500 rpm

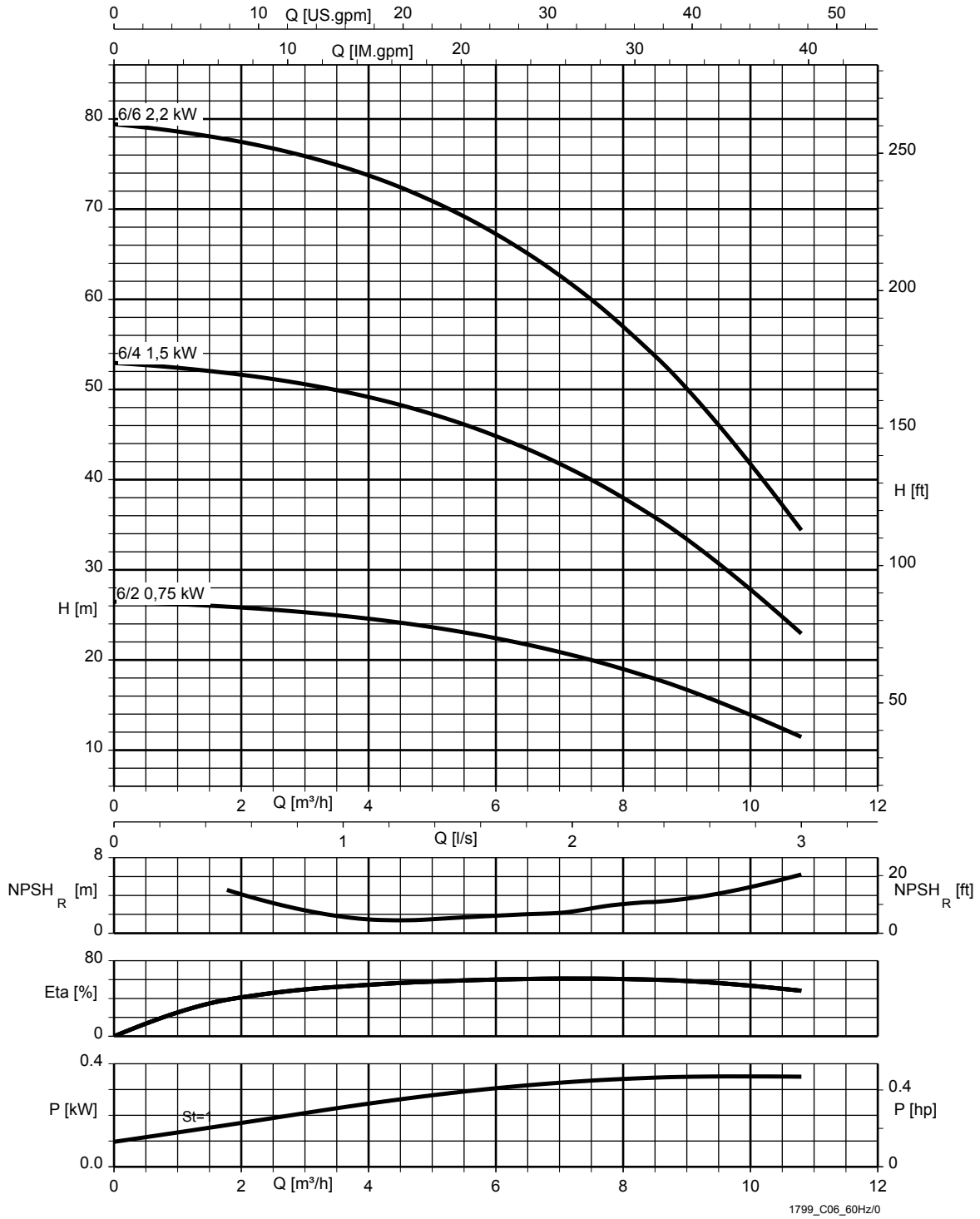

St = 1 | P per stage

Dimensions and connections

Dimensions

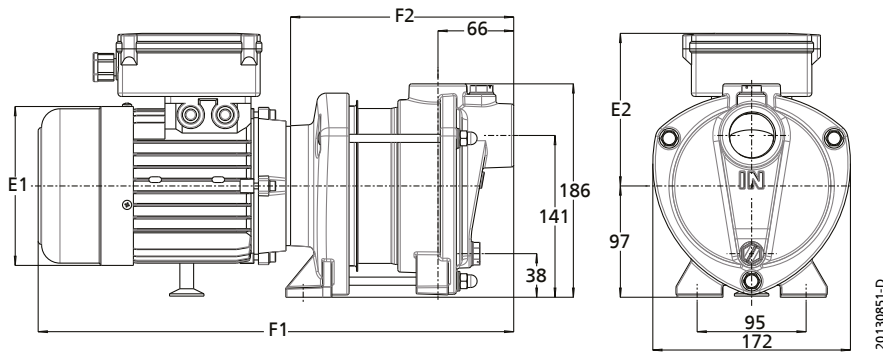

Fig. 1: Dimensions [mm]

Dimensions, 1~230 V, 50 Hz

Size	P _N [kW]	E1 [mm]	E2 [mm]	F1 [mm]	F2 [mm]
2/2	0,37	138,50	110,00	372,50	151,50
2/4	0,37	138,50	110,00	405,00	184,00
2/6	0,55	138,50	110,00	448,00	227,00
4/2	0,37	138,50	110,00	372,50	151,50
4/4	0,55	138,50	110,00	405,00	184,00
4/6	1,10	159,00	155,00	473,00	227,00
6/2	0,37	138,50	110,00	372,50	151,50
6/4	1,10	159,00	155,00	440,50	194,50
6/6	1,50	176,50	160,00	529,50	244,50

Dimensions, 1~230 V, 60 Hz

Size	P _N [kW]	E1 [mm]	E2 [mm]	F1 [mm]	F2 [mm]
2/2	0,37	138,50	110,00	372,50	151,50
2/4	0,55	138,50	110,00	405,00	184,00
2/6	0,75	159,00	155,00	473,00	227,00
4/2	0,55	138,50	110,00	372,50	151,50
4/4	1,10	159,00	155,00	430,00	184,00
4/6	1,50	176,50	160,00	512,00	227,00
6/2	0,75	159,00	155,00	397,50	151,50
6/4	1,50	176,50	160,00	479,50	194,50
6/6	2,20	176,50	160,00	529,50	244,50

Dimensions, 230/400 V, 50 Hz

Size	P _N [kW]	E1 [mm]	E2 [mm]	F1 [mm]	F2 [mm]
2/2	0,37	138,00	109,00	372,50	151,50
2/4	0,37	138,00	109,00	405,00	184,00
2/6	0,55	138,00	109,00	448,00	227,00
4/2	0,37	138,00	109,00	372,50	151,50
4/4	0,55	138,00	109,00	405,00	184,00
4/6	1,10	157,00	133,00	487,00	227,00
6/2	0,37	138,00	109,00	372,50	151,50
6/4	1,10	157,00	133,00	454,50	194,50
6/6	1,50	180,00	145,00	497,50	244,50

Dimensions, 230/400 V, 60 Hz

Size	P _N	E1	E2	F1	F2
	[kW]	[mm]	[mm]	[mm]	[mm]
2/2	0,37	138,00	109,00	372,50	151,50
2/4	0,55	138,00	109,00	405,00	184,00
2/6	0,75	157,00	133,00	484,00	227,00
4/2	0,55	138,00	109,00	372,50	151,50
4/4	1,10	157,00	133,00	444,00	184,00
4/6	1,50	180,00	145,00	480,00	227,00
6/2	0,75	157,00	133,00	408,50	151,50
6/4	1,50	180,00	145,00	447,50	194,50
6/6	2,20	180,00	145,00	529,50	244,50

Connections

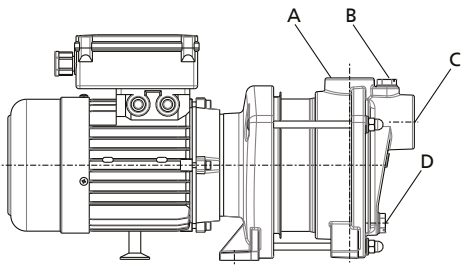

Fig. 2: Connections

A	Discharge nozzle (G 1), internal thread	C	Suction nozzle (G 1 1/4), internal thread
B	Screw filler plug (G 1/4)	D	Screw drain plug (G 1/4)

General assembly drawing with list of components

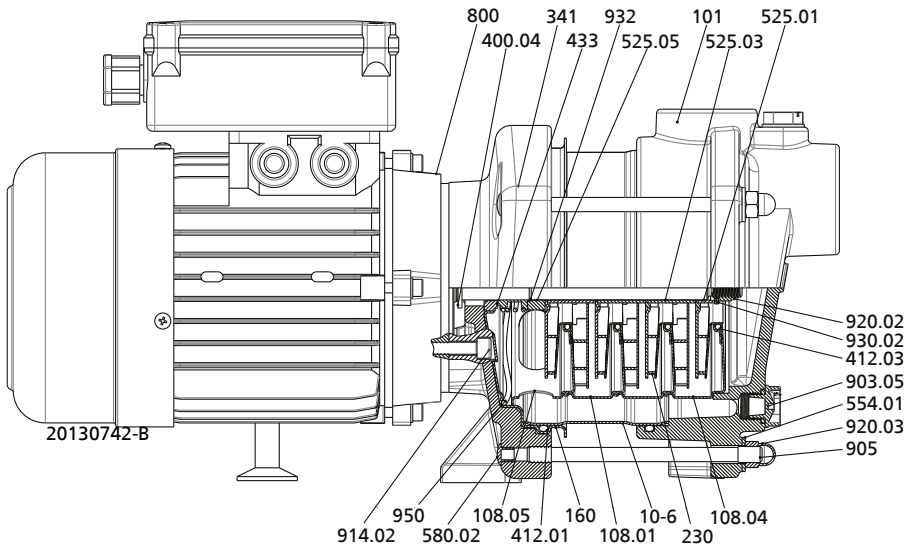

Fig. 3: General assembly drawing

List of components

Part No.	Description	Part No.	Description
10-6	Pump shroud	554.01	Washer
101	Pump casing	580.02	Cap
108.01/.04/.05	Stage casing	800	Motor
160	Cover	903.05	Screw plug
230	Impeller	905	Tie bolt
341	Drive lantern	914.02	Hexagon socket head cap screw
400.04	Gasket	920.02/.03	Nut
412.01/.03	O-ring	930.02	Safety device
433	Mechanical seal	932	Circlip
525.01/.03/.05	Spacer sleeve	950	Spring

Detailed designation

Designation example

Position																															
1	2	3	4	5	6	7	8	9	10	11	12	13	14	15	16	17	18	19	20	21	22	23	24	25	26	27	28	29	30	31	32
C	o	m	e	o			C		I	0	0	4	/	0	6	-	A	4	B	3	2	F	S	0	9	0	E	5	M	W	
See name plate and data sheet																See data sheet															

Position 1-7: designation

Code	Description
Comeo	Comeo

Position 8-9: design

Code	Description
C	1.4308 (casing) / 1.4301 (hydraulic system)
G	EN-GJL-250 (casing) / 1.4301 (hydraulic system)

Position 10: connection type

Code	Description
I	Internal thread

Position 11-13: size

Code	Description
002	Size 2
004	Size 4
006	Size 6

Position 15-16: number of stages

Code	Description
01	1 stage
02	2 stages
03	3 stages
04	4 stages
05	5 stages
06	6 stages

Position 17: trimmed impellers

Code	Description
-	No trimmed impeller

Position 18: generation

Code	Description
A	Generation from 2015

Position 19: standard of connection

Code	Description
4	Internal thread / EN ISO 228-1

Position 20: material variant

Code	Description
A	EN-GJL-250 (casing) / 1.4301 (hydraulic system)
B	1.4308 (casing) / 1.4301 (hydraulic system)

Position 21-22: seal code

Code	Description
31	B V P F F
32	B V E F F

Position 23: mechanical seal design

Code	Description
F	"Fixed" design

Position 24: drive

Code	Description
S	Standard IEC

Position 25-27: motor rating and number of poles

Code	Description
071	IEC 071
080	IEC 080
090	IEC 090

Position 28: pressure class

Code	Description
E	PN10

Position 29: mains frequency

Code	Description
5	50 Hz, 2-pole
6	60 Hz, 2-pole

Position 30: motor specification

Code	Description
C	230/400 V, three-phase motor (IE2)
M	230 V, single-phase AC motor
O	0.37/0.55 kW non-classified
U	230/400 V, three-phase motor (IE3)

Position 31: PumpMeter

Code	Description
W	Without PumpMeter

Position 32: standard design

Code	Description
X	One or several non-standard components



KSB SE & Co. KGaA
Johann-Klein-Straße 9 • 67227 Frankenthal (Germany)
Tel. +49 6233 86-0
www.ksb.com