

Self-priming Pump

Etaprime L

Type Series Booklet



Legal information/Copyright

Type Series Booklet Etaprime L

All rights reserved. The contents provided herein must neither be distributed, copied, reproduced, edited or processed for any other purpose, nor otherwise transmitted, published or made available to a third party without the manufacturer's express written consent.

Subject to technical modification without prior notice.

© KSB Aktiengesellschaft, Frankenthal 01/12/2017

Contents

Self-priming Pump	4
Volute Casing Pumps	4
Etaprime L	4
Main applications	4
Fluids handled	4
Operating data	4
Design details	4
Designation	5
Materials	6
Product benefits	6
Certifications	6
Overview of product features / selection tables	7
Overview of fluids handled	7
Overview of type series	8
Bearings	8
Selection Information	8
Priming time	8
Pressure limits	10
Selection Charts	11
Etaprime L / Etaprime B, n = 2900 rpm (* also available in stainless steel material variant)	11
Etaprime L / Etaprime B, n = 1450 rpm (* also available in stainless steel material variant)	12
Etaprime L / Etaprime B, n = 3500 rpm (* also available in stainless steel material variant)	13
Etaprime L / Etaprime B, n = 1750 rpm (* also available in stainless steel material variant)	14
Dimensions and connections	15
Etaprime L 025-025-100 to 040-040-110 (shaft unit 17) – pump	15
Etaprime L 025-025-100 to 040-040-110 (shaft unit 17) – pump set	16
Etaprime L 040-040-140 to 125-125-260 (shaft units 25/35) – pump	17
Etaprime L 040-040-140 to 125-125-260 (shaft units 25/35) – pump set with coupling	19
Etaprime L 040-040-140 to 125-125-260 (shaft units 25/35) – pump set with spacer-type coupling	21
Flange designs	23
Interchangeability of Etaprime L and Etaprime B pump components	24
Scope of supply	24
General assembly drawings with list of components	25
Etaprime G and C, threaded connection, with bearing housing (SU 17)	25
Etaprime G and C, flanged connection, with bearing bracket/grease lubrication (SU 25 and SU 35)	27
Etaprime G and C, flanged connection, with bearing bracket/oil lubrication (SU 25 and SU 35)	30

Self-priming Pump

Volute Casing Pumps

Etaprime L

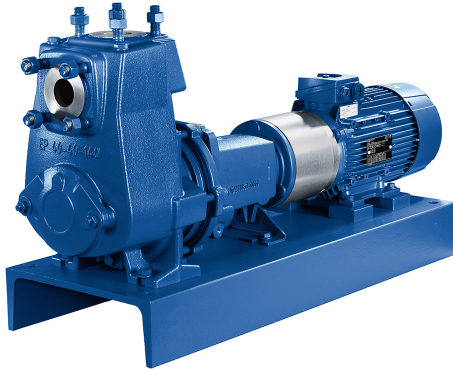

Main applications

- Spray irrigation systems
- Service water supply systems
- Drainage
- Drainage systems
- Fire-fighting systems
- Lowering groundwater levels
- Domestic water supply
- Air-conditioning systems
- Cooling circuits
- Swimming pools
- Water supply systems

Fluids handled

- Drinking water
- Swimming pool water¹⁾
- Fire-fighting water
- Seawater
- River water
- Lake water
- Groundwater
- Brackish water
- Condensate
- Brine
- Oil

- Service water
- Cleaning agents
- Cooling water

Operating data

Operating properties

Characteristic		Value	
		50 Hz	60 Hz
Flow rate	Q [m ³ /h]	≤ 180	≤ 150
	Q [l/s]	≤ 50	≤ 41
Head	H [m]	≤ 85	≤ 105
Fluid temperature	T [°C]	≥ -30	≥ -30
		≤ +90	≤ +90
Operating pressure	p [bar]	≤ 10	≤ 10
Static suction lift	H _{Geo} [m]	≤ 9	≤ 9

Design details

Design

- Volute casing pump
- Back pull-out design (from size 40-40-140)
- Horizontal installation
- Self-priming
- Single-stage
- Single-entry

Pump casing

- Radially split volute casing
- Volute casing with integrally cast pump feet (from pump size 40-40-140)

Drive

- KSB IEC frame standardised IE3 motor (from 0.75 kW)
- 230/400 V up to 2.2 kW and 400/690 V from 3 kW
- Winding 60 Hz, 3~ 440 - 480 V ≥ 2.41 hp (1.80 kW)
- Type of construction B3
- Enclosure IP55
- Thermal class F with temperature sensor, 3 PTC thermistors
- Duty cycle: continuous duty S1

Shaft seal

- The shaft is fitted with a replaceable shaft sleeve in the shaft seal area (from pump size 40-40-140).
- Single mechanical seals and double mechanical seals to EN 12756

Impeller type

- Open multi-vane impeller

Bearings

- Various application-oriented bearings (⇒ Page 8)

1) Swimming pool water (0.4 to 1.4 mg/l free chlorine, max. 0.6 mg/l combined chlorine, pH 6.9 to 7.7, water hardness 10 to 30 °dH, max. salt content 7 g/l)

Designation

Designation example

Position																															
1	2	3	4	5	6	7	8	9	10	11	12	13	14	15	16	17	18	19	20	21	22	23	24	25	26	27	28	29	30	31	32
E	T	P	L	0	8	0	-	0	8	0	-	2	0	0		G	C	X	I	1	0	D	3	0	1	8	5	2			B
See name plate and data sheet																								See data sheet							

Designation key

Position	Code	Description
1-4	Pump type	
	ETPL	Etaprime with bearing bracket
5-16	Size, e.g.	
	080	Nominal suction nozzle diameter [mm]
	080	Nominal discharge nozzle diameter [mm]
	200	Nominal impeller diameter [mm]
17	Pump casing material	
	G	Cast iron EN-GJL-250 / A48CL35
	C	Stainless steel 1.4408 / A743CF8M
18	Impeller material	
	G	Cast iron EN-GJL-250
	C	Stainless steel 1.4408
19	Design	
	.. ²⁾	Standard
	X	Non-standard (BT3D, BT3)
20	Shaft seal type	
	I	Single mechanical seal, internal circulation (conical seal chamber only)
	D	Double mechanical seal in back-to-back arrangement
	T	Double mechanical seal in tandem arrangement with internal circulation
21-22	Seal code, single mechanical seal	
	01	Q1Q1VGG
	08	AQ1VGG ³⁾
	09	U3U3VGG
	10	Q1Q1X4GG
	11	BQ1EGG
23	Scope of supply	
	A	Pump only (Fig. 0 bare-shaft pump)
	B	Pump, baseplate
	C	Pump, baseplate, coupling, coupling guard
	D	Pump, baseplate, coupling, coupling guard, motor
24	Shaft unit	
	1	Shaft unit 17
	2	Shaft unit 25
	3	Shaft unit 35
25-28	Motor rating P _N [kW]	
	0011	1,10
	0075	7,50
	0185	18,50
29	Number of motor poles	
30-31	Explosion protection	
	ex	With explosion-proof motor
	.. ²⁾	Without explosion-proof motor
32	Product generation	
	B	Etaprime Global Pump

2) Blank
3) BQVGG for shaft unit 17

Materials

A1 = default material variant
A2 = optional material variant

Part No.	Description	Material	Material variant		
			G	GC	C
102	Volute casing	Grey cast iron EN-GJL-250	A1	A1	-
		Stainless steel 1.4408	-	-	A1
161	Casing cover	Grey cast iron EN-GJL-250	A1	A1	-
		Stainless steel 1.4408	-	-	A1
210	Shaft for shaft units 25 and 35	Tempered steel C45+N	A1	A1	-
		Duplex stainless steel 1.4462	A2	A2	A1
	Shaft for shaft unit 17	Stainless steel 1.4571	A1	A1	A1
230	Impeller	Grey cast iron EN-GJL-250	A1	-	-
		Stainless steel 1.4408	-	A1	A1
330	Bearing bracket for shaft units 25 and 35	Grey cast iron EN-GJL-250	A1	A1	A1
350	Bearing housing for shaft unit 17	Grey cast iron EN-GJL-250	A1	A1	-
		Stainless steel 1.4408	-	-	A1
412	O-ring	EPDM 80 peroxide ⁴⁾	A1	A1	A1
523	Shaft sleeve (not for shaft unit 17)	Stainless steel 1.4571	A1	A1	A1

Product benefits

- Maintenance-free mechanical seal ensures operating reliability
- Easy to dismantle due to back pull-out design; no need to remove the pump casing from the piping
- Good suction performance, self-priming up to 9 m suction lift, also suitable for applications with relatively poor inlet conditions (i.e. low or negative inlet pressure) and for handling fluids with entrained gas.
- Optimised hydraulic components for high efficiency help reduce energy consumption

Certifications

Overview

Label	Effective in:	Comment
	All countries	Certified quality management to ISO 9001

4) FKM 80 on request

Overview of product features / selection tables
Overview of fluids handled

Table of fluids handled and associated material combinations
X = recommended variant

Fluid handled	Temperature	Materials			Shaft seal						Comments	
		Casing/impeller			Mechanical seal							
		Grey cast iron/ grey cast iron	Grey cast iron/ Cr-Ni-Mo cast steel	CrNiMo cast steel/ CrNiMo cast steel	Q1Q1VGG	AO1VGG ⁵⁾ BQVGG ⁶⁾	U3U3VGG	Q1Q1X4GG	BQ1EGG ⁵⁾	Q12Q1M1GG		
[°C]	G	GC	C	01	08	09	10	11	70			
Water												
Industrial waste water	-	-	-	-	-	-	-	-	-	-	-	Analysis of fluid handled required
Ammonia water (ammonia solution), percentage ≤ 10 %	≤ 40	X	-	-	-	-	-	-	X	-	-	Tandem seal Q1Q1EGG required. Quench liquid: use suitable water.
Brackish water	≤ 25	-	-	X	-	-	-	X	-	-	-	-
Fire-fighting water ⁷⁾	≤ 60	-	X	-	-	-	-	X	-	-	-	-
Condensate ⁵⁾	≤ 90	X	-	-	-	-	-	-	X	-	-	-
Condensate, not conditioned	≤ 90	-	-	X	-	-	-	-	X	-	-	-
Cooling water (without antifreeze) ⁷⁾	≤ 60	X	-	X ⁸⁾	-	-	-	X	-	-	-	-
Cooling water pH ≥ 7.5 (with antifreeze) ⁷⁾⁹⁾	≥ -30 to ≤ 90	X	-	X	-	-	-	-	X	-	-	-
Slightly contaminated water ⁷⁾	≤ 60	X	-	-	-	-	-	X	-	-	-	-
Seawater	≤ 25	-	-	X	-	-	-	X	-	-	-	-
Surface water ⁷⁾	≤ 40	X	-	-	-	X	-	-	-	-	-	Analysis of fluid handled required
Pure water ¹⁰⁾	≤ 60	X	-	-	-	-	-	-	X	-	-	-
Raw water ⁷⁾	≤ 60	X	-	-	-	-	-	X	-	-	-	-
Swimming pool water (fresh water) ⁷⁾	≤ 60	X	-	-	-	-	-	X	-	-	-	Also applies to requirements as per DIN 19643
Dam water ⁷⁾	≤ 60	X	-	-	-	-	-	X	-	-	-	If solids are contained, contact KSB.
Drinking water	≤ 60	-	-	X	-	-	-	-	-	-	-	-
Partly desalinated water ⁵⁾	≤ 90	X	-	-	-	-	-	-	X	-	-	-
Fully desalinated water	≤ 90	-	-	X	-	-	-	-	X	-	-	Requirements for ultra-pure water cannot be met.
Fully desalinated water as boiler feed water ⁵⁾	≤ 90	X	-	-	-	-	-	-	X	-	-	-
Refrigerants, cooling brines												
Cooling brine; inorganic, pH > 7.5, inhibited	≥ -30 to ≤ 25	X	-	-	-	-	-	-	X	-	-	-
Water with antifreeze, pH > 7.5 ⁷⁾⁹⁾	≥ -30 to ≤ 90	X	-	-	-	-	-	-	X	-	-	-
Oils/emulsions												
Drilling/grinding emulsion	≤ 60	X	-	-	-	-	X	-	-	-	-	-
Oil/water emulsion	≤ 60	X	-	-	-	-	X	-	-	-	-	-
Cleaning agent												

5) Treatment to VdTÜV 1466; additional requirement: O₂ ≤ 0.02 mg/l

6) Only applies to shaft unit 17.

7) General criteria for results of water analysis: pH ≥ 7; chloride content (Cl) ≤ 250 mg/kg. Chlorine (Cl₂) ≤ 0.6 mg/kg.

8) For open circuit

9) Antifreeze on ethylene glycol basis with inhibitors. Content: 20 % to 50 % (e.g. Antifrogen N), p ≤ 10 bar

10) No ultra-pure water! Conductivity at 25 °C: ≤ 800 µS/cm

Fluid handled	Temperature	Materials			Shaft seal						Comments
		Casing/impeller			Mechanical seal						
		Grey cast iron/ grey cast iron	Grey cast iron/ Cr-Ni-Mo cast steel	CrNiMo cast steel/ CrNiMo cast steel	Q1Q1VGG	AQ1VGG ⁵⁾ BQVGG ⁶⁾	U3U3VGG	Q1Q1X4GG	BQ1EGG ⁵⁾	Q12Q1M1GG	
[°C]	G	GC	C	01	08	09	10	11	70		
Lyes for bottle rinsers ¹¹⁾	≤ 90	X	-	-	-	-	-	X	-	-	EPDM only if oil-free
Acids											
Acetic acid, percentage ≤ 10 %	≤ 60	-	-	X	-	-	-	-	X	-	-
Alum, potassium aluminium sulphate up to 3 %	≤ 80	-	-	X	X	-	-	-	-	-	-

Overview of type series

Available sizes and designs

Size	Shaft unit	Etaprime L		Etaprime B	
		G	GC, C	G	GC, C
032-032-100	17	I/T	-	I/T	-
032-032-120	17	I/T	I/T	I/T	I/T
040-040-110	17	I/T	I/T	I/T	I/T
040-040-140	25	I/D/T	I/D/T	I/D/T	I/D/T
050-050-130	25	I/D/T	I/D/T	I/D/T	I/D/T
050-050-160	25	I/D/T	I/D/T	I/D/T	I/D/T
065-065-150	25	I/D/T	I/D/T	I/D/T	I/D/T
065-065-180	35	I/D/T	I/D/T	I/D/T	I/D/T
080-080-170	35	I/D/T	I/D/T	I/D/T	I/D/T
080-080-190	35	I/D/T	-	I/D/T	-
080-080-200	35	I/D/T	I/D/T	I/D/T	I/D/T
100-100-240.1	35	I/D/T	-	I/D/T	-
100-100-240	35	I/D/T	-	-	-
125-125-260	35	I/D/T	-	-	-

- I: Single mechanical seal (standard design)
- D: Available with double mechanical seal in back-to-back arrangement
- T: Available with double mechanical seal in tandem arrangement

Bearings

Bearings used

Standard bearing assembly

Version	Bearing bracket	Rolling element bearings	
		Pump end	Drive end
Standard bearing assembly (grease lubrication)	WE 17	3203 C3	6203 2RS
	WE 25	6305 2Z C3	6305 2Z C3
	WE 35	6307 2Z C3	6307 2Z C3
Standard bearing assembly (oil lubrication)	WE 17	-	-
	WE 25	6305 C3	6305 C3
	WE 35	6307 C3	6307 C3

Selection Information

Priming time

For a 1-metre horizontal length of the suction line and DN suction line = DN pump, the priming times are as follows.

11) With 2 % sodium hydroxide

When handling gaseous fluids, fluids which tend to froth or water with a temperature $T > 60\text{ °C}$, the pump will not be self-priming. In such cases, a check valve must be installed in the suction line.

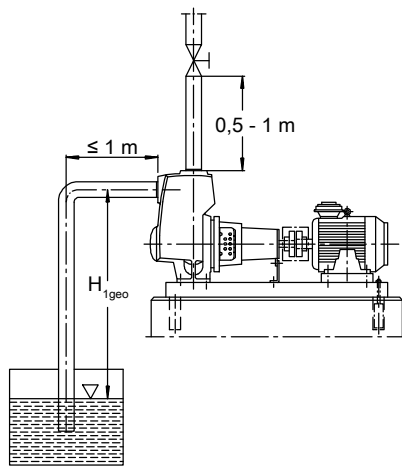

Fig. 1: Distances of suction line and discharge line

Priming time in [seconds] at a static suction lift H_{1geo} of ... m, depending on the speed, 50 Hz

Size	Shaft unit	n = 2900 rpm						n = 1450 rpm							
		2 m	4 m	5 m	6 m	7 m	8 m	1 m	2 m	3 m	4 m	5 m	6 m	7 m	8 m
025-025-100	17	40	145	415	-	-	-	130	-	-	-	-	-	-	-
032-032-120	17	30	90	135	190	255	360	100	210	-	-	-	-	-	-
040-040-110	17	60	100	215	420	-	-	120	-	-	-	-	-	-	-
040-040-140	25	30	70	125	220	355	600	130	-	-	-	-	-	-	-
050-050-130	25	50	120	195	260	345	440	210	410	-	-	-	-	-	-
050-050-160	25	30	70	105	170	265	430	210	430	-	-	-	-	-	-
065-065-150	25	60	120	165	260	375	570	190	350	540	-	-	-	-	-
065-065-180	35	30	50	75	100	145	200	90	140	220	370	-	-	-	-
080-080-170	35	50	100	135	180	225	310	110	180	280	480	-	-	-	-
080-080-190	35	40	70	105	160	185	240	100	110	200	310	-	-	-	-
080-080-200	35	30	50	75	105	155	200	70	110	190	270	320	420	-	-
100-100-240.1	35	30	70	95	120	150	190	130	150	220	300	440	-	-	-
100-100-240	35	35	70	85	110	160	-	110	160	270	480	-	-	-	-
125-125-260	35	35	80	105	130	160	190	60	70	110	160	200	330	430	610

Priming time in [seconds] at a static suction lift H_{1geo} of ... m, depending on the speed, 60 Hz

Size	Shaft unit	n = 3500 rpm						n = 1750 rpm							
		2 m	4 m	5 m	6 m	7 m	8 m	1 m	2 m	3 m	4 m	5 m	6 m	7 m	8 m
025-025-100	17	30	85	135	-	-	-	70	170	-	-	-	-	-	-
032-032-120	17	20	60	105	140	175	250	80	150	260	-	-	-	-	-
040-040-110	17	30	85	125	200	265	470	90	180	-	-	-	-	-	-
040-040-140	25	25	50	85	120	145	230	80	150	200	-	-	-	-	-
050-050-130	25	30	90	140	190	245	300	130	240	380	-	-	-	-	-
050-050-160	25	25	55	75	150	215	280	130	260	480	-	-	-	-	-
065-065-150	25	40	80	125	170	225	370	140	260	350	430	-	-	-	-
065-065-180	35	20	40	65	90	105	150	80	110	170	220	330	-	-	-
080-080-170	35	30	80	105	130	165	220	90	130	200	320	480	-	-	-
080-080-190	35	30	55	75	100	125	160	80	100	130	160	210	390	-	-
080-080-200	35	25	40	55	80	125	160	60	100	160	230	280	350	-	-
100-100-240.1	35	25	60	85	115	145	180	90	110	140	210	260	400	-	-
100-100-240	35	25	70	85	100	155	360	80	100	140	200	300	-	-	-
125-125-260	35	-	-	-	-	-	-	50	60	80	115	170	220	300	400

12) The sum of inlet pressure and shut-off head must not exceed the values indicated.

13) The casing components are checked for leakage by means of internal pressure tests with water.

Pressure limits

Size	Max. discharge-side operating pressure ¹²⁾	Test pressure ¹³⁾
	[bar]	[bar]
All	10,0	15,0

Selection Charts

Etaprime L / Etaprime B, n = 2900 rpm (* also available in stainless steel material variant)

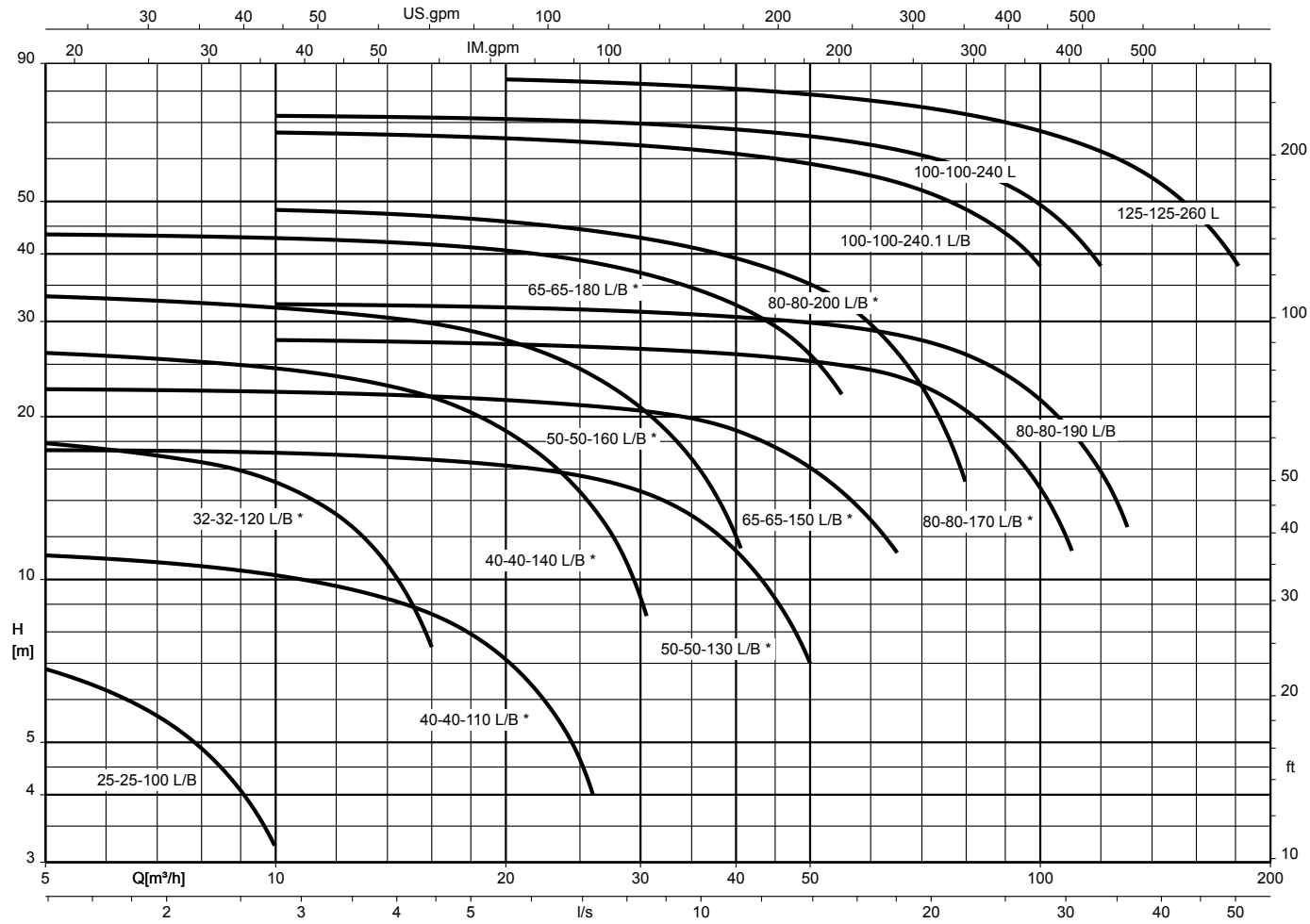

Etaprime L / Etaprime B, n = 1450 rpm (* also available in stainless steel material variant)

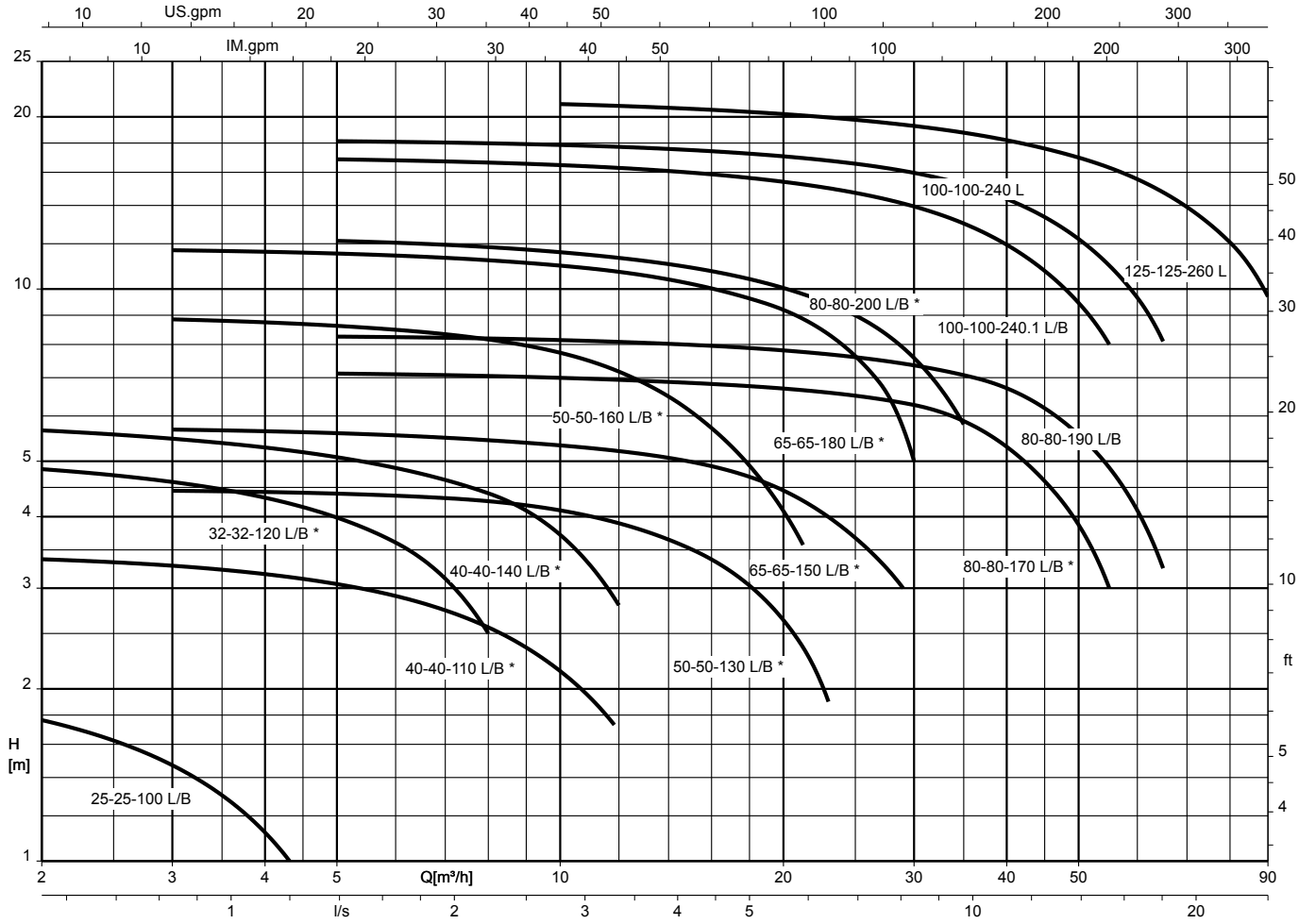

Etaprime L / Etaprime B, n = 3500 rpm (* also available in stainless steel material variant)

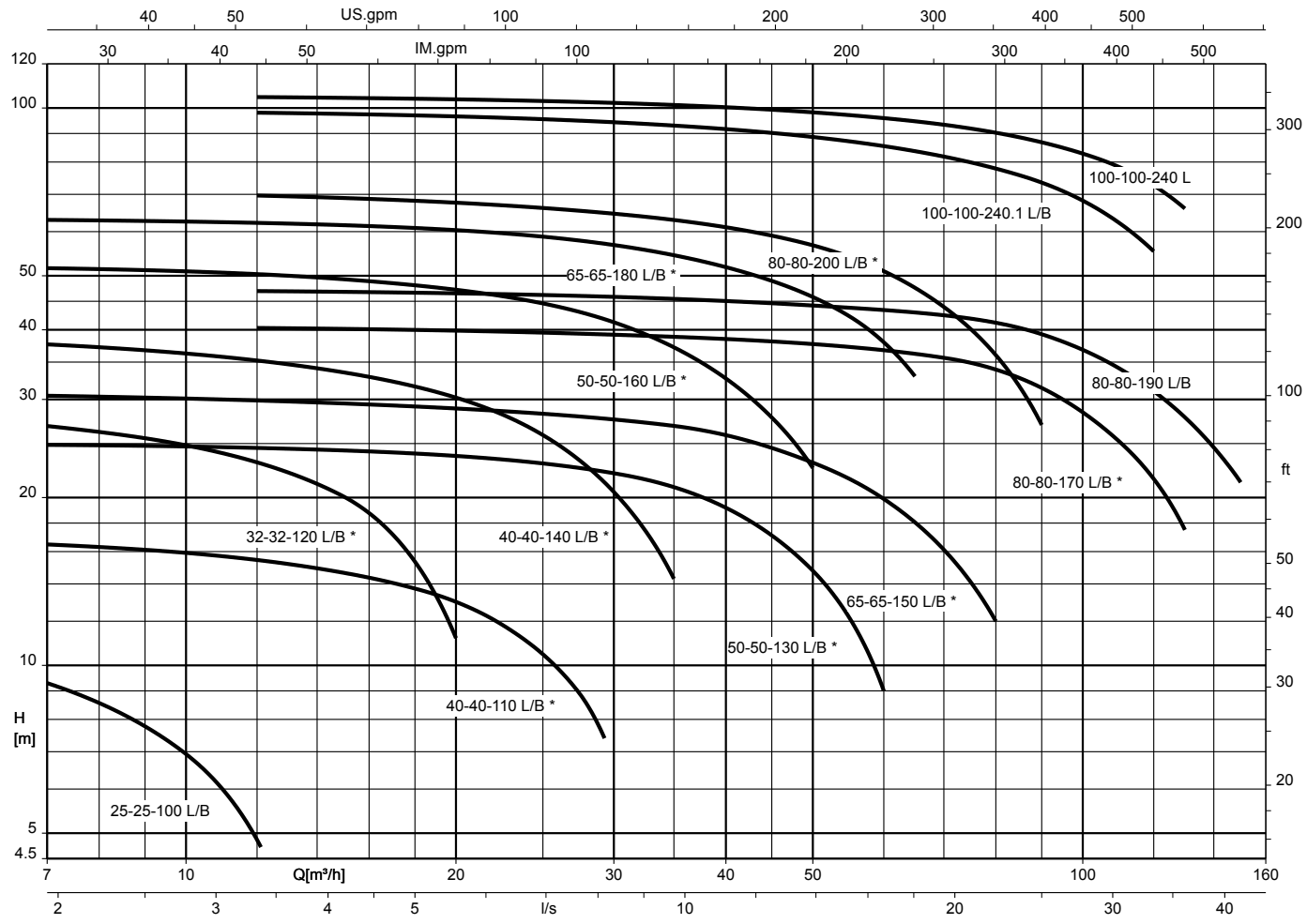

Etaprime L / Etaprime B, n = 1750 rpm (* also available in stainless steel material variant)

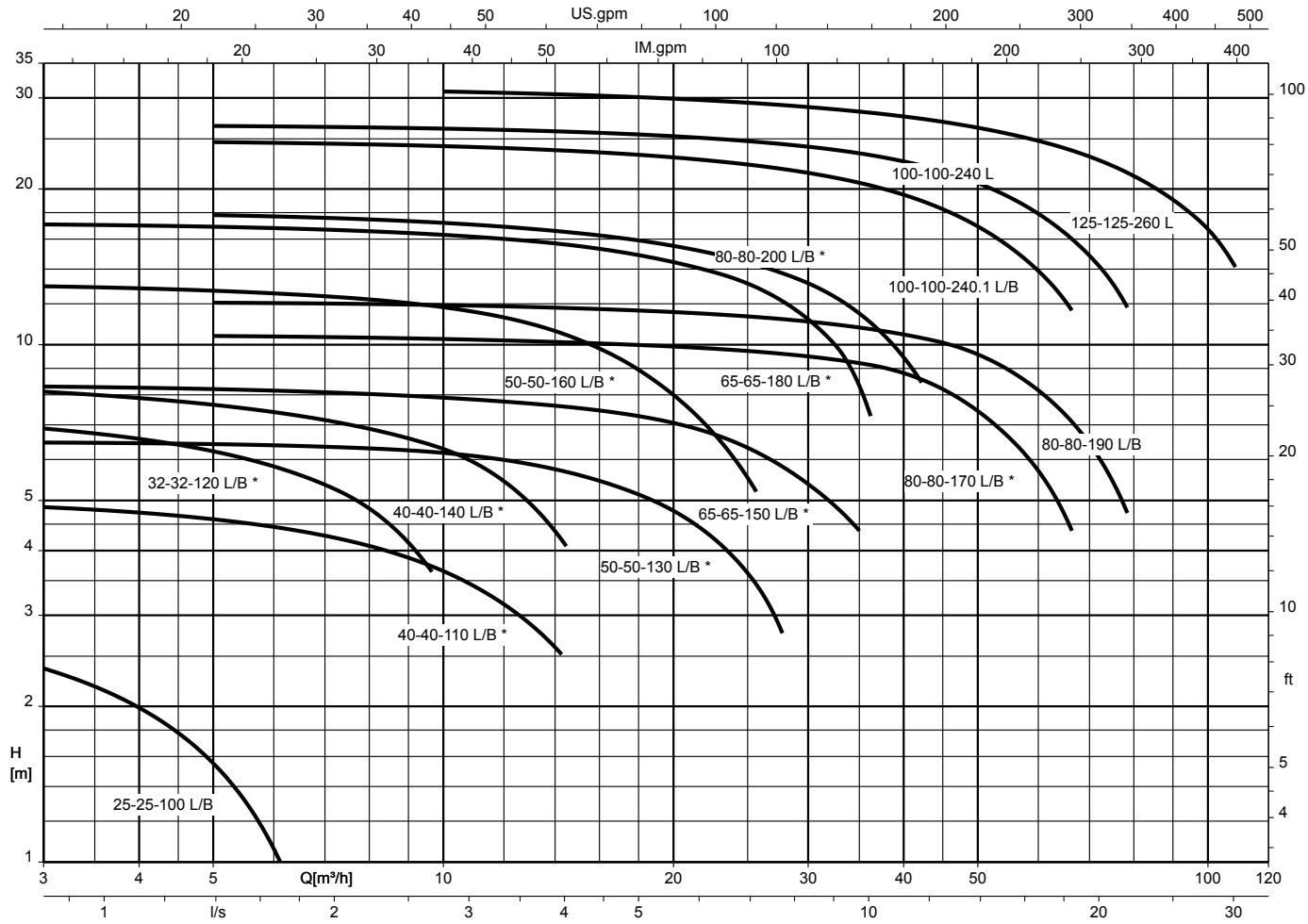

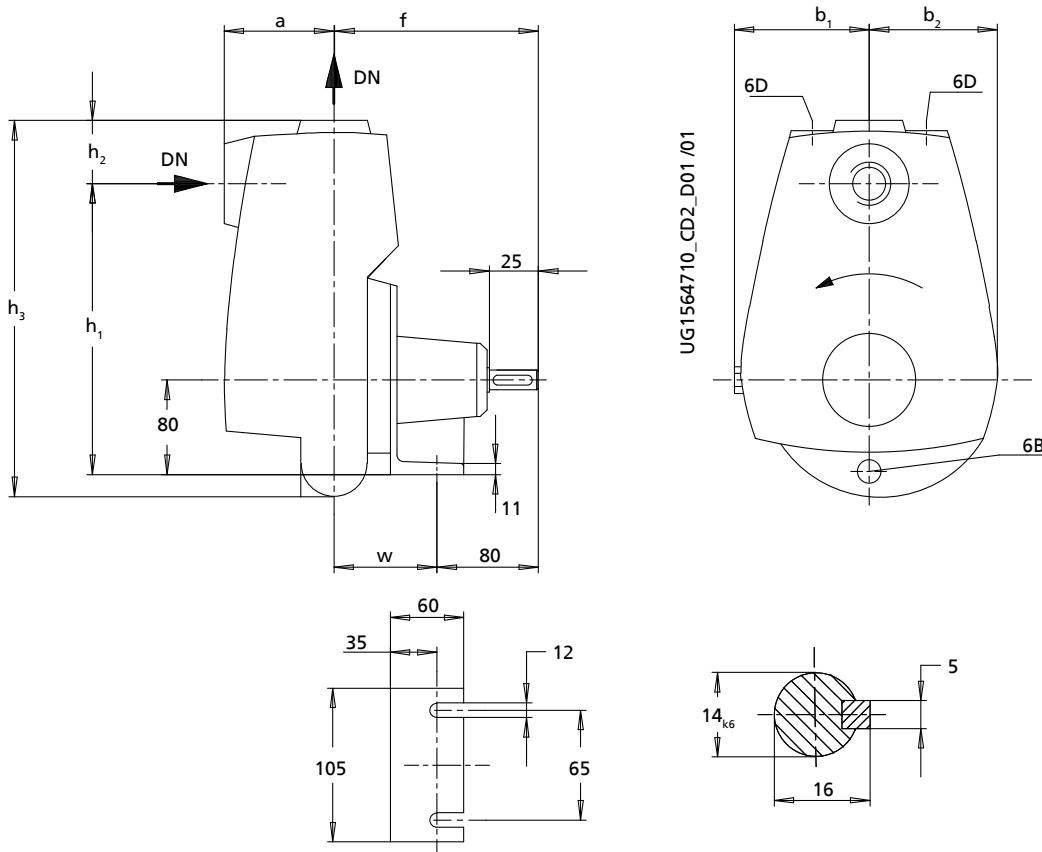
Dimensions and connections
Etaprime L 025-025-100 to 040-040-110 (shaft unit 17) – pump

Fig. 2: Dimensions of sizes 025-025-100 to 040-040-110 (shaft unit 17) – pump

6B	Fluid drain	6D	Fluid priming and venting
----	-------------	----	---------------------------

Connections

Etaprime L	6 B¹⁴⁾	6D¹⁴⁾
025-025-100	G 1/8	G 3/8
032-032-120	G 1/8	G 3/8
040-040-110	G 1/8	G 3/8

Pump dimensions [mm]

Etaprime L	Connection		Pump							
	Standard	Optional	a	b₁	b₂	f	h₁	h₂	h₃	w
	DN¹⁵⁾	DN¹⁶⁾								
020-025-100	Rp 1	NPT 1	70	104	95	169	220	38	265	89
032-032-120	Rp 1 1/4	NPT 1 1/4	95	118	95	165	229	46	286	85
040-040-110	Rp 1 1/2	NPT 1 1/2	105	118	110	171	235	55	312	91

14) G = ISO 228/1

15) Standard connection to ISO 7/1

16) Optional connection to ASME B1.20.1

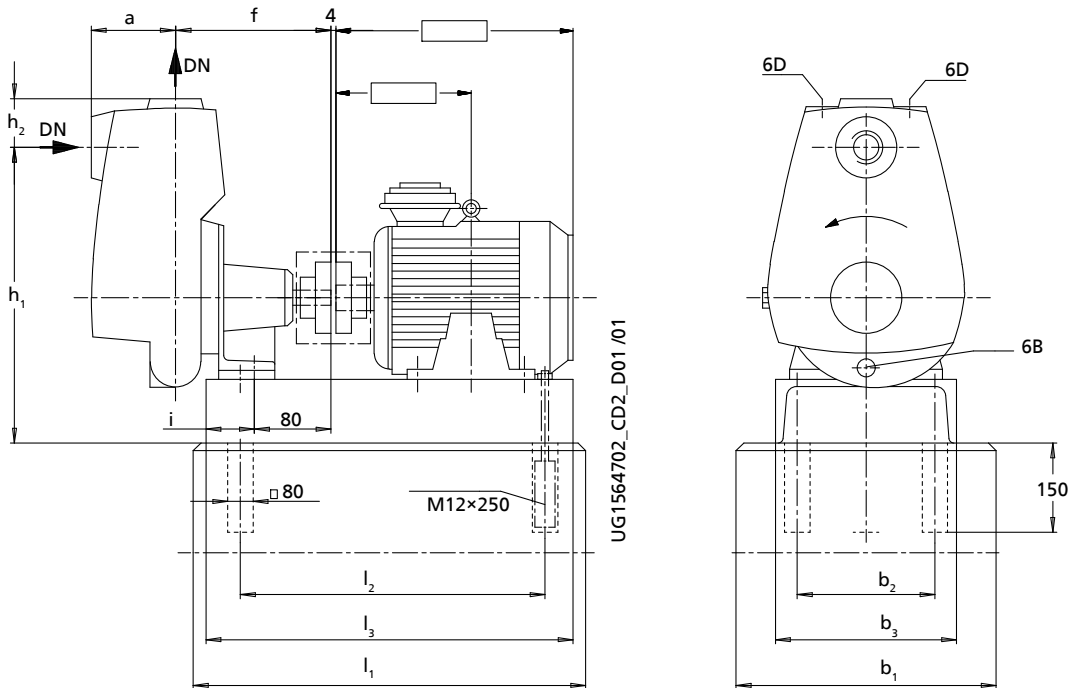
Etaprime L 025-025-100 to 040-040-110 (shaft unit 17) – pump set

Fig. 3: Dimensions of sizes 025-025-100 to 040-040-110 (shaft unit 17) – pump set

6B	Fluid drain	6D	Fluid priming and venting
----	-------------	----	---------------------------

Pump set dimensions [mm]

Etaprime L	n				P _N	IEC motor	Connection		Pump set										
	1450	1750	2900	3500			Standard	Optional	a	f	h ₁	h ₂	b ₁	b ₂	b ₃	i	l ₁	l ₂	l ₃
025-025-100	X	X	-	-	0,37	71	Rp 1	NPT 1	70	169	295	38	350	160	200	41,5	570	360	420
025-025-100	X	X	-	-	0,55	80M	Rp 1	NPT 1	70	169	295	38	350	160	200	41,5	570	360	420
025-025-100	-	-	X	-	0,55	71	Rp 1	NPT 1	70	169	295	38	350	160	200	41,5	570	360	420
025-025-100	-	-	-	X	0,75	80M	Rp 1	NPT 1	70	169	295	38	350	160	200	41,5	570	360	420
025-025-100	-	-	-	X	1,10	80M	Rp 1	NPT 1	70	169	295	38	350	160	200	41,5	570	360	420
032-032-120	X	X	-	-	0,37	71	R 1 1/4	NPT 1 1/4	95	165	304	46	350	160	200	41,5	570	360	420
032-032-120	X	X	-	-	0,55	80M	R 1 1/4	NPT 1 1/4	95	165	304	46	350	160	200	41,5	570	360	420
032-032-120	-	-	X	-	1,10	80M	R 1 1/4	NPT 1 1/4	95	165	304	46	350	160	200	41,5	570	360	420
032-032-120	-	-	-	X	2,20	90L	R 1 1/4	NPT 1 1/4	95	165	314	46	350	160	200	41,5	570	360	420
040-040-110	X	X	-	-	0,37	71	Rp 1 1/2	NPT 1 1/2	105	171	310	55	350	160	200	41,5	570	360	420
040-040-110	X	X	-	-	0,55	80M	Rp 1 1/2	NPT 1 1/2	105	171	310	55	350	160	200	41,5	570	360	420
040-040-110	-	-	X	-	1,10	80M	Rp 1 1/2	NPT 1 1/2	105	171	310	55	350	160	200	41,5	570	360	420
040-040-110	-	-	-	X	1,50	90S	Rp 1 1/2	NPT 1 1/2	105	171	320	55	350	160	200	41,5	570	360	420

17) Standard connection to ISO 7/1

18) Optional connection to ASME B1.20.1

Etaprime L 040-040-140 to 125-125-260 (shaft units 25/35) – pump

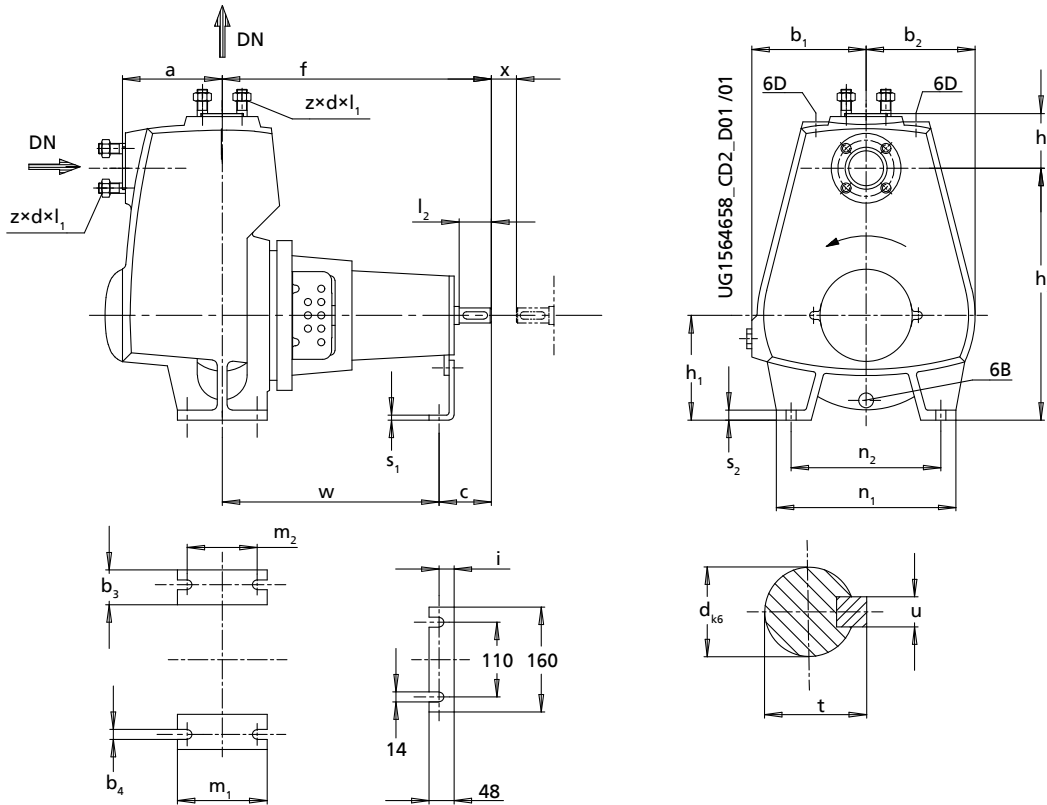

Fig. 4: Dimensions of sizes 040-040-140 to 125-125-260 (shaft units 25/35) – pump

6B	Fluid drain	6D	Fluid priming and venting
----	-------------	----	---------------------------

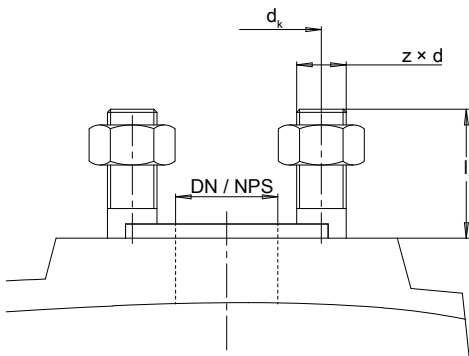

Fig. 5: Flange dimensions

Connections

Etaprime L	6B¹⁹⁾	6D¹⁹⁾
040-040-140	G 3/8	G 3/8
050-050-130	G 3/8	G 3/8
050-050-160	G 3/8	G 3/8
065-065-150	G 3/8	G 3/8
065-065-180	G 3/8	G 3/8
080-080-170	G 1/2	G 1/2
080-080-190	G 1/2	G 1/2
080-080-200	G 1/2	G 1/2
100-100-240.1	G 1/2	G 1/2
100-100-240	G 1/2	G 1/2
125-125-260	G 1/2	G 1/2

Flange dimensions [mm]

Flanged connection	DN	d_k	z	d	l₁
Standard:	40	110	4	M16	40
▪ Drilled to EN 1092-1 (material variant C)	50	125	4	M16	40
▪ Drilled to EN 1092-2 (material variant G / GC)	65	145	4	M16	40
	80	160	8	M16	45
	100	180	8	M16	45
	125	210	8	M16	45
Optional:	NPS 1 1/2	98,6	4	UNC 1/2-13	40
▪ Drilled to ASME B16.1 (material variant G / GC)	NPS 2	120,7	4	UNC 5/8-11	40
▪ Drilled to ASME B16.5 (material variant C)	NPS 2 1/2	139,7	4	UNC 5/8-11	40
	NPS 3	152,4	4	UNC 5/8-11	40
	NPS 4	190,5	8	UNC 5/8-11	45
	NPS 5	215,9	8	UNC 3/4-10	45

Pump dimensions [mm]

Etaprime L	Pump																						
	DN	a	b₁	b₂	b₃	b₄	c	d_{k6}	f	h₁	h₂	h₃	i	l₂	m₁	m₂	n₁	n₂	s₁	s₂	t	u	w
040-040-140	40	115	115	128	57	16	100	24	370	112	284	73	23	50	100	70	220	160	4	13	27	8	270
050-050-130	50	130	138	128	55	16	100	24	370	132	317	78	23	50	100	70	250	190	4	17	27	8	270
050-050-160	50	130	145	126	55	16	100	24	370	132	327	75	23	50	100	70	250	190	4	17	27	8	270
065-065-150	65	140	155	149	55	16	100	24	370	160	370	85	25	50	125	95	270	212	6	20	27	8	270
065-065-180	65	140	158	138	55	16	130	32	490	160	376	89	23	80	125	95	270	212	4	18	35	10	360
080-080-170	80	156	173	168	65	18	130	32	490	160	380	104	23	80	140	106	310	240	4	18	35	10	360
080-080-190	80	170	188	181	65	20	130	32	490	180	420	107	24	80	160	120	345	280	6	22	35	10	360
080-080-200	80	154	172	152	65	20	130	32	490	160	378	107	24	80	140	100	285	220	4	22	35	10	360
100-100-240.1	100	182	203	178	68	20	130	32	478	200	457	127	24	80	140	100	330	260	6	18	35	10	348
100-100-240	100	182	203	178	68	20	130	32	478	200	457	127	24	80	140	100	330	260	6	18	35	10	348
125-125-260	125	204	227	197	70	20	130	32	478	200	486	142	24	80	140	100	340	270	6	18	35	10	348

19) G = ISO 228/1

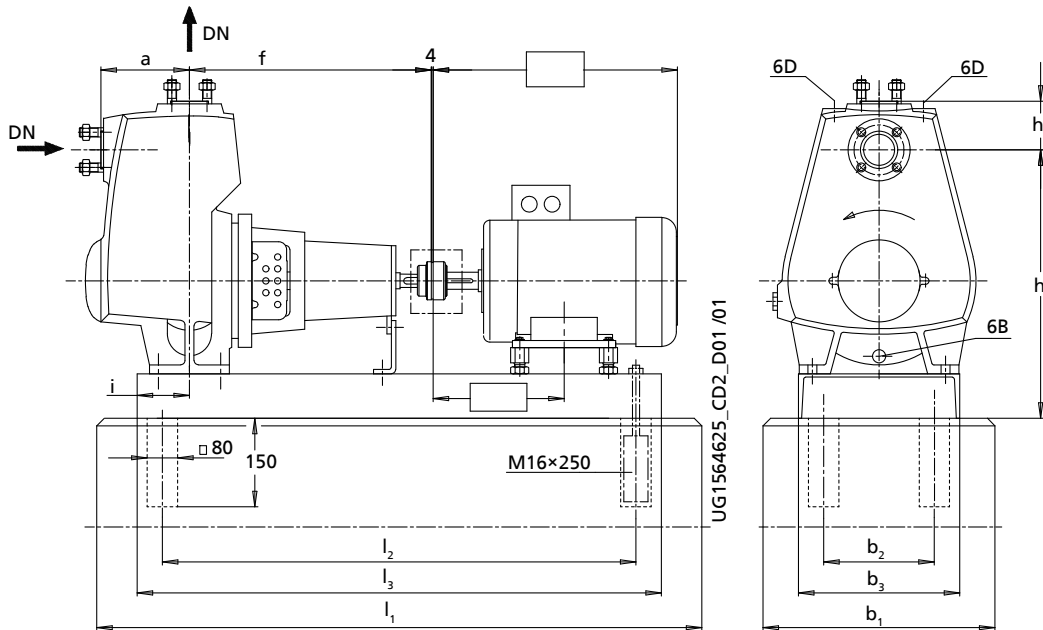
Etaprime L 040-040-140 to 125-125-260 (shaft units 25/35) – pump set with coupling

Fig. 6: Dimensions of sizes 040-040-140 to 125-125-260 (shaft units 25/35) – pump set with coupling

6B	Fluid drain	6D	Fluid priming and venting
----	-------------	----	---------------------------

Pump set dimensions [mm]

Etaprime L	n				P _N	Motor	Pump set											
	1450	1750	2900	3500			DN	a	f	h ₁	h ₂	b ₁	b ₂	b ₃	i	l ₁	l ₂	l ₃
	[rpm]																	
040-040-140	X	X	-	-	1,50	90L	40	115	370	384	73	450	240	300	100	950	740	800
040-040-140	-	-	X	-	2,20	90L	40	115	370	384	73	450	240	300	100	950	740	800
040-040-140	-	-	X	-	3,00	100L	40	115	370	384	73	450	240	300	100	950	740	800
040-040-140	-	-	-	X	4,00	112M	40	115	370	384	73	450	240	300	100	1050	840	900
040-040-140	-	-	-	X	5,50	132S	40	115	370	404	73	450	240	300	100	1050	840	900
050-050-130	X	X	-	-	1,50	90L	50	130	370	417	78	450	240	300	100	950	740	800
050-050-130	-	-	X	-	2,20	90L	50	130	370	417	78	450	240	300	100	950	740	800
050-050-130	-	-	X	-	3,00	100L	50	130	370	417	78	450	240	300	100	950	740	800
050-050-130	-	-	-	X	4,00	112M	50	130	370	417	78	450	240	300	100	1050	840	900
050-050-160	X	X	-	-	1,50	90L	50	130	370	427	75	450	240	300	112	950	740	800
050-050-160	-	-	X	-	4,00	112M	50	130	370	427	75	450	240	300	112	1050	840	900
050-050-160	-	-	X	X	5,50	132S	50	130	370	427	75	450	240	300	112	1150	940	1000
050-050-160	-	-	-	X	7,50	132S	50	130	370	427	75	450	240	300	112	1150	940	1000
065-065-150	X	X	-	-	1,50	90L	65	140	370	470	85	450	240	300	112	950	740	800
065-065-150	-	-	X	-	4,00	112M	65	140	370	470	85	450	240	300	112	1050	840	900
065-065-150	-	-	X	X	5,50	132S	65	140	370	470	85	450	240	300	112	1150	940	1000
065-065-150	-	-	-	X	7,50	132S	65	140	370	470	85	450	240	300	112	1150	940	1000
065-065-180	X	X	-	-	2,20	100L	65	140	490	476	89	500	280	350	112	1270	1060	1120
065-065-180	-	-	X	-	5,50	132S	65	140	490	476	89	500	280	350	112	1270	1060	1120
065-065-180	-	-	X	-	7,50	132S	65	140	490	476	89	500	280	350	112	1270	1060	1120
065-065-180	-	-	-	X	11,00	160M	65	140	490	476	89	500	280	350	112	1270	1060	1120
080-080-170	X	X	-	-	2,20	100L	80	156	490	480	104	500	280	350	120	1270	1060	1120
080-080-170	-	-	X	-	7,50	132S	80	156	490	480	104	500	280	350	120	1270	1060	1120
080-080-170	-	-	-	X	11,00	160M	80	156	490	480	104	500	280	350	120	1270	1060	1120
080-080-170	-	-	-	X	15,00	160M	80	156	490	480	104	500	280	350	120	1270	1060	1120
080-080-190	X	X	-	-	2,20	100L	80	170	490	520	107	500	280	350	130	1270	1060	1120
080-080-190	X	X	-	-	3,00	100L	80	170	490	520	107	500	280	350	130	1270	1060	1120
080-080-190	-	-	X	-	11,00	160M	80	170	490	520	107	500	280	350	130	1400	1190	1250
080-080-190	-	-	-	X	15,00	160M	80	170	490	520	107	500	280	350	130	1400	1190	1250
080-080-190	-	-	-	X	18,50	160L	80	170	490	520	107	500	280	350	130	1400	1190	1250
080-080-200	X	X	-	-	2,20	100L	80	154	490	478	107	500	280	350	120	1270	1060	1120

Etaprime L	n				P _N	Motor	Pump set											
	1450	1750	2900	3500			DN	a	f	h ₁	h ₂	b ₁	b ₂	b ₃	i	l ₁	l ₂	l ₃
	[rpm]				[kW]													
080-080-200	-	-	X	-	11,00	160M	80	154	490	478	107	500	280	350	120	1400	1190	1250
080-080-200	-	-	-	X	15,00	160M	80	154	490	478	107	500	280	350	120	1400	1190	1250
080-080-200	-	-	-	X	18,50	160L	80	154	490	478	107	500	280	350	120	1400	1190	1250
100-100-240.1	X	X	-	-	2,20	100L	100	182	478	557	127	500	280	350	120	1270	1060	1120
100-100-240.1	X	X	-	-	3,00	100L	100	182	478	557	127	500	280	350	120	1270	1060	1120
100-100-240.1	X	X	-	-	4,00	112M	100	182	478	557	127	500	280	350	120	1270	1060	1120
100-100-240.1	-	-	X	-	15,00	160M	100	182	478	557	127	500	280	350	120	1270	1060	1120
100-100-240.1	-	-	X	-	18,50	160L	100	182	478	557	127	500	280	350	120	1400	1190	1250
100-100-240.1	-	-	-	X	22,00	180M	100	182	478	567	127	550	320	400	120	1400	1190	1250
100-100-240.1	-	-	-	X	30,00	200L	100	182	478	567	127	550	320	400	120	1400	1190	1250
100-100-240	X	X	-	-	3,00	100L	100	182	478	557	127	500	280	350	120	1270	1060	1120
100-100-240	X	X	-	-	4,00	112M	100	182	478	557	127	500	280	350	120	1270	1060	1120
100-100-240	X	X	-	-	5,50	132S	100	182	478	557	127	500	280	350	120	1270	1060	1120
100-100-240	-	-	X	-	22,00	180M	100	182	478	567	127	550	320	400	120	1400	1190	1250
100-100-240	-	-	X	-	30,00	200L	100	182	478	567	127	550	320	400	120	1400	1190	1250
100-100-240	-	-	-	X	37,00	200L	100	182	478	567	127	550	320	400	120	1400	1190	1250
125-125-260	X	X	-	-	5,50	132S	125	204	478	586	142	500	280	350	120	1270	1060	1120
125-125-260	X	X	-	-	7,50	132M	125	204	478	586	142	500	280	350	120	1270	1060	1120
125-125-260	X	X	-	-	11,00	160M	125	204	478	596	142	550	320	400	120	1400	1190	1250
125-125-260	-	-	X	-	30,00	200L	125	204	478	596	142	550	320	400	120	1400	1190	1250
125-125-260	-	-	X	-	37,00	200L	125	204	478	596	142	550	320	400	120	1400	1190	1250

Etaprime L 040-040-140 to 125-125-260 (shaft units 25/35) – pump set with spacer-type coupling

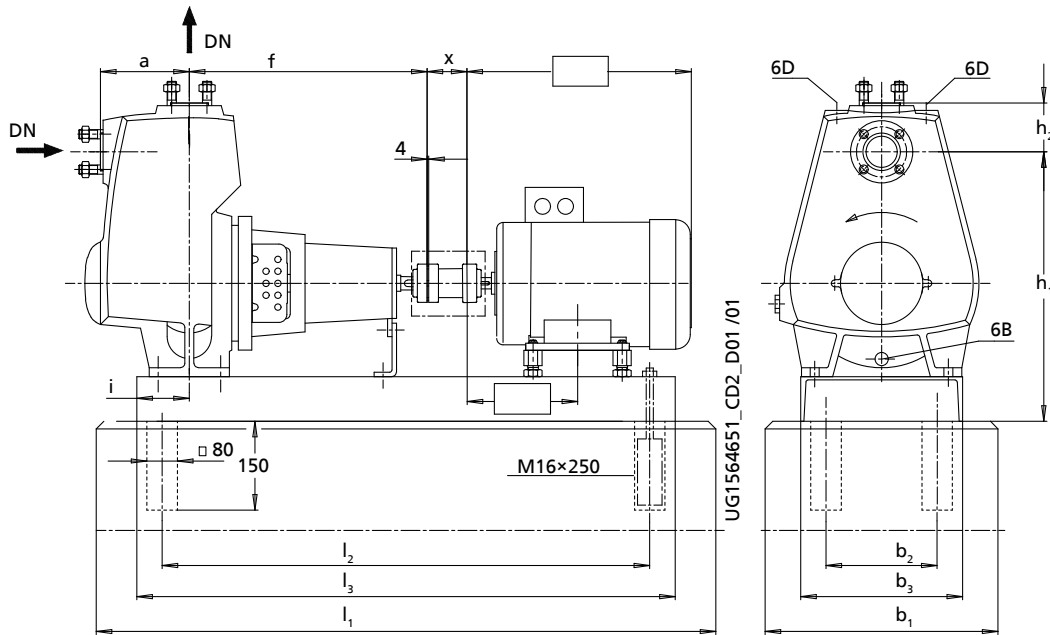

Fig. 7: Dimensions of sizes 040-040-140 to 125-125-260 (shaft units 25/35) – pump set with spacer-type coupling

6B	Fluid drain	6D	Fluid priming and venting
----	-------------	----	---------------------------

Pump set dimensions [mm]

Etaprime L	n				P _N [kW]	Motor	Pump set												
	1450	1750	2900	3500			DN	a	f	h ₁	h ₂	b ₁	b ₂	b ₃	i	l ₁	l ₂	l ₃	x
	[rpm]																		
040-040-140	X	X	-	-	1,50	90L	40	115	370	384	73	450	240	300	100	1050	840	900	100
040-040-140	-	-	X	-	2,20	90L	40	115	370	384	73	450	240	300	100	1050	840	900	100
040-040-140	-	-	X	-	3,00	100L	40	115	370	384	73	450	240	300	100	1050	840	900	100
040-040-140	-	-	-	X	4,00	112M	40	115	370	384	73	450	240	300	100	1150	940	1000	100
040-040-140	-	-	-	X	5,50	132S	40	115	370	404	73	450	240	300	100	1150	940	1000	100
050-050-130	X	X	-	-	1,50	90L	50	130	370	417	78	450	240	300	100	1050	840	900	100
050-050-130	-	-	X	-	2,20	90L	50	130	370	417	78	450	240	300	100	1050	840	900	100
050-050-130	-	-	X	-	3,00	100L	50	130	370	417	78	450	240	300	100	1050	840	900	100
050-050-130	-	-	-	X	4,00	112M	50	130	370	417	78	450	240	300	100	1150	940	1000	100
050-050-160	X	X	-	-	1,50	90L	50	130	370	427	75	450	240	300	112	1050	840	900	100
050-050-160	-	-	X	-	4,00	112M	50	130	370	427	75	450	240	300	112	1150	940	1000	100
050-050-160	-	-	X	X	5,50	132S	50	130	370	427	75	500	280	350	112	1270	1060	1120	100
050-050-160	-	-	-	X	7,50	132S	50	130	370	427	75	500	280	350	112	1270	1060	1120	100
065-065-150	X	X	-	-	1,50	90L	65	140	370	470	85	450	240	300	112	1050	840	900	100
065-065-150	-	-	X	-	4,00	112M	65	140	370	470	85	450	240	300	112	1150	940	1000	100
065-065-150	-	-	X	X	5,50	132S	65	140	370	470	85	500	280	350	112	1270	1060	1120	100
065-065-150	-	-	-	X	7,50	132S	65	140	370	470	85	500	280	350	112	1270	1060	1120	100
065-065-180	X	X	-	-	2,20	100L	65	140	490	476	89	500	280	350	112	1400	1190	1250	140
065-065-180	-	-	X	-	5,50	132S	65	140	490	476	89	500	280	350	112	1400	1190	1250	140
065-065-180	-	-	X	-	7,50	132S	65	140	490	476	89	500	280	350	112	1400	1190	1250	140
065-065-180	-	-	-	X	11,00	160M	65	140	490	476	89	500	280	350	112	1400	1190	1250	140
080-080-170	X	X	-	-	2,20	100L	80	156	490	480	104	500	280	350	120	1400	1190	1250	140
080-080-170	-	-	X	-	7,50	132S	80	156	490	480	104	500	280	350	120	1400	1190	1250	140
080-080-170	-	-	-	X	11,00	160M	80	156	490	480	104	500	280	350	120	1400	1190	1250	140
080-080-170	-	-	-	X	15,00	160M	80	156	490	480	104	500	280	350	120	1400	1190	1250	140
080-080-190	X	X	-	-	2,20	100L	80	170	490	520	107	550	280	350	120	1400	1190	1250	140
080-080-190	X	X	-	-	3,00	100L	80	170	490	520	107	550	280	350	120	1400	1190	1250	140
080-080-190	-	-	X	-	11,00	160M	80	170	490	530	107	550	320	400	130	1570	1360	1420	140
080-080-190	-	-	-	X	15,00	160M	80	170	490	530	107	550	320	400	130	1570	1360	1420	140
080-080-190	-	-	-	X	18,50	160L	80	170	490	530	107	550	320	400	130	1570	1360	1420	140
080-080-200	X	X	-	-	2,20	100L	80	154	490	478	107	500	280	350	120	1400	1190	1250	140

Etaprime L	n				P _N	Motor	Pump set												
	1450	1750	2900	3500			DN	a	f	h ₁	h ₂	b ₁	b ₂	b ₃	i	l ₁	l ₂	l ₃	x
	[rpm]				[kW]														
080-080-200	-	-	X	-	11,00	160M	80	154	490	488	107	550	320	400	120	1570	1360	1420	140
080-080-200	-	-	-	X	15,00	160M	80	154	490	488	107	550	320	400	120	1570	1360	1420	140
080-080-200	-	-	-	X	18,50	160L	80	154	490	488	107	550	320	400	120	1570	1360	1420	140
100-100-240.1	X	X	-	-	2,20	100L	100	182	478	557	127	500	280	350	120	1400	1190	1250	140
100-100-240.1	X	X	-	-	3,00	100L	100	182	478	557	127	500	280	350	120	1400	1190	1250	140
100-100-240.1	X	X	-	-	4,00	112M	100	182	478	557	127	500	280	350	120	1400	1190	1250	140
100-100-240.1	-	-	X	-	15,00	160M	100	182	478	557	127	500	280	350	120	1400	1190	1250	140
100-100-240.1	-	-	X	-	18,50	160L	100	182	478	567	127	550	320	400	120	1570	1360	1420	140
100-100-240.1	-	-	-	X	22,00	180M	100	182	478	567	127	550	320	400	120	1570	1360	1420	140
100-100-240.1	-	-	-	X	30,00	200L	100	182	478	567	127	550	320	400	120	1570	1360	1420	140
100-100-240	X	X	-	-	3,00	100L	100	182	478	557	127	500	280	350	120	1400	1190	1250	140
100-100-240	X	X	-	-	4,00	112M	100	182	478	557	127	500	280	350	120	1400	1190	1250	140
100-100-240	X	X	-	-	5,50	132S	100	182	478	557	127	500	280	350	120	1400	1190	1250	140
100-100-240	-	-	X	-	22,00	180M	100	182	478	567	127	550	320	400	120	1570	1360	1420	140
100-100-240	-	-	X	-	30,00	200L	100	182	478	567	127	550	320	400	120	1570	1360	1420	140
100-100-240	-	-	-	X	37,00	200L	100	182	478	567	127	550	320	400	120	1570	1360	1420	140
125-125-260	X	X	-	-	5,50	132S	125	204	478	596	142	550	320	400	120	1570	1360	1420	140
125-125-260	X	X	-	-	7,50	132M	125	204	478	596	142	550	320	400	120	1570	1360	1420	140
125-125-260	X	X	-	-	11,00	160M	125	204	478	596	142	550	320	400	120	1570	1360	1420	140
125-125-260	-	-	X	-	30,00	200L	125	204	478	596	142	550	320	400	120	1570	1360	1420	140
125-125-260	-	-	X	-	37,00	200L	125	204	478	596	142	550	320	400	120	1570	1360	1420	140

Flange designs

Threaded connections, shaft unit 17

Size	Shaft unit	Material variant			
		G/GC/C			
		Connection pipe thread to			
		ISO 7-1 PN10		ASME B1.20.1 PN10	
025-025-100	17	Rp 1	X	NPT 1	o
032-032-120	17	Rp 1 1/4	X	NPT 1 1/4	o
040-040-110	17	Rp 1 1/2	X	NPT 1 1/2	o

 Flanged connections²⁰⁾ shaft units 25, 35

Size	Shaft unit	Nominal size to		Material variant			
				G/GC		C	
				Flange dimensions to			
		EN 1092-2		EN 1092-1			
		EN 1092		ASME		Drilled to	
				EN 1092-2 PN16	ASME B16.1 CL125	EN 1092-1 PN16	ASME B16.5 CL150
040-040-110	25	DN 40	NPS 1 1/2	X	o	X	o
050-050-130	25	DN 50	NPS 2	X	o	X	o
050-050-160	25	DN 50	NPS 2	X	o	X	o
065-065-150	25	DN 65	NPS 2 1/2	X	o	X	o
065-065-180	35	DN 65	NPS 2 1/2	X	o	X	o
080-080-170	35	DN 80	NPS 3	X	o	X	o
080-080-190	35	DN 80	NPS 3	X	o	-	-
080-080-200	35	DN 80	NPS 3	X	o	X	o
100-100-240.1	35	DN 100	NPS 4	X	o	-	-
100-100-240	35	DN 100	NPS 4	X	o	-	-
125-125-260	35	DN 125	NPS 5	X	o	-	-

Symbols key

Symbol	Description
X	Standard
o	Option

20) Type RF (Raised Face)

Interchangeability of Etaprime L and Etaprime B pump components
Components featuring the same number in a column are interchangeable.

Interchangeability of Etaprime L and Etaprime B pump components and interchangeability of components among each other

Size	Shaft unit	Description									
		Volute casing	Casing cover	Shaft	Impeller	Radial ball bearing	Radial ball bearing	Bearing housing	Mechanical seal	Shaft sleeve	
		Part No.									
		102	161	210	230	321.01	321.02	350	433.01	523	
025-025-100	17	○*	✗	1	○*	1	2	1	1*	✗	
032-032-120	17	○*	✗	1	○*	1	2	1	1*	✗	
040-040-110	17	○*	✗	1	○*	1	2	1	1*	✗	
040-040-140	25	○*	○*	2	○*	✗	3	✗	2*	1*	
050-050-130	25	○*	○*	2	○*	✗	3	✗	2*	1*	
050-050-160	25	○*	1*	2	○*	✗	3	✗	2*	1*	
065-065-150	25	○*	1*	2	○*	✗	3	✗	2*	1*	
065-065-180	35	○*	○*	3	○*	✗	4	✗	3*	2*	
080-080-170	35	○*	○*	3	○*	✗	4	✗	3*	2*	
080-080-190	35	○*	○*	3	○*	✗	4	✗	3*	2*	
080-080-200	35	○*	○*	3	○*	✗	4	✗	3*	2*	
100-100-240.1	35	1*	○*	3	○*	✗	4	✗	3*	2*	
100-100-240 ²¹⁾	35	1	○	3	○	✗	4	✗	3	2	
125-125-260 ²¹⁾	35	○	○	3	○	✗	4	✗	3	2	

Symbols key

Symbol	Description
*	Component interchangeable with Etaprime B
○	Components differ
✗	Component not fitted

Scope of supply

Depending on the model, the following items are included in the scope of supply:

- Pump
- Electric motor
- Flexible coupling with or without spacer
- Coupling guard
- Channel section steel or folded steel plate

Optional:

- Cast baseplate to ISO 3661

 21) Not available as Etaprime B

General assembly drawings with list of components

Etaprime G and C, threaded connection, with bearing housing (SU 17)

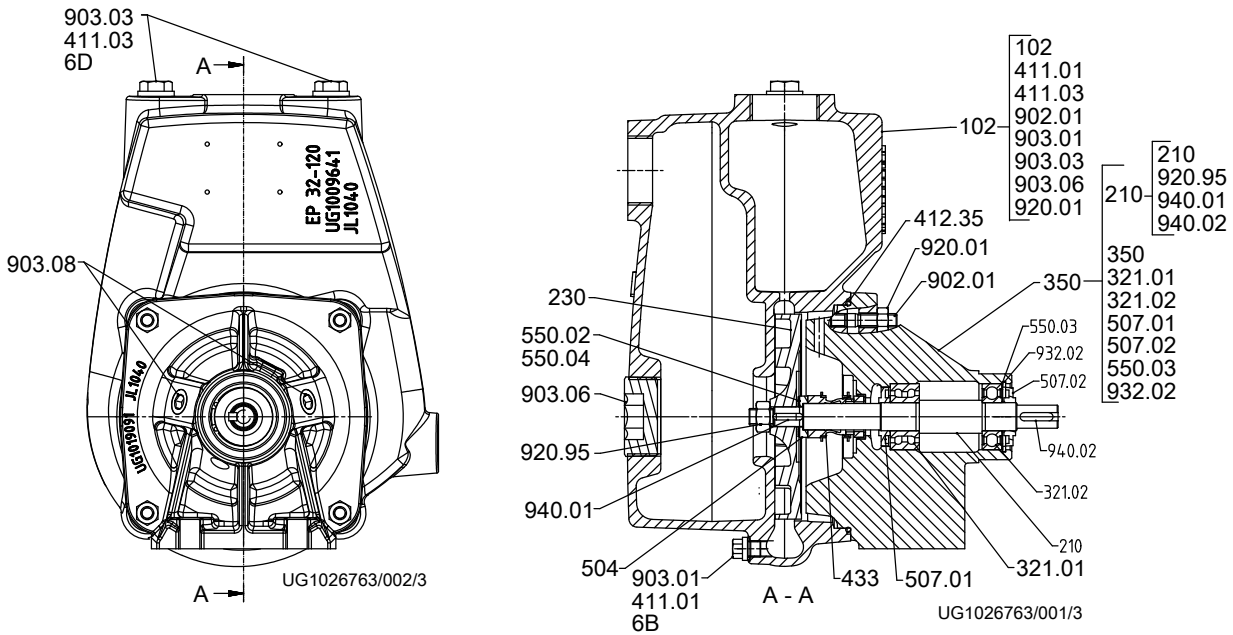

Fig. 8: Model with single mechanical seal
[Supplied in packaging units only

List of components

Part No.	Description	Part No.	Description
102	Volute casing	504	Spacer ring
210	Shaft	507.01/.02	Thrower
230	Impeller	550.02/.03/.04	Disc
321.01/.02	Radial ball bearing	902.01	Stud
350	Bearing housing	903.01/.03/.06/.08	Screw plug
411.01/.03	Joint ring	920.01/.95	Nut
412.35	O-ring	932.02	Circlip
433	Mechanical seal	940.01/.02	Key

Connections

Part No.	Description	Part No.	Description
6B	Fluid drain	6D	Fluid priming and venting

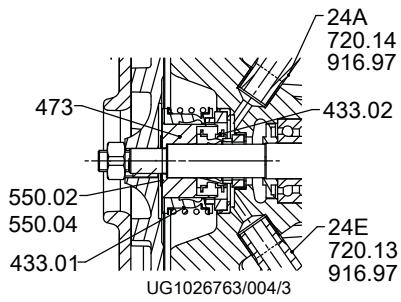

Fig. 9: Model with double mechanical seal in tandem arrangement (SU 17)

List of components

Part No.	Description	Part No.	Description
433.01/02	Mechanical seal	720.13/14	Barrel nipple
473	Primary ring carrier	916.97	Plug
550.02/04	Disc		

List of components

Part No.	Description	Part No.	Description
24A	Quench liquid outlet	24E	Quench liquid inlet

Etaprime G and C, flanged connection, with bearing bracket/grease lubrication (SU 25 and SU 35)

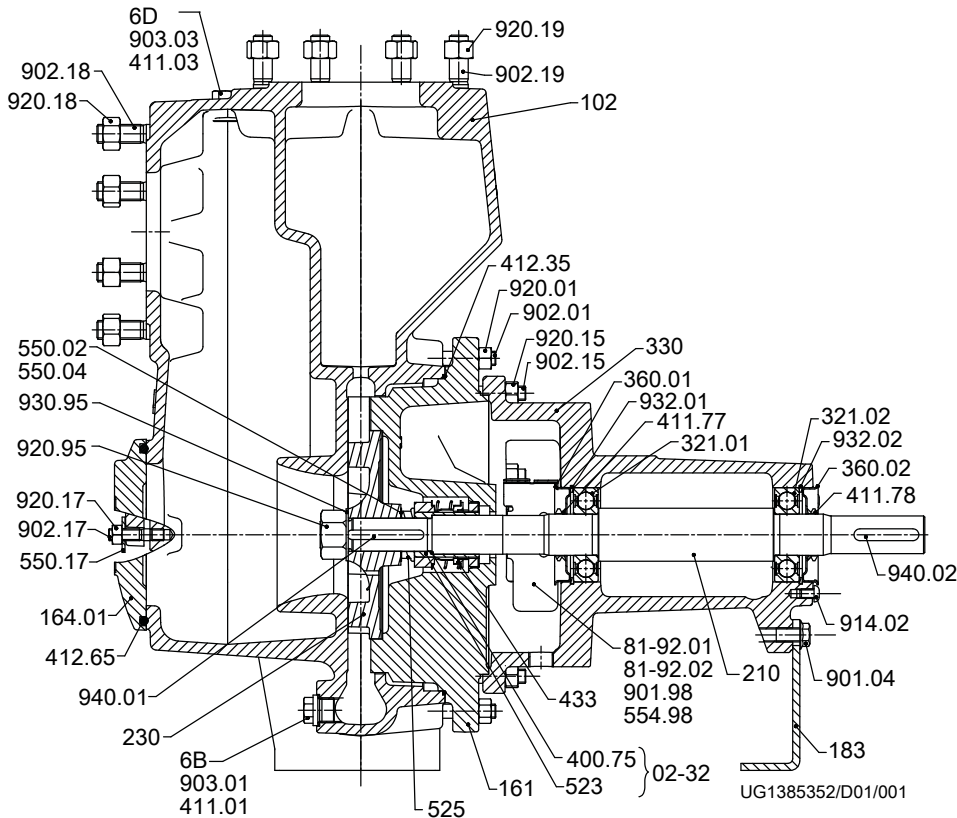

Fig. 10: Model with single mechanical seal

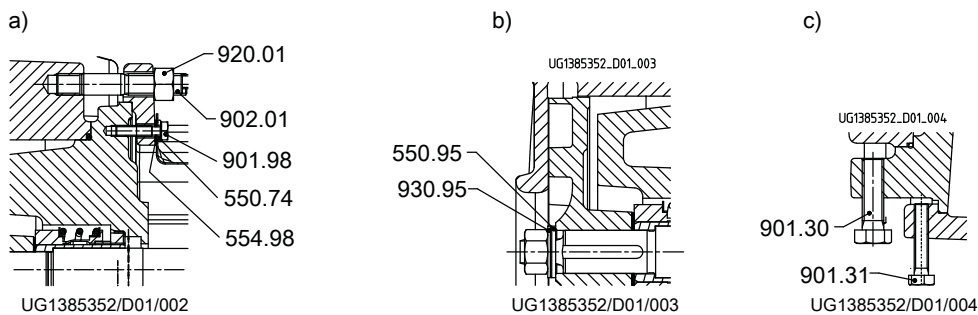

Fig. 11: a) Clamped casing cover, b) impeller fastening elements for shaft unit 25, c) Position of forcing screws

List of components

Part No.	Description	Part No.	Description
102	Volute casing	525 ²²⁾	Spacer sleeve
161	Casing cover	550.02/.04/.17/.74	Disc
164.01	Inspection cover	550.95 ²³⁾	Disc
183	Support foot	554.98	Lock washer
210	Shaft	81-92.01/.02	Cover plate
230	Impeller	901.04/.30/.31/.98	Hexagon head bolt
321.01/.02	Radial ball bearing	902.01/.15/.17/.18/.19	Stud
330	Bearing bracket	903.01/.03	Screw plug
360.01/.02	Bearing cover	914.02	Pan head screw
400.75	Gasket	920.01/.05/.15/.17/.18/.19/.95	Nut
411.01/.03/.77/.78	Joint ring	930.95	Safety device

22) For SU 35 only; shaft unit see data sheet.

23) For SU 25 only; shaft unit see data sheet.

Part No.	Description	Part No.	Description
412.35/.65	O-ring	932.01/.02	Circlip
433	Mechanical seal	940.01/.02	Key
523	Shaft sleeve		

Connections

Part No.	Description	Part No.	Description
6B	Fluid drain	6D	Fluid priming and venting

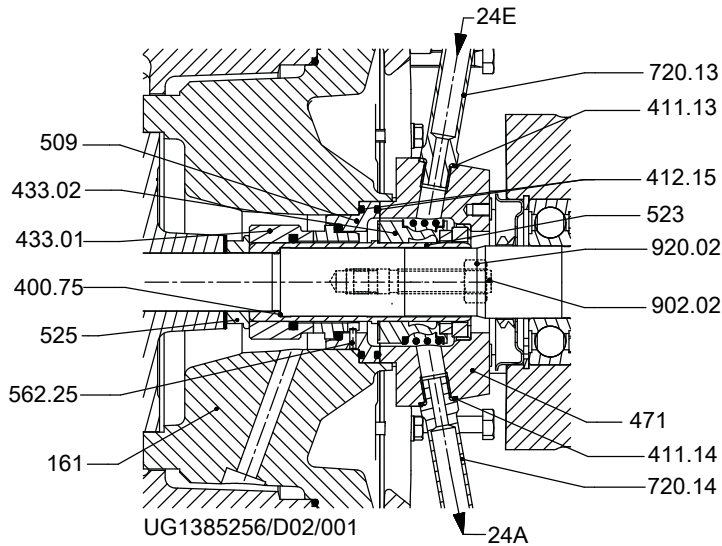
Fig. 12: Model with double mechanical seal in tandem arrangement (SU 25/35)
List of components

Part No.	Description	Part No.	Description
161	Casing cover	523	Shaft sleeve
400.75	Gasket	525	Spacer sleeve
412.15	O-ring	562.25	Parallel pin
411.13/.14	Joint ring	720.13/.14	Spacer
433.01/.02	Mechanical seal	902.02	Stud
471	Seal cover	920.02	Hexagon nut
509	Intermediate ring		

Connections

Part No.	Description	Part No.	Description
24A	Quench liquid outlet	24E	Quench liquid inlet

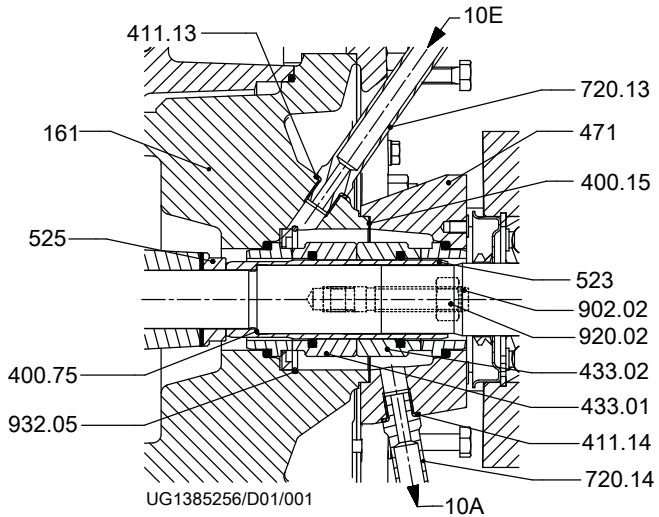

Fig. 13: Model with double mechanical seal in back-to-back arrangement (SU 25/35)

List of components

Part No.	Description	Part No.	Description
161	Casing cover	525 ²⁴⁾	Spacer sleeve
400.15 ²⁵⁾ /75	Gasket	720.13/.14	Spacer
411.13/.14	Joint ring	902.02	Stud
433.01/.02	Mechanical seal	920.02	Hexagon nut
471	Seal cover	932.05	Circlip
523	Shaft sleeve		

Connections

Part No.	Description	Part No.	Description
10A	Barrier fluid outlet	10E	Barrier fluid inlet

24) For SU 35 only; shaft unit see data sheet.
25) For shaft unit 25: joint ring 411.15 (shaft unit see data sheet)

Etaprime G and C, flanged connection, with bearing bracket/oil lubrication (SU 25 and SU 35)

Design of pump and mechanical seal as described on (⇒ Page 27)

Difference: oil-lubricated bearing bracket instead of grease-lubricated bearing bracket.

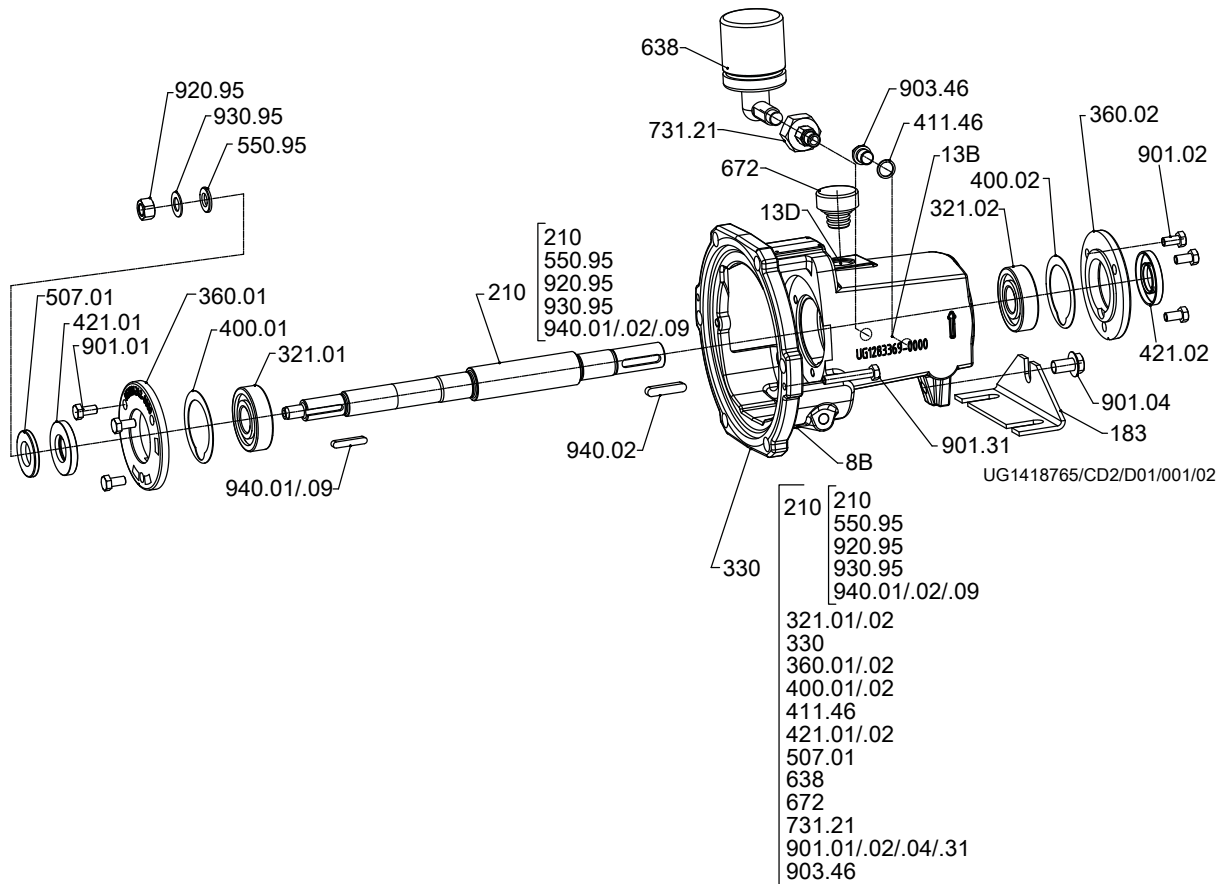

Fig. 14: Model with oil lubrication and constant level oiler

[Supplied in packaging units only

List of components²⁶⁾

Part No.	Description	Part No.	Description
183	Support foot	550.95 ²⁷⁾	Disc
210	Shaft	638	Constant level oiler
330	Bearing bracket	672	Vent
321.01/.02	Deep groove ball bearing	731.21	Pipe union
360.01/.02	Bearing cover	901.01/.02/.04/.31	Hexagon head bolt
400.01/.02	Gasket	903.46	Screw plug
411.46	Joint ring	920.95	Hexagon nut
421.01/.02	Lip seal	930.95	Spring washer
507.01	Thrower	940.01/.02/.09 ²⁸⁾	Key

Connections

Part No.	Description	Part No.	Description
8B	Leakage drain	13D	Oil filling and venting
13B	Oil drain		

26) Some individual components might not be applicable, depending on the size and shaft material.

27) For shaft unit 25 only

28) For shaft units 55 and 60 only



KSB Aktiengesellschaft
Johann-Klein-Straße 9 • 67227 Frankenthal (Germany)
Tel. +49 6233 86-0
www.ksb.com